

2020

WSA Swather

For use with the WR9900 Windrower

Operator Manual

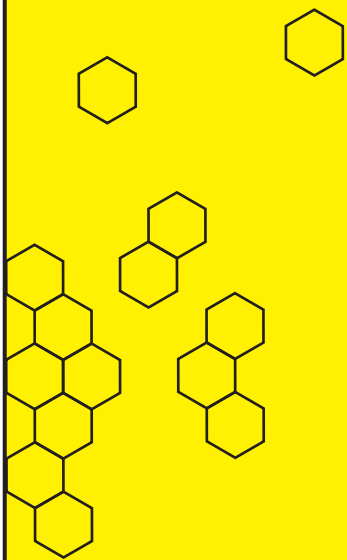

Honey Bee[®]

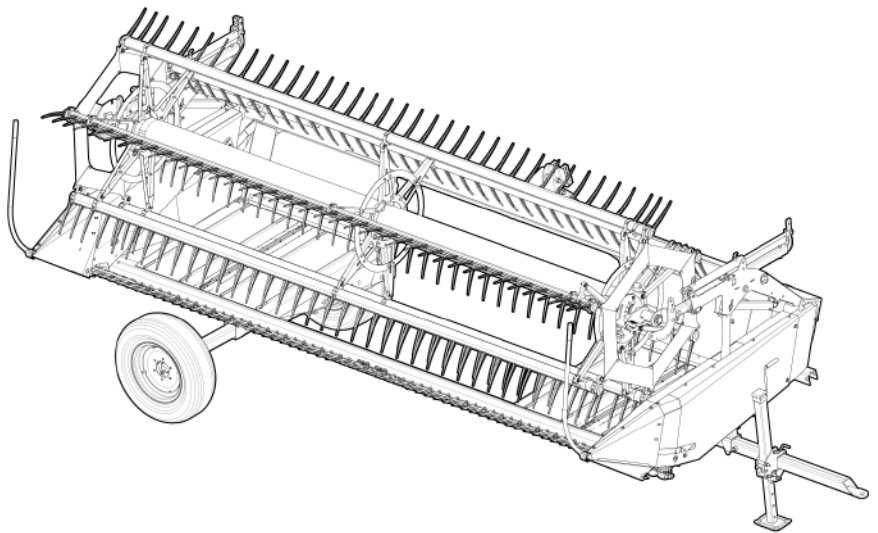

Document Revision History			
Revision	Author	Date	Description
1.0	AD & BL	06/03/2020	Document published
1.1	AD	13/03/2020	Fixed chain lug illustration, corrected electrical schematic, added note mentioning reel serial number.

WSA Swather Pre Delivery Inspection

TO THE DEALER: *This form must be completed and returned to Honey Bee Manufacturing Ltd. along with the Warranty Registration Form. (please print)*

Model: _____ Serial #: _____
Check Completed By: _____ Signature: _____
Dealer Name: _____ Date: _____

As soon as you receive this machine, inspect it thoroughly to be certain that it is in good order and complete. Finish a pre-delivery inspection, paying special attention to the steps listed below, prior to delivery to the customer. Indicate with a tick mark in the left-hand column when correct/complete.

Pre Run-in Checks:

- _____ Crop dividers and crop divider pipe/snub nose installed.
- _____ Quick couplers match windrower.
- _____ Reel tie-down removed.
- _____ Knife drive hold down bolts torqued to 120 ft-lb (163 Nm).
- _____ Knife head block torqued to 53 ft-lb to 73 ft-lb (72 Nm to 99 Nm).
- _____ Knife head bearing bolt torqued to 59 ft-lb (80 Nm).
- _____ Reel centered in swather left to right.
- _____ Reel fingers clear cutterbar by approximately 2" across length of the knife.
- _____ Safety and warning decals affixed securely and clearly readable.
- _____ Safety guards and shields installed and secure.
- _____ Swather lubricated.
- _____ Optional equipment, as per sales order, is installed and operates correctly.

Mounting Checks:

- _____ Hydraulic oil pressures and flow rates are set.
- _____ Electrical systems working properly.
- _____ Hydraulic plumbing is leak-free.
- _____ Drapers on all decks track evenly with adequate clearances.
- _____ Drapers are tensioned. DO NOT OVERTIGHTEN
- _____ If draper deck shift is installed ensure all stops are properly set.

Pre Transport Checks:

- _____ Hitch and axle attached and secure.
- _____ Reel lowered in the full-aft position, and tied down.
- _____ Wheel bolts torqued to 120 ft-lb (163 Nm).
- _____ Tire pressures @ 65 psi (449 KPa)
- _____ All lock pins in place and securely fastened.
- _____ All fasteners and parts secure.
- _____ Wiring, hydraulic hoses, and fittings/connections secure.
- _____ Reflectors and SMV sign in place and clean.
- _____ Warning and clearance lights installed and operational.

This Page Intentionally Left Blank

 **IMPORTANT!**

This manual covers the WSA swather ONLY.

The swather is to be used with the WR9900 windrower ONLY.

Review the sections of this manual regarding adjustments, settings, leveling, and table height before attempting to operate this swather.

Without proper adjustment, damage to the swather may occur.

 **IMPORTANT!****Please wash this equipment after transporting!**

Honey Bee Manufacturing will not be responsible for any paint deterioration resulting from salt or harsh chemical corrosion if this equipment is not properly washed after transport. Use a mild soap solution, then rinse thoroughly.

If this equipment is stored near salted roadways through the winter months, it should be cleaned each spring.

 **IMPORTANT!****If reading this as a digital document:**

Please be aware that the table of contents and cross references within this document can be clicked to bring you directly to the contents they reference.

On most software, you can press CTRL+F to bring up a search box that allows you to find specific words or terms within the document.

Original Instructions

© 2020 Honey Bee Manufacturing Ltd. - All Rights Reserved

Patents: www.honeybee.ca/patents.php

This Page Intentionally Left Blank

Purchase Information

Dealers Name: _____

Address: _____

Phone: () _____

Purchase Date: _____

Model: _____

Serial Number: _____

Delivery Date: _____

Modification Record	
Date	Modification

Honey Bee Manufacturing Limited is continually striving to improve its products. We reserve the right to make improvements or changes when it becomes practical and possible to do so, without incurring any obligation to make changes or additions to the equipment sold previously.

Hydraulic Readings

Use this page to record any specific hydraulics readings and/or settings done upon initial dealer inspection. See Installation and Hydraulics sections of this manual for reference.

Knife Drive Pressure Gauge (when checking relief pressure): _____ PSI

Knife Drive speed (at normal working engine RPM): _____ RPM

Draper Drive pressure gauge (at normal working engine RPM): _____ PSI

Knife Drive pressure gauge (at normal working engine RPM): _____ PSI

 Other Settings: _____

This Page Intentionally Left Blank

Table of Contents

1 - Introduction	13
1.1 - Directions.....	13
1.2 - Warranty.....	13
1.3 - Specifications.....	14
1.4 - Swather Identification Number.....	14
2 - Safety	15
2.1 - Recognize Safety Information.....	15
2.2 - Understand Signal Words.....	15
2.3 - Read and Understand Instructions and Warnings.....	15
2.4 - Protective Clothing.....	15
2.5 - In Case of Emergency.....	15
2.6 - High Pressure Spray.....	16
2.7 - Store the Swather Safely.....	16
2.8 - Safety Around Moving Parts.....	16
2.9 - High-Pressure Hydraulics.....	16
2.10 - Practice Safe Maintenance.....	16
2.11 - Transporting the Swather.....	17
2.12 - Before Transport Checklist.....	17
2.13 - During Transport Checks.....	17
2.14 - In-Field Checks.....	17
2.15 - Using Correct Torque Values.....	17
2.16 - Fire Safety.....	17
2.17 - Safety Feature & Decal Locations.....	18
3 - Equipment Overview	21
4 - Before First Use and Pre-Season Inspection	23
4.1 - Swather Inspection.....	23
5 - Installation	25
5.1 - Preparation - Mechanical.....	25
5.2 - Crop Divider Installation.....	25
5.3 - Setting Swather Table Width.....	26
5.4 - Mounting the Swather to the Windrower.....	26
5.5 - Store the Transport Axle.....	28
5.6 - Transport Hitch - Convert to Field Operation (for 21ft+ Tables).....	30
5.6.1 - Transport Hitch - Optional Removal (for 21ft+ Tables).....	30
5.7 - Transport Hitch - Convert to Field Operation (for 15ft Tables).....	31
5.8 - Connect Electrical and Hydraulic Systems.....	31
5.9 - Mounting Checklist.....	32
5.10 - System Checks.....	32
5.11 - Hydraulics, Electric and Mechanical Checklist.....	32
6 - Hydraulics	33
6.1 - Theory of Operation.....	33
6.2 - Manifold Block Cartridge Locations.....	33
6.3 - Hydraulic Operating Pressures.....	34
6.4 - Draper and Reel Speed Controls.....	34
6.5 - Return Line Filter.....	35
6.6 - 15ft WSA Hydraulic Schematic.....	36

7 - Drapers	37
7.1 - Lining Up the Idler Roller	37
7.2 - Draper Installation	37
7.3 - Tensioning	38
7.3.1 - Spring Tension Indicator	38
7.4 - Tracking	39
7.4.1 - Idler Roller Tracking Adjustment	39
7.4.2 - Drive Roller Tracking Adjustment	39
7.5 - Draper Speed	40
7.6 - Draper Splicing	40
7.7 - Idler Roller Removal	41
7.8 - Drive Roller Removal	42
7.9 - Removing Draper Motor	42
7.10 - Replace Bearings on Drive Roller	43
7.11 - Replace Bearings on Idler Rollers	43
7.12 - Installing Draper Motor	44
7.13 - Draper Deck Maintenance:	44
8 - Reel	45
8.1 - Set Reel Safety Stops	45
8.2 - Reel Drive	45
8.3 - Reel Speed Adjustment	46
8.4 - Reel Position	46
8.4.1 - Hydraulic Fore & Aft	46
8.5 - Reel Arm Leveling and Height Adjustment	47
8.6 - Reel Centering	48
8.7 - Honey Bee Reel Tine Pitch Adjustment	48
8.8 - Reel Finger Replacement	49
8.9 - Rephasing Reel Cylinders	49
8.10 - Reel Speed Sensor Adjustment	49
8.11 - Check Points Before Operating the Reel:	50
9 - Swather Transport & Storage	51
9.1 - Read before Transporting	51
9.2 - Transporting on Windrower	51
9.3 - Transporting on Transport Axle	52
9.4 - End of Season Storage	54
10 - Regular Service & Adjustment	55
10.1 - Fasteners	55
10.2 - Permanent Bushings	55
10.3 - Lubrication	56
10.3.1 - Grease	56
10.3.2 - Alternative and Synthetic Lubricants	56
10.3.3 - Lubricant Storage	56
10.3.4 - Mixing of Lubricants	56
10.3.5 - Lubrication Interval Chart	57
10.4 - Recommended Torque Values (ft-lb)	58
11 - Troubleshooting	59
11.1 - Reel	59
11.2 - Drapers	59
11.3 - Cutting Platform	60
11.4 - Cutting Platform (continued)	60
11.4.1 - Miscellaneous	61

11.5 - Electrical Schematic.....	62
11.5.1 - Electrical Overview.....	62
11.5.2 - Main Harness.....	63
12 - Support.....	64

This Page Intentionally Left Blank

1 - Introduction

All information, illustrations and specifications in this manual are based on the latest information available at the time of publication. The right is reserved to make changes at any time without notice.

This manual should be considered a permanent part of your swather and should remain with the machine when you sell it.

Measurements in this manual are given in metric as well as imperial unit equivalents. Use only correct replacement parts and fasteners. Metric and inch fasteners require a specific metric or inch wrench.

All names given in this document for equipment components are those in use at the time of design.

Please write down your equipment serial numbers to help in tracing the swather should it be stolen. Your dealer also needs these numbers when you order parts. File the identification numbers in a secure place away from the swather.

1.1 - Directions

Right and left hand sides are determined by facing in the direction the implement will travel when going forward.

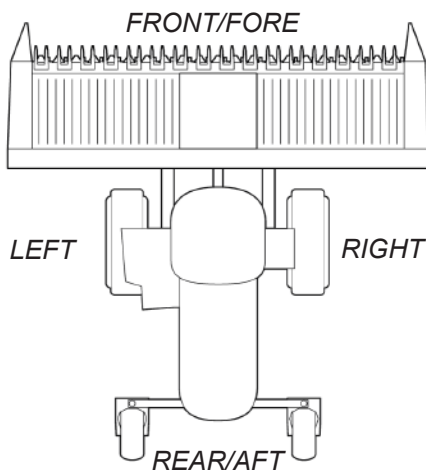

Fig. 1 - Reference directions

1.2 - Warranty

The warranty is provided as part of Honey Bee's support program for customers who operate and maintain their equipment as described in this manual.

Honey Bee Manufacturing Ltd. (Honey Bee) warrants your new swather to be free of defects in material and workmanship, under normal use and service. Obligations under this warranty shall extend for a period of 1 year (12 months) following the date of first use to the original purchaser and shall be limited to, at the option of Honey Bee, replacement or repair of any parts found, upon inspection by Honey Bee, to be defective.

Warranty Claims

The purchaser claiming under this warranty shall report a warranty claim to his Authorized Dealer. The dealer shall complete the claim, on the prescribed form online, for inspection by an authorized company representative. Warranty claims must be submitted online within 60 days of warranty expiration on the Honey Bee Manufacturing Ltd Claim Form (CFI).

Limitations of Liability

This warranty is expressly in lieu of all other warranties expressed or implied and all other obligations or liabilities on our part of any kind or character, including liabilities for alleged representations or negligence. We neither assume nor authorize any person to assume, on our behalf, any liability in connection with the subsequent sale of the swather.

This warranty shall not apply to any swather which has been altered outside the factory in a way that Honey Bee judges to affect its operation or reliability, or which has been subject to misuse, neglect, or accident.

Operator's Manual

The purchaser acknowledges having received training in the safe operation of the swather and that Honey Bee does not assume any liability resulting from the operation of the swather in any manner other than described in this manual.

1.3 - Specifications

Model	WSA 9900 15ft
Cutting Width	15 feet (4.57 meters)
Total Width (including transport draw bar)	19 4/5 feet (6 meters)
Weight	3465 lbs (1572 kg)
Cutting System	Hydraulically driven knife drive.
Drapers	Hydraulically driven with simple to use tensioning system.
Reel	Hydraulically driven, with multiple crop settings and finger spacing options.
Transport	Built-in transport cart with detachable draw bar and wheels.
Record your equipment serial numbers below for reference in the event of service or theft.	
Swather Serial Number:	
Reel Serial Number	
These specifications are subject to change without notice or obligation.	

1.4 - Swather Identification Number

The Swather serial number plate is located directly on top of the hydraulic bulkhead as shown below. The letters and numbers stamped on the plate identify the swather. Please have this serial number on hand when ordering replacement parts. If ever stolen, the serial number is needed for law enforcement to trace.

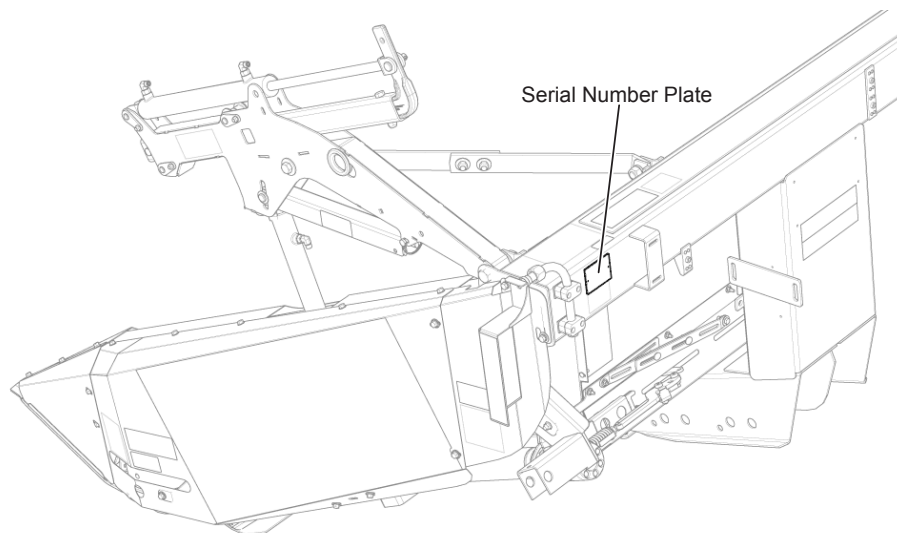

Fig. 2 - Serial number plate location

NOTE:
The reel has its own serial number, located on a decal at the end of the reel tube.

2 - Safety

2.1 - Recognize Safety Information



This is a safety-alert symbol. When you see this symbol, be alert to the potential for personal injury. Follow recommended precautions and safe operating practices.

2.2 - Understand Signal Words

The following are safety terms used around the equipment and throughout this manual. Please read and understand their descriptions.

DANGER!

Indicates an imminently hazardous situation that, if not avoided, will result in death or serious injury. This signal word is to be limited to the most extreme situations.

WARNING!

Indicates a potentially hazardous situation that, if not avoided, could result in death or serious injury, and includes hazards that are exposed when guards are removed. It may also be used to alert against unsafe practices.

CAUTION!

Indicates a potentially hazardous situation that, if not avoided, may result in minor or moderate injury. It may also be used to alert against unsafe practices.

IMPORTANT!

Warns of potential damage to the swather if proper procedures are not followed.

NOTE:

Notifies you of important information to which you should pay attention.

2.3 - Read and Understand Instructions and Warnings

Read and understand all warnings and safety information contained within this manual and on the safety signs located on your equipment. These should be reviewed by each operator at least once a year per OSHA regulations 1928.57.

You may find additional safety information on aftermarket optional equipment that may not be included in this manual.

Only allow trained individuals to operate the swather. Failure to comply can result in injury and/or equipment damage.

Unauthorized equipment modifications can cause injury or equipment failure that is not covered under warranty.

2.4 - Protective Clothing

WARNING!

When working around running equipment, secure all loose items such as long hair, jewelry, or loose clothing are secured so they do not contact moving parts. Failure to do so will result in injury or death.

Wear hearing protection to protect against hearing damage.

Operating equipment safely requires your full attention, do not wear headphones while operating the swather.

2.5 - In Case of Emergency

Keep a first aid kit and fire extinguisher with your swather at all times. Keep phone numbers for emergency services near your telephone.

2.6 - High Pressure Spray

IMPORTANT!

Avoid spraying yourself, electronics or hydraulic connections with a pressure sprayer.

2.7 - Store the Swather Safely

WARNING!

Ensure your swather and all attachments are secured when not in use. Keep bystanders away from equipment and storage area. Failure to comply can result in injury or death.

2.8 - Safety Around Moving Parts

DANGER!

Never attempt to service your equipment while in operation. Always shut off the windrower and wait for all moving parts to come to a complete stop before approaching the swather.

Keep guards and shields in place at all times. Ensure that they are serviceable and installed correctly.

Cutterbar, reel, and drapers cannot be completely shielded due to their function. Stay clear of these moving elements during operation.

2.9 - High-Pressure Hydraulics

DANGER!

High pressure hydraulic leaks can penetrate the skin causing serious injury. Always relieve pressure before disconnecting hydraulic lines and tighten all connections before applying pressure.

Hydraulic leaks can be extremely small and difficult to see. Search for leaks by holding up a piece of cardboard in the suspected area. Protect hands and body from high-pressure fluids.

If an accident occurs, see a doctor immediately. Any fluid injected into the skin must be surgically removed within a few hours or gangrene may result. Doctors unfamiliar with this type of injury should reference a knowledgeable medical source.

2.10 - Practice Safe Maintenance

WARNING!

Before attempting to service your equipment, ensure that you fully understand any procedure that you are about to attempt.

Ensure all equipment is secured against sudden drops.

Keep the work area clean and dry.

Keep all parts in good condition and properly installed. Fix damage immediately. Replace worn or broken parts. Remove buildup of grease, oil, or debris.

If welding on the swather, first disconnect battery ground cable (-). before making adjustments to electrical systems or welding on the swather.

The swather must be lowered to the ground before servicing. If the work requires that the swather or reel be lifted, provide secure support. If left in a raised position, hydraulically supported devices can settle or drop suddenly.

Do not support the swather on cinder blocks, hollow tiles, or props that may crumble under continuous load. Do not work under a swather that is supported only by a jack.

Do not attempt to clean drapers with flammable cleaning solvents.

2.11 - Transporting the Swather



IMPORTANT!

When transporting the swather, frequently check for traffic from the rear, especially in turns. Always use headlights, flashing warning lights, and turn signals (when turning) day and night. Follow local regulations for equipment lighting and marking. Keep lighting and marking visible, clean, and in good working order, replace if necessary.

Whenever possible avoid transporting the swather on public roadways with swather attached to the windrower.

If windrower must be transported with swather attached, ensure all warning lights are operating, and reflective material is clean and visible.

Completely retract and lower the reel before transporting.

Use of a spotter or pilot vehicle is recommended on busy, narrow or hilly roads and when crossing bridges.

Drive at a speed safe for conditions.

Do not exceed 20 mph (32 kph) when transporting the swather on the optional transport package.

2.12 - Before Transport Checklist

Do a complete walk-around and ensure everything is secure.

Check:

- All reel mounting and reel drive bolts to be sure no bolts/nuts are loose;
- Wheel bolts to make sure they are tight;
- Transport tire pressure - recommended pressure is 65 psi (448 kPa).
- Spindle and hitch lock pins - ensure they are in place and securely fastened.
- Inspect all hoses. Ensure they are secured so they will not pinch or drag during transport.
- Ensure hitch tongue and safety chain are fastened to the swather and to the transporting vehicle.

2.13 - During Transport Checks

Stop after the first 5 to 10 kilometers (2 to 6 miles) and check to make sure the wheel bolts are tight (The bolts should be torqued to 120 ft/lbs (163 Nm)) and ensure the wheel hubs are not hot. Make periodic checks every 50 to 60 km (31 -37 miles) if towing the swather long distances.

Check the hitch bolt and safety chain periodically to make sure they are secure.

2.14 - In-Field Checks

The First Time Setup and Operation section of your owner's manual covers the adjustments which may be required on your Grain Belt swather. Read this section carefully before using your Grain Belt swather. Make the necessary adjustments before operating your swather, and check these adjustments periodically as required.

2.15 - Using Correct Torque Values



IMPORTANT!

It is extremely important that you use the correct torque values when servicing your swather. Failure to follow the torque recommendations on page 58 can result in equipment damage.

2.16 - Fire Safety



WARNING!

Inspect the swather for material buildup on a daily basis. Build up of chaff and crop debris near moving parts is a fire hazard. Check and clean these areas frequently. Before inspection or service, shut off engine, engage the parking break, remove the key and wait for all moving parts to come to a stop.

Keep a fire extinguisher with your equipment at all times and ensure the operator is educated in its operation.

2.17 - Safety Feature & Decal Locations

Please take a moment to walk around your equipment and familiarize yourself with the safety decals and features on your equipment. Refer to the figure below and the decal list on the following pages for assistance.

Please ensure that you fully understand all safety warnings and instruction before operating this equipment.

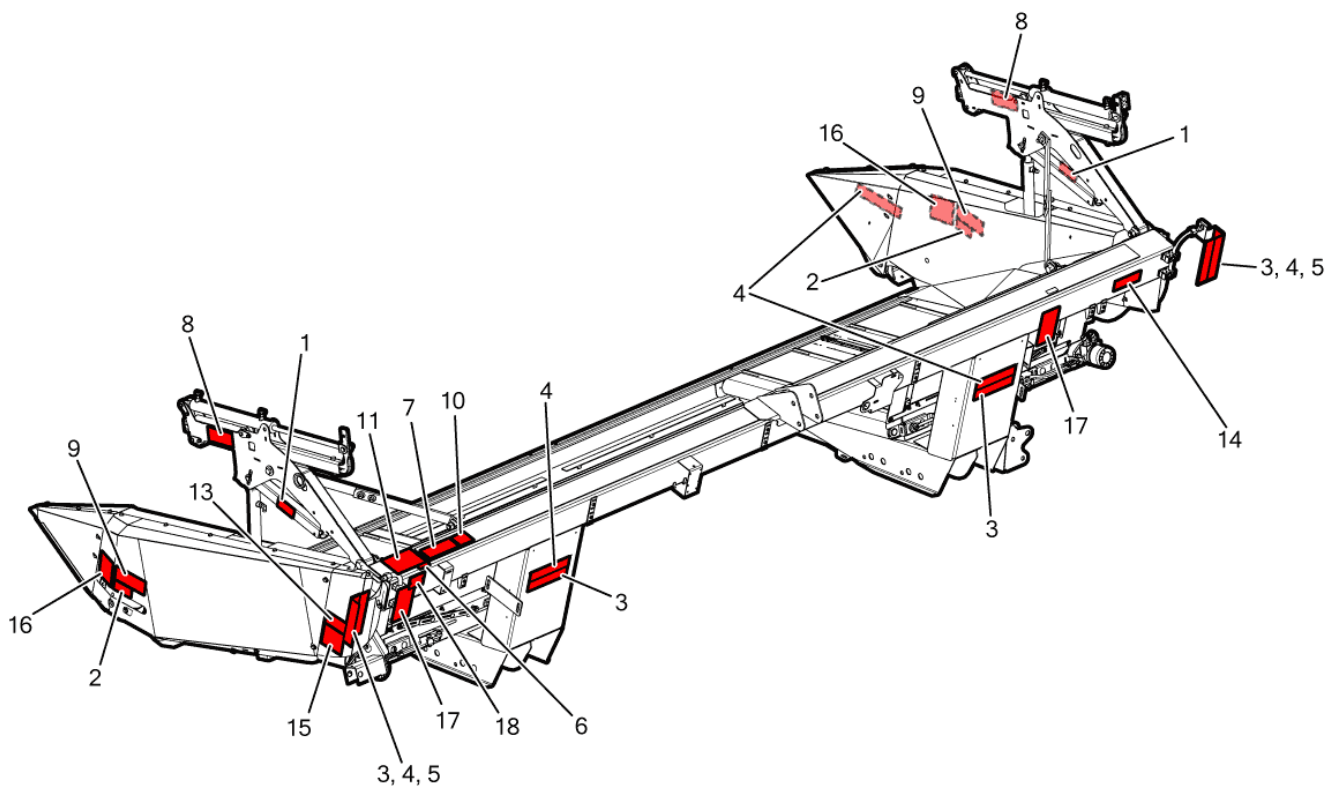

Fig. 3 - Decal Locations

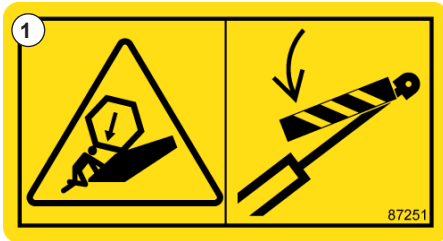

Fig. 4 - Reel drop warning



Fig. 5 - Knife shield warning



Fig. 6 - Red/Orange reflector



Fig. 7 - Red reflector



Fig. 8 - Yellow reflector

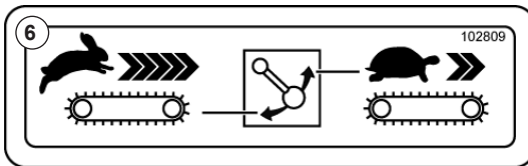

Fig. 9 - Draper speed label



Fig. 10 - Hydraulic spray warning



Fig. 11 - Rotating parts warning



Fig. 12 - Sharp knife section warning

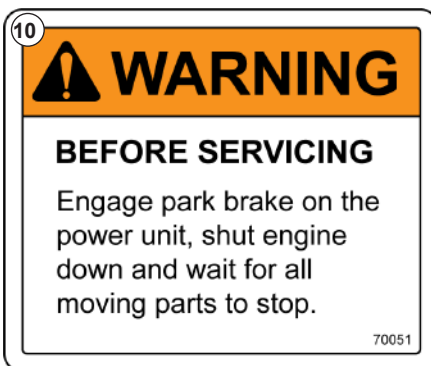

Fig. 13 - Servicing Warning

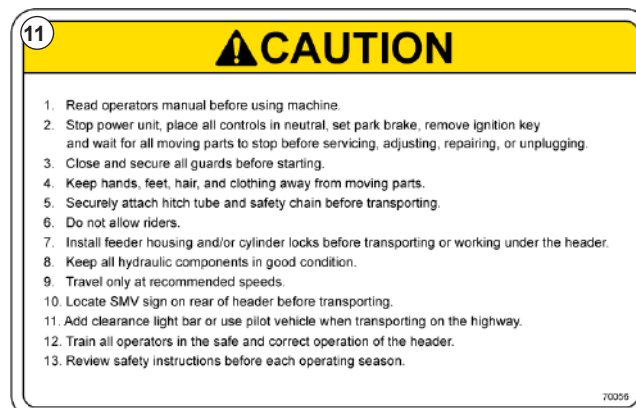

Fig. 14 - Caution - read manual



Fig. 15 - Caution - Maximum safe speed

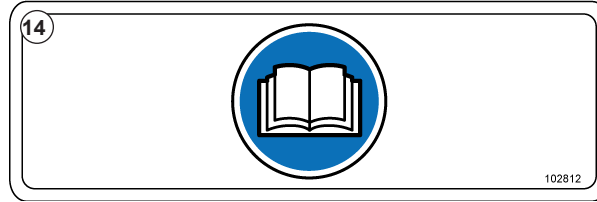

Fig. 16 - Operator manual label

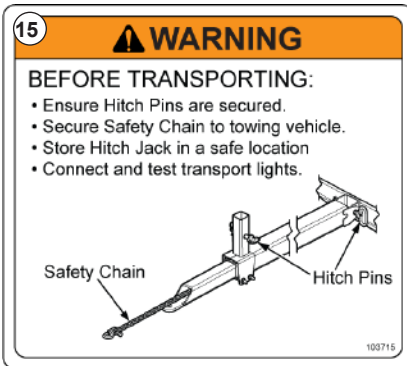

Fig. 17 - Transport hitch warning

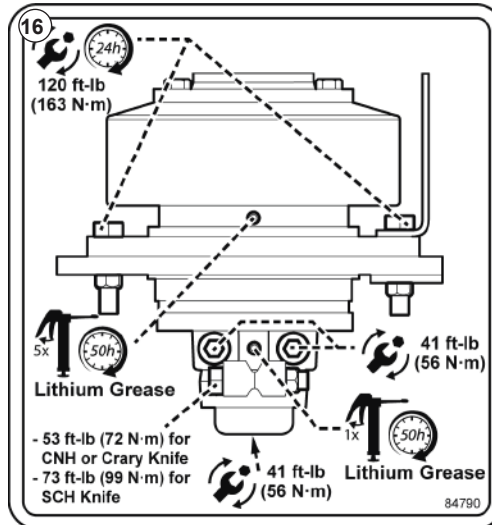

Fig. 18 - Knife drive servicing decal

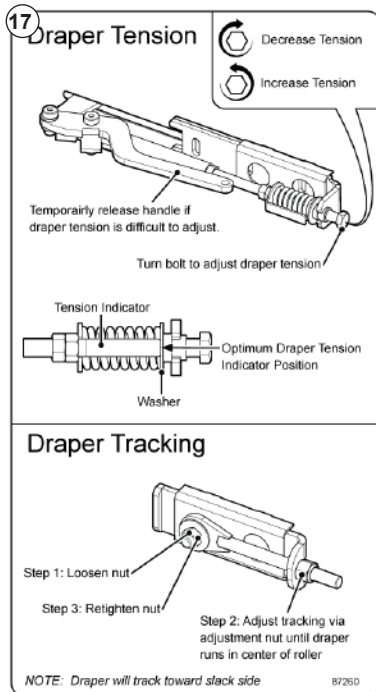

Fig. 19 - Draper tension instructions

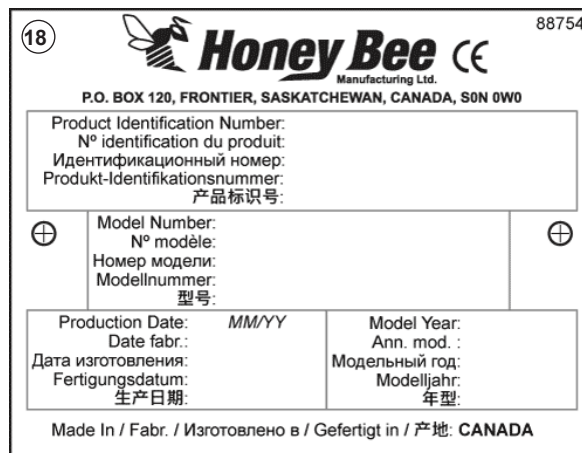

Fig. 20 - Serial number plate

3 - Equipment Overview

Please take a moment to familiarize yourself with the WSA Swather, its components and modes of operation.

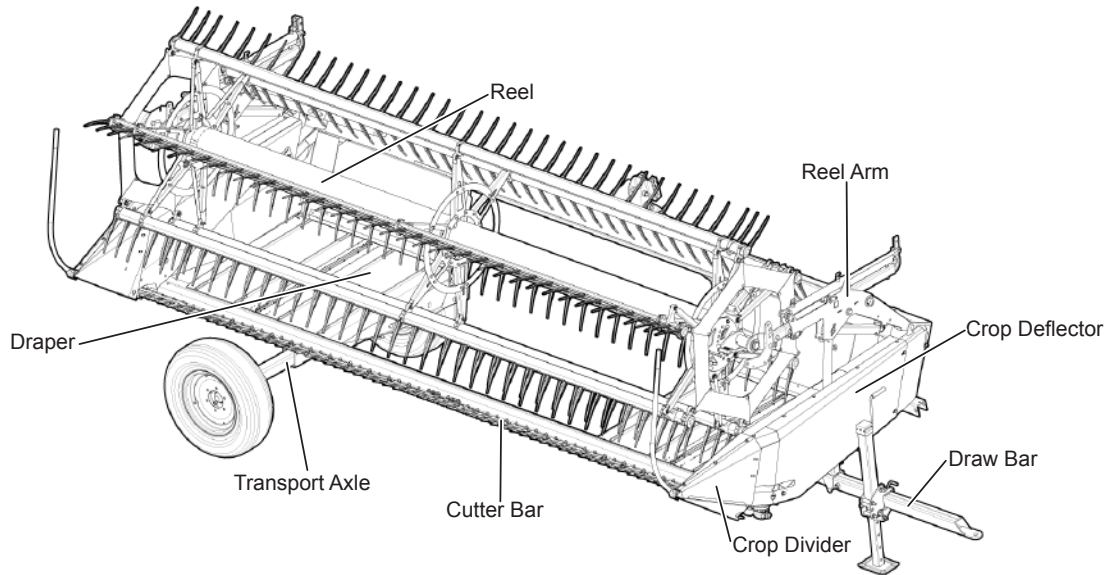

Fig. 21 - Swather Overview

This Page Intentionally Left Blank

4 - Before First Use and Pre-Season Inspection

4.1 - Swather Inspection

Dirt & Material Build-up

Inspect the swather for dirt, material buildup and obstructions then clean/clear as necessary (inside drapers, under side shields, around drive belts, feeder house etc.).

Cutting System

Inspect the cutting system for signs of damage, wear or material buildup.

Check for broken knife sections, guards & hold-downs.

Drapers

Check the draper belts for damage or uneven wear. Replace when required.

Ensure the draper belts are properly tensioned and that they are tracking properly. See section 7.3 on page 38 for details.

Safety Shields

Inspect the swather and ensure all protective shields are in place. Replace all damaged or missing shields. Inspect the shields for missing/loose fittings.

Multicoupler

Thoroughly inspect the connection faces on the swather and the power unit sides of the hydraulic multicoupler. Ensure the o-rings are in place and clean all debris from the fittings.

Inspect the hydraulic hoses and replace/repair as needed.

Lubrication

Apply grease where needed as outlined in section 10.3 on page 56 section of this manual.

Take Note

...of items that require attention after the swather is connected to the windrower as outlined in the windrower operator's manual.

Checklist

- Inspect the swather for dirt, buildup and obstructions then clean as necessary (inside drapers, under side shields, feeder house etc.).
- Inspect the cutting system for signs of damage, wear or material buildup.
- Check the draper belts for damage or uneven wear. Replace when required.
- Ensure the draper belts are properly tensioned and that they are tracking properly. See section 7.3 on page 38.
- Ensure the crop dividers are properly installed & free from material buildup. See Fig. 23 on page 25
- Ensure all protective shields are in place. Replace all damaged or missing shields. Inspect the shields for missing/loose fittings.
- Ensure the reel bats are in their operational position.
- Thoroughly inspect the hydraulic multicoupler. Clean all debris from the fittings.
- Inspect the hydraulic hoses and replace/repair as needed.
- Apply grease where needed as outlined in section 10.3 on page 56 section of this manual.
- Ensure transport cart axle bolts are installed. If these bolts are removed, the wheels may fall off during transport.
- Take note of items which require attention after the swather is connected to the power unit as outlined in the power unit's operator manual.

This Page Intentionally Left Blank

5 - Installation

5.1 - Preparation - Mechanical

Remove the tilt cylinder pivot bolt on the windrower and replace with longer (3/4" x 4-1/2") bolt that is included in the packing box that comes with the swather.

Install the safety chain lug onto the tilt cylinder pivot on the windrower left hand side and retighten the nut on the bolt to 266 ft-lbs.

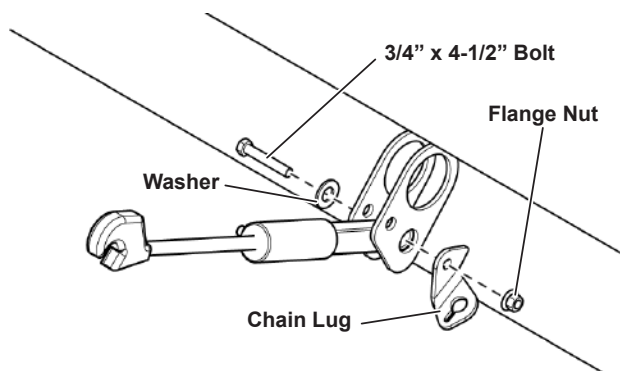

Fig. 22 - Tilt Cylinder

5.2 - Crop Divider Installation

Install the crop divider pipes on the crop dividers, then install the crop dividers on each end of the swather.

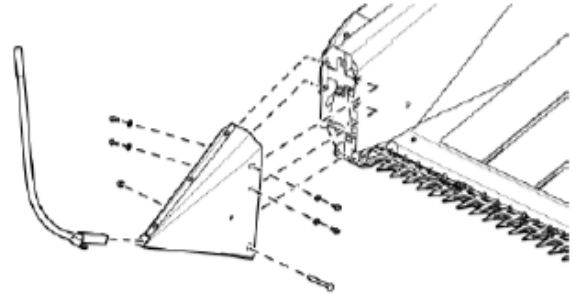

Fig. 23 - Install crop dividers

NOTE:

The crop divider pipes require that you tighten a bolt inside the crop dividers (not shown in the illustration).

The Dividers may be removed when transporting on public roadways in order to comply with width restrictions.

NOTE:

The crop divider pipe is intended to be used when cutting off the ground, the stub nose is to be used when cutting close to the ground.

5.3 - Setting Swather Table Width

The table width should be adjusted to the correct width for the attached table so that GPS and acreage values are calculated accurately.

Set the width value denoted by the icon below on the "Header Setup" screen to the size of the table being used.

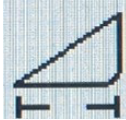

Fig. 24 - Set header width

NOTE:

When changing back to a AGCO Rotary or Sickle bar mower, the "Width" value should be reset to the proper size. See your windrower operations manual for details.

5.4 - Mounting the Swather to the Windrower

1. Park the swather on firm, level ground, where it will be easily accessible for the windrower operator to pick up. Ensure the swather is level.
2. Lower the screw jack, located on the side of the transport axle, and raise the axle until the wheel assembly clears the ground.
3. Remove the quick pin securing the rear hub and spindle, and remove the wheel assembly. Store the wheel assembly in an appropriate location.

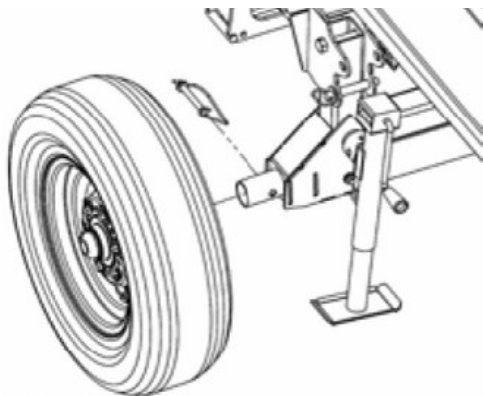

Fig. 25 - Remove wheels

4. On each of the mount pockets, remove the storage pin holding the mount pockets in storage position and store pin in outer holes in frame strut.

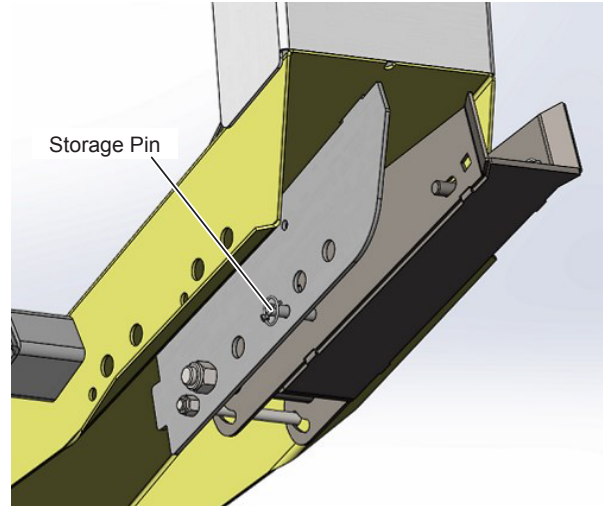

Fig. 26 - Storage pin location (left side shown)

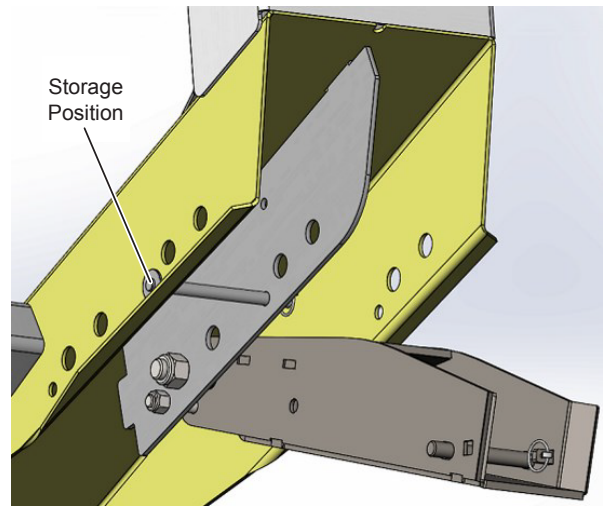

Fig. 27 - Storage pin in storage position (left side shown)

5. Start the windrower and release the float pressure by unloading pressure from the accumulator (see wind-rower operators manual). Once the float pressure is release and you have lower the arms as much as possible, you will have to place a weight on each of the lift arms to get them to lower closer to the ground.

6. Ensure the tilt cylinder is secured out of the way so it does not get damaged when securing the lift arms.
7. Move the windrower into position, lining up the lift arms with the mounting pockets. Ensure the lift arms are low enough to move into the pockets.

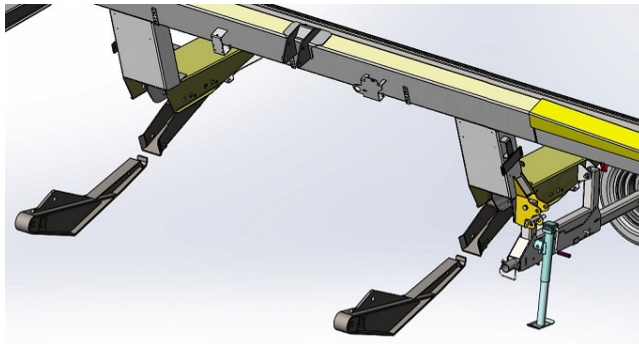

Fig. 28 - Align lift arms

8. Slowly raise the lift arms and move forward until the lift arms are firmly set into the mount pockets. Ensure the end of the lift arm has fully engaged the mounting boot. Do not lift the table any higher at this point.

CAUTION!

Shut the engine down and wait for all moving parts to stop before leave the cab. Ensure the parking brake is on.

NOTE:

The AGCO 9900 windrowers do not have a mechanical lift lock. They have a electrical valve on the main lift cylinder that locks the swather in place when the windrower is turn off.

9. If the arms are located correctly, secure the locking pin in the side of the pocket weldment and install locking lynch pin.

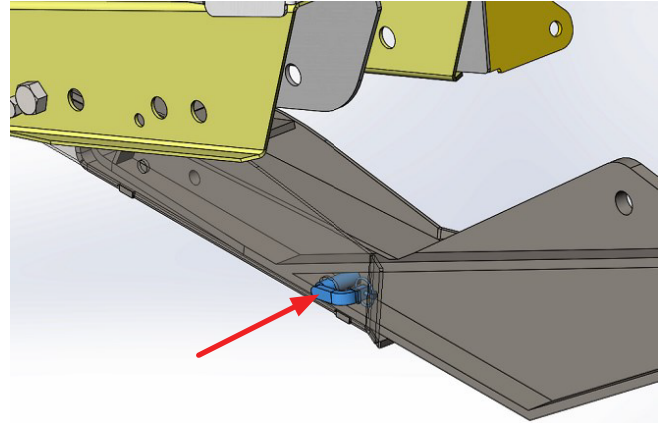

Fig. 29 - Secure lift arms in lift pockets

10. Attach the safety chain to the chain lug (#102752) that was installed on the windrower tilt cylinder pivot. The indicator bolt on the chain marks the minimum length of the chain to be used. Do not remove this bolt.

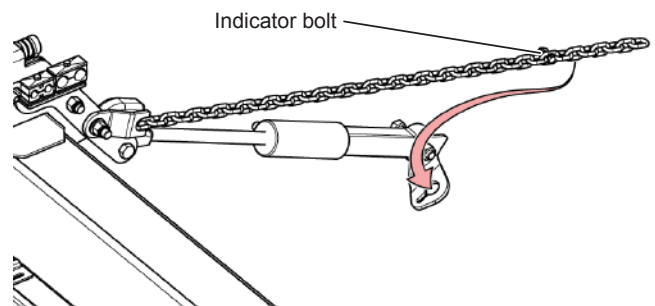

Fig. 30 - Attach safety chain (windrower not shown)

WARNING!

Do not attempt to lift the swather until the safety chain is attached.

11. Start the windrower. Make sure chain is securely attached to chain lug and slowly raise

lift arms until chain becomes tight. It should only take a few inches of lift to tighten the chain.

12. Secure the tilt cylinder to the tilt cylinder brackets on the swather. On the AGCO 9900 windrowers the tilt cylinder can be adjusted outside the cab by activating the external tilt button near the base of the tilt cylinder.

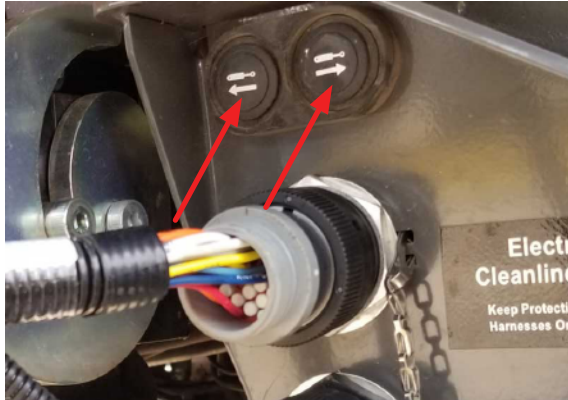

Fig. 31 - External tilt button (9900 series)

13. Lift swather to full height and retract the tilt cylinder fully.

 **NOTE:**

To fully lift swather the float pressure must be increased.

 **CAUTION!**

Shut the engine down and wait for all moving parts to stop before leaving the cab. Ensure the parking brake is on.

 **WARNING!**

Ensure the tilt cylinder and lift arms are firmly locked to the swather and the windrower before proceeding, failure to do so can result the swather suddenly shifting causing equipment damage, injury or death.

5.5 - Store the Transport Axle

1. Remove the wheel assembly from the cutterbar side of the table, and store in an appropriate location.
2. Remove the pin which holds the axle extension in place, from location #1 and slide the axle into the housing.

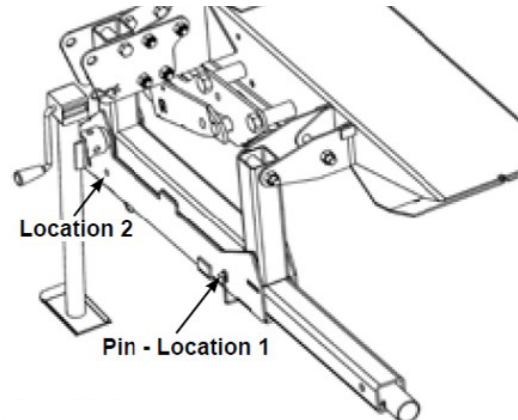

Fig. 32 - Slide axle extension into housing.

3. Secure the axle in the housing by reinserting the pin in location #2 as shown above.
4. Remove the axle jack and remove the pin holding the axle strut in the vertical position.

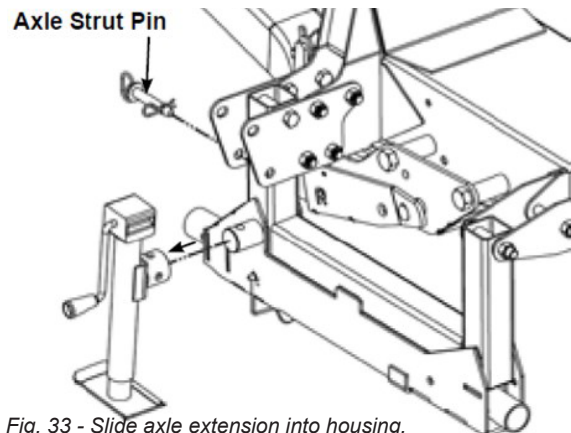
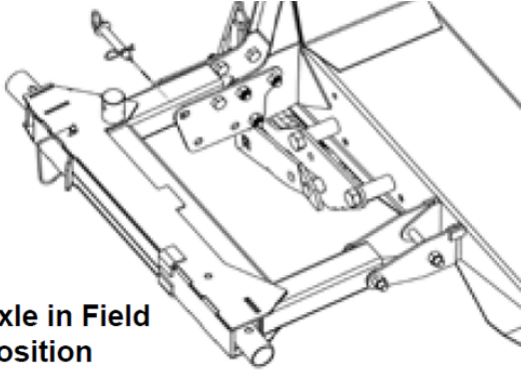

Fig. 33 - Slide axle extension into housing.

5. Swing the axle up, and secure using the pin. Replace the jack as shown and secure with the pin.



Axle in Field Position

Fig. 34 - Secure axle in field position



WARNING!

Transport axle and hitch parts are heavy. Care should be taken when handling them to avoid injury.



NOTE:

On the 15ft WS model the jack cannot be stored on the axle in field position. It must be stored on a storage bracket that is installed on the RH side of the middle strut.



Fig. 35 - Jack stored on side of strut

5.6 - Transport Hitch - Convert to Field Operation (for 21ft+ Tables)

1. Loosen the jack lock pin and remove jack from the hitch tube. Place the jack in its storage position on the end of the swather as shown below.

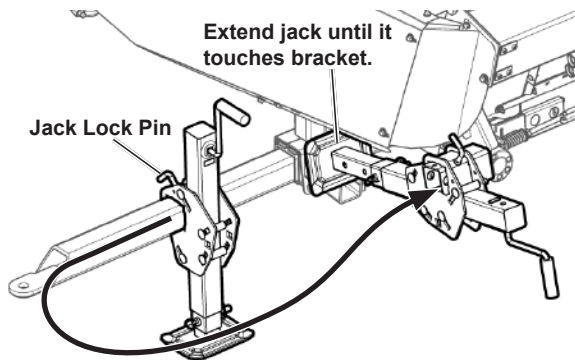

Fig. 36 - Store the Hitch Jack

2. Loosen the hitch tube lock pin and slide the hitch tube to its storage position

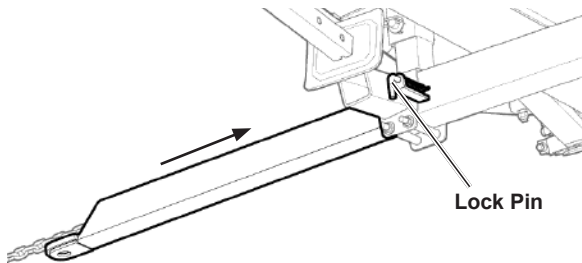

Fig. 37 - Hitch Tube - Storage Position

3. Secure the hitch tube chain to the hitch jack storage bracket as shown below.

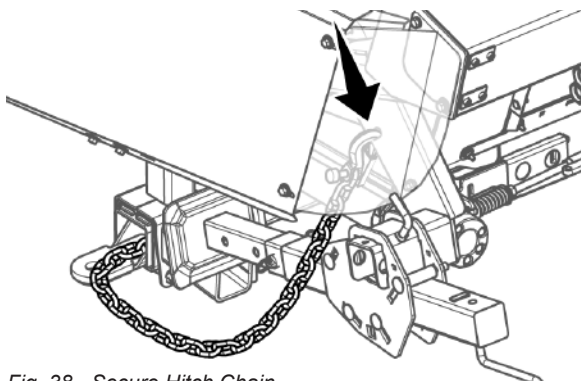

Fig. 38 - Secure Hitch Chain

5.6.1 - Transport Hitch - Optional Removal (for 21ft+ Tables)

If desired, the hitch tube may be removed, if the weight of the swather needs to be reduced, or if the hitch interferes with the ground when cutting at a low angle.

1. Remove pin from the hitch bracket.
2. Lower hitch end to the ground.

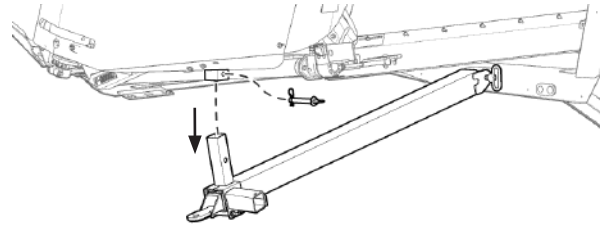

Fig. 39 - Lower End of Hitch Tube

3. Remove pin from the end of hitch tube where it is connected at the strut. Stay clear of hitch tube as it falls.

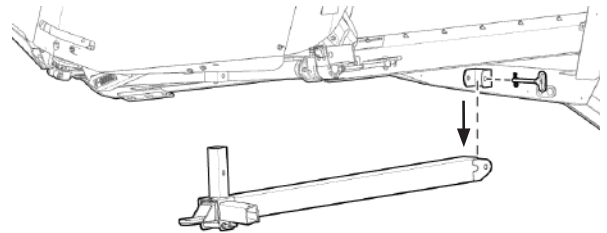

Fig. 40 - Remove Hitch Tube

WARNING!

Hitch parts are very heavy. Care must be taken when handling these parts to prevent injury.

5.7 - Transport Hitch - Convert to Field Operation (for 15ft Tables)

WARNING!

Hitch parts are very heavy. Care must be taken when handling these parts to prevent injury.

1. Remove the pin which secures the hitch to the strut then slide the hitch tube away from the swather. Take care, as the hitch is extremely heavy!

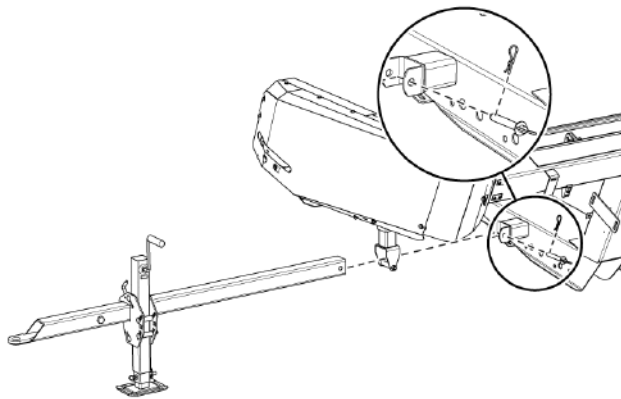

Fig. 41 - Remove 15ft hitch tube

2. Slide the hitch jack off the hitch tube and install it on its storage bracket as shown below. Extend the jack until it is braced against the hitch bracket to prevent the jack from vibrating.

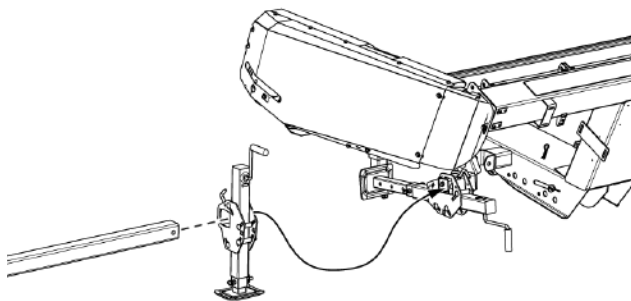

Fig. 42 - Storing hitch jack - 15ft swather

3. Store the hitch tube in a secure location.

5.8 - Connect Electrical and Hydraulic Systems

1. Start the windrower and carefully lower the swather.

NOTE:

To fully lower the swather you may have to decrease float pressure.

CAUTION!

Shut the engine down and wait for all moving parts to stop before leave the cab. Ensure the park brake is on.

2. Connect the hydraulics for the pressure, return, case drain and reel lift to the swather. See illustrations below for specifics.



Fig. 43 - 9900 series couplers

NOTE:

If you need to refer to hydraulic schematic, see section 6.6 on page 36 for hydraulic schematic.

5.9 - Mounting Checklist

- Safety chain lug mounted on windrower tilt cylinder pivot with longer bolt
- Set swather table width
- Mount swather onto windrower
- Safety chain set to chain lug
- Transport axle and hitch tube in storage (field) position
- Transport parts stored for future use
- Gauge wheels installed and secured (if equipped)
- Hydraulic couplers attached to windrower
- Electrical connector attached to windrower
- Reel tie down straps/wires removed
- Deck support bars removed
- Crop dividers and divider pipes installed
- Swather table levelled

5.10 - System Checks

Once installation is completed and checked, the system should be tested to ensure everything is operating correctly. If a fault is detected, troubleshoot, and correct as needed.

NOTE:

The following tests should be completed with an observer present at a safe location with a clear line of sight to the operator. If this is not possible, complete the tests with the cab door open, so the operator can detect unusual noises.

5.11 - Hydraulics, Electric and Mechanical Checklist

- Check all fluid levels and top up if needed.
- Before starting windrower ensure reel fingers are adjusted high enough to clear knife sections.
- Adjust the needle valve (if needed)
- If your swather is 25' or larger, start the windrower, run the engine at low idle. Raise and lower the swather and adjust the needle valve to achieve a suitable rate of movement, given the present engine speed. Advance engine RPM to normal operating range, test the rate again, and adjust as necessary.
- Return the engine to idle RPM. Engage each of the swather controls, one by one, to test the electrical and hydraulic connections. For each system you activate, monitor its readings on the display. The reel fore/aft will not function until the swather is running as it draws hydraulic pressure from the hydraulic system.
- Engage all systems, and slowly advance throttle to normal operating RPM. Check that all systems are running at normal speed with no signs of problems or interference. NOTE: If the swather does not run at all, very slow knife speed (set at 700 RPM from factory) or knife speed is surging excessively, shutdown immediately and refer to diagnostics appendix for troubleshooting advice.
- Stop all systems, turn the engine off. Inspect the swather to ensure everything is secure, and there are no signs of abnormal operating conditions. Make adjustments as required, and retest as necessary.
- Check hydraulic fluid levels and top up if necessary.

6 - Hydraulics

6.1 - Theory of Operation

The Swather uses windrower hydraulics to power the various systems. Return-flow oil is filtered before returning to the windrower.

The reel lift circuit is independent of the main knife/reel/drapper circuit and receives its oil from the windrower through the smallest windrower to swather coupler.

The reel, draper, and knife drive circuits are protected by a pressure relief valve which is factory set to 3000 psi (it is not adjustable).

See section 6.6 on page 36 for hydraulic schematic.

6.2 - Manifold Block Cartridge Locations

Identification stamps can be found on individual parts as well as port stamps on the manifold block itself.

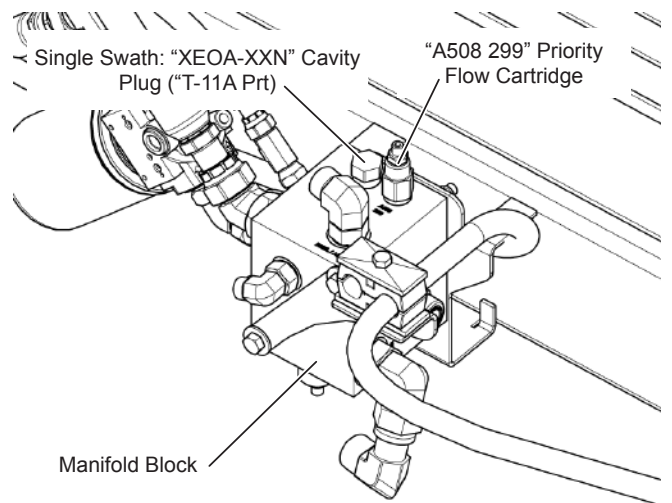

Fig. 44 - Manifold block

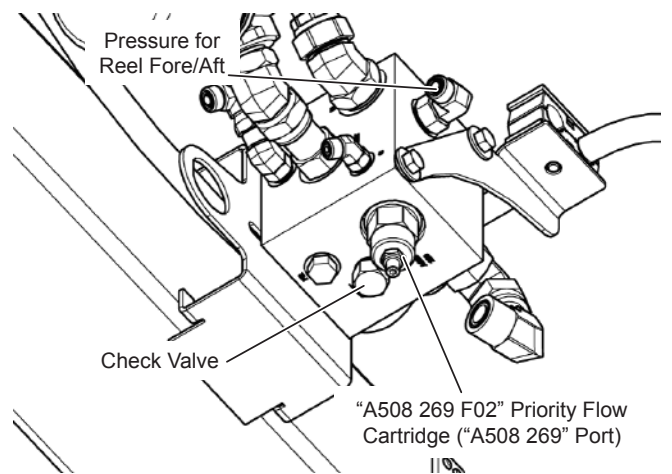

Fig. 45 - Manifold block

6.3 - Hydraulic Operating Pressures

WARNING!

Care must be used when working around pressurized hydraulic systems. Quick couplers must be securely connected before the windrower is started, and power is applied to the swather. Serious injury, and/or damage to equipment may result from poor connections.

The hydraulic pressure of the knife circuit is displayed on the LH upper tube shield. The draper hydraulic pressure is displayed on the gauge located on the left end of the upper tube.

The normal operating pressure for the knife circuit is typical between 1700-2100 psi for a double knife setup when the windrower is operating at normal working RPM, and the oil is at operating temperature.

On cold operating days, it typical for the knife pressure to be running close to relief pressure (3000 psi) until the oil and systems warm up. Allow the windrower and swather to warm up before operating.



Fig. 46 - Hydraulic pressure gauges

Its normal for pressure to fluctuate while cutting due to crop conditions . Other factors that will affect pressure include the condition of the cutting system, and ground speed.

If the swather exhibits excessively knife pressure surging while running, stop down swather/windrower and refer to the troubleshooting section on page 59.

6.4 - Draper and Reel Speed Controls

The draper and reel speed is controlled via the windrower's in-cab controls.

NOTE:

The flow control is equipped with a tamper proof pre set relief valve and a motorized speed control. The relief valve is pre set at 3000 psi (206.9 bar) and is non adjustable. The speed control is electrically adjustable by corresponding controls in the cab.

6.5 - Return Line Filter

This filter cleans the oil as it returns to the windrower. Change this filter after the first 50 hours of operation, and seasonally thereafter. The OEM filter is a Donaldson P164375. A partially plugged oil filter can adversely affect the flow of oil in the system.

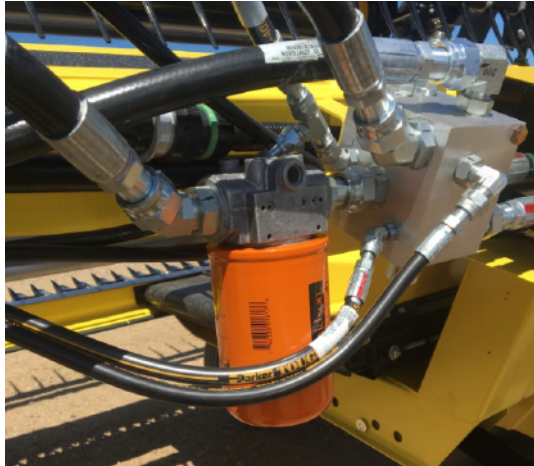
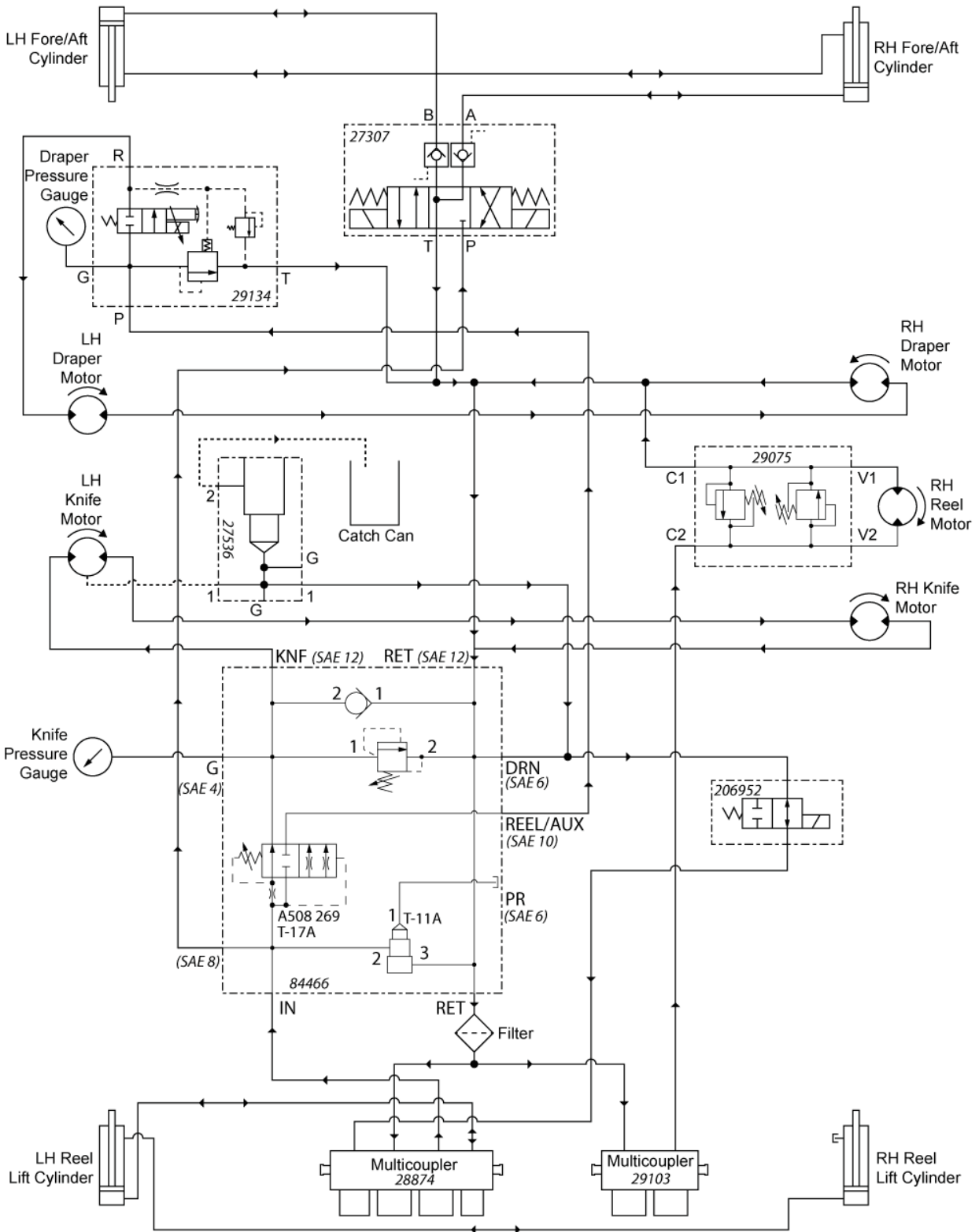

Fig. 47 - Hydraulic return line filter

Compatible Replacement Filters:

- Fleetguard HF6510
- LHA SPE15-10
- Gresen K-2202
- FRAM P1653A
- NAPA 51551
- Stauff SF6520

6.6 - 15ft WSA Hydraulic Schematic



7 - Drapers

There are two lateral drapers on the table which move the crop to the centre opening. All drapers must be maintained properly to perform well. Quick release adjusters with spring tensioning allow easy access for cleaning, and maintain proper draper tension.

CAUTION!

When working on the drapers: Lower the swather to the ground or onto stable blocks, whichever provides the most comfortable working height.

Raise the reel to its maximum height and place the locks on the reel lift cylinders to prevent the reel from falling.

Shut down the power unit and wait for all moving parts to stop before exiting the cab.

7.1 - Lining Up the Idler Roller

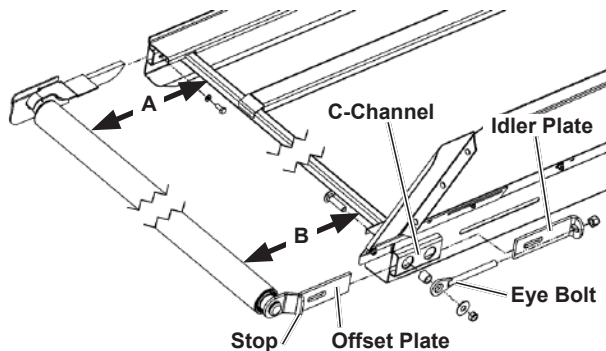

Fig. 48 - Idler Draper Alignment

Prior to installing the draper, ensure that the idler roller (the draper roller without the motor) is properly aligned. This is done by setting the end of the offset plate flush with the c-channel of the deck. Adjust the eye bolt until the end of the idler plate contacts the stop on the offset plate if not so already.

Once extended, you should make sure that everything is parallel. The easiest way to do this, is to measure the distance between the roller and the closest cross brace on the draper deck. Make sure measurement "A" is the same distance as measurement "B". If it still does not line up, you may adjust the eye bolt again.

7.2 - Draper Installation

1. Make sure that the quick release lever is in the open position prior to installing the draper on the deck.

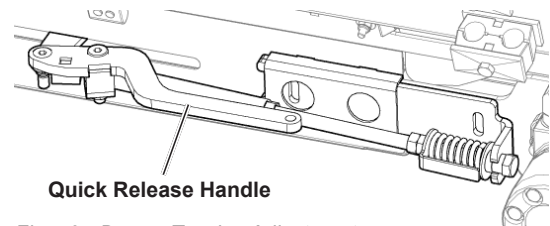

Fig. 49 - Draper Tension Adjustment

2. Place draper bundle on the top of deck runners, and unroll with the slats facing up. Be sure to align the v-guide with the notched side of the roller toward the rear end of the swather.

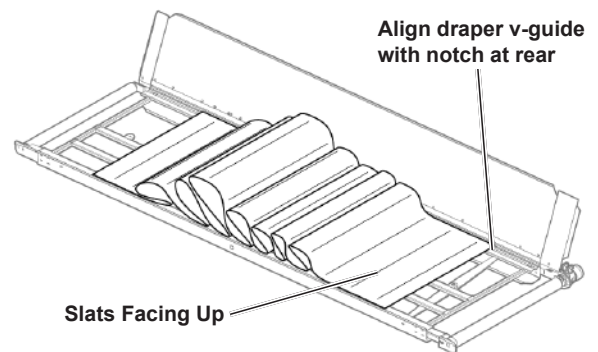

Fig. 50 - Unroll Draper

3. Wrap draper around one of the rollers and feed draper into the bottom runner of the deck. The bottom runners will support the draper, and prevent it from hanging down.

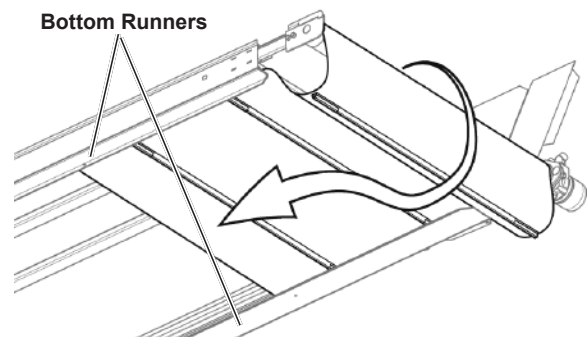

Fig. 51 - Feed Canvas Along Bottom Runners

4. Pull draper through bottom runner, and wrap around the other roller. Pull the ends of the draper together. Install a connector bar to close the joint. Take note of the position of the rounded corners on the connector bar.

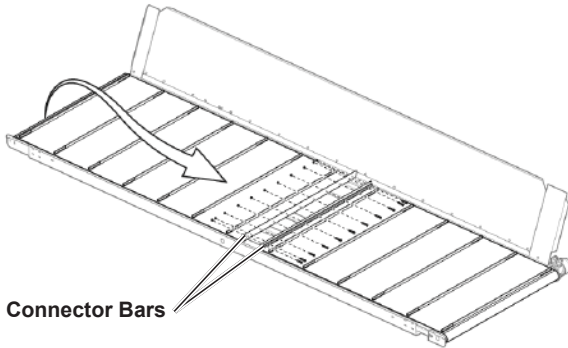

Fig. 52 - Secure Canvas with Connector Bars

5. The heads of the screws for the connector bar should be installed from the centre opening side. This helps prevent the crop being caught on the screws. Complete the installation by adjusting tension and tracking as described on the following pages.
6. Once the draper is installed on the draper deck, close the quick release lever (shown on following page) to apply tension to the draper.

7.3 - Tensioning

Proper tension must be maintained on the draper to prevent slipping on the drive rollers. The draper tension is changed by adjusting the drive roller of each deck.

7.3.1 - Spring Tension Indicator

The spring tensioners are equipped with a spring length indicator to show the proper amount of tension that should be applied when the decks are tensioned, prior to field operation.

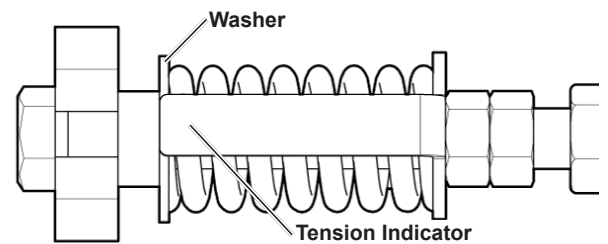

Fig. 53 - Draper Tension Indicator

NOTE:

For proper tension, the tip of the indicator should be even with the end of the spring. This allows for good draper tension, while still having spring compression left over for crop loads on the draper.

To check if tensioning is required:

1. Engage the power unit drive with the engine at low idle.
2. Observe from the cab how the drapers are tracking.

WARNING!

If adjustment is required, lower the swather to the ground, raise the reel and lock in place. Shut down the swather, and turn off the engine before exiting the cab.

If tensioning is required:

1. Adjust the tension by turning the adjuster bolt (Quick Release doesn't need to be released when adjusting).

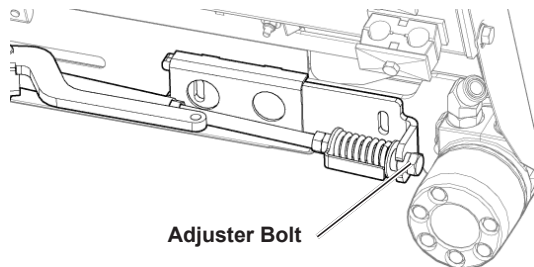

Fig. 54 - Draper Tension Adjustment

- Turn the adjuster bolt clockwise (shorten the bolt) to decrease tension
- Turn the adjuster counter-clockwise (lengthen the bolt) to increase tension.

NOTE:

When increasing tension, do not compress the spring past the indicator tip.

2. Restart the windrower and repeat the running test. Re-adjust as necessary.

NOTE:

When adjusting the draper tension and tracking, check the clearance between the draper deck slats and the end strut.

CAUTION!

Draper tension should be just enough to prevent slipping. Do not overtighten as it may cause failure to the bearings, draper rollers and/ or draper belts.

The draper may be damaged if it, or deck parts contact the end strut.

IMPORTANT!

A minimum of 2" (50 mm) clearance is recommended. If necessary, loosen the deck restrainer and slide deck over.

7.4 - Tracking

The draper must track properly on the rollers to avoid damage to the drapers. The draper decks allow for approximately 1/4" clearance on each side.

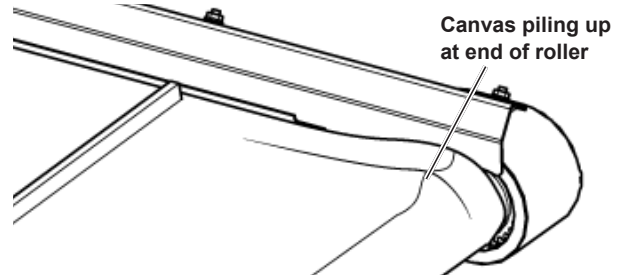

Fig. 55 - Improper Draper Tracking

7.4.1 - Idler Roller Tracking Adjustment

This roller is fixed at the cutter bar, so is adjustable only at the back panel. If the draper is tracking toward the back panel, tighten the nut on the eye bolt (shorten the eye bolt). This will push the idler mount plate and idler roller at the back panel end out, creating more slack in the draper at the cutter bar.

If the draper tracks toward the cutter bar, lengthen the eye bolt. This will pull the idler mount plate and idler roller in, creating slack in the draper at the back panel end.

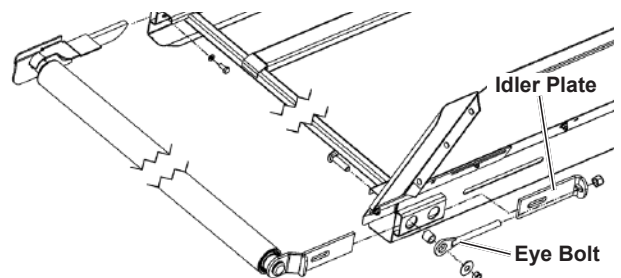

Fig. 56 - Idler Draper Alignment

NOTE:

The draper will track to the slack side.

7.4.2 - Drive Roller Tracking Adjustment

There is no direct adjustment for tracking on the drive roller end. It is self tracking by way of the v-guide in the drive roller and tensioning system

7.5 - Draper Speed

Proper draper speed is critical to the performance of your swather. The draper speed should be balanced with the field speed of the power unit to deliver the material smoothly to the center opening.

The speed of the drapers is controlled via the in-cab controls.

Things to Observe while cutting:

- Excessive draper speeds may form a poor swath. The heads tend to be thrown to the center and can fall through the stubble.
- Draper speeds that are too slow for the field speed tend to overload the decks with cut crop and can result in plugging the cutter bar. In lighter crops, the swath is often too open and may fall through the stubble, making it difficult to pick up.
- Experiment with different draper and field speeds to obtain the best swath formation for the cutting conditions. It may also be necessary to make adjustments as conditions change.

IMPORTANT!

Avoid over speeding the draper. Excessive draper speed will cause premature wear and shorten draper life significantly.

7.6 - Draper Splicing

Regular maintenance will extend the life of your draper. Proper tension and tracking are very important. If material builds up inside the deck, it will wrap around the idler and drive rollers causing the draper to tighten. As the draper tightens, additional stress is put on the motor and the draper. If this condition is not corrected, it will result in failure of the drive roller motor or the draper. Tears in the draper can be caused by poor tracking, foreign materials, or from careless use. If only a portion of draper is damaged, a splice may be installed.

Before beginning this repair, you will need an additional connector bar set and a section of draper that is at least 2 ½" longer than the piece to be removed.

NOTE:

If the damaged section is not near an existing connector bar, you will need 2 connector bar sets and a piece of draper 5" longer than the damaged piece.

1. Raise the swather and install lift cylinder locks. (If this is too high for comfortable access, the table can be set on blocks or lowered to the ground.)
2. Raise the reel and place the locks on the lift cylinders to prevent the reel from falling.

WARNING!

Engage the park brake on the power unit, shut the engine down, and wait for all moving parts to stop before leaving the cab.

3. Release the draper tension.
4. Remove draper connecting bar.
5. Correct the cause of the draper failure.
6. The draper should be cut midway between two slats to provide ample material for the new joint. With a measuring tape, measure, and mark a line six inches from a slat on a good portion of the draper. Place a board directly under the line you have marked, to support the section you will be cutting. With a utility knife and a straight edge cut the draper along

the marks. This cut must be accurate, and square, to assure that the draper will track properly. Repeat this step on the other side of the damaged area.

7. Lay the piece you have removed flat, and measure the width, then add 2 1/2 inches. The total will be the length of material you require for the splice. (If you need two new connector bar sets, add 5".)
8. To mark the location for holes, measure 1" in from each edge to be joined, and mark a line parallel to the cut edges.
9. On each of these lines, measure 1-1/8" from the front edge of the draper, and make a mark for the first hole.

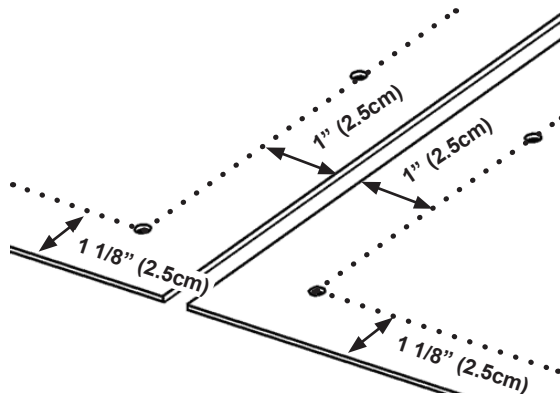

Fig. 57 - Draper Splice Hole Measurements

10. Drill 3/16" holes through each mark.
11. Place the backs of the draper together, lining up these drilled holes.
12. Place a connector bar on each side, line up the holes, and secure with a machine screw and nut.

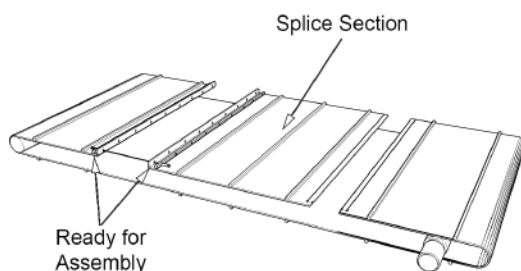

Fig. 58 - Draper Splice

13. Match up the edges of the draper and drill a hole at the opposite end on the 1" line, using the connector bar as a template. Insert a screw and secure in place. Drill the remaining holes through the holes in the connector bar, insert screws and secure.
14. Adjust draper tension. Trim all joins to 1/2" above connector bar.
15. Adjust tracking.

7.7 - Idler Roller Removal

1. Relieve draper tension using the quick release lever.
2. Remove the nut, washer, spacer and bolt that holds the eye bolt and idler plates in place.
3. Slide the idler plate with the eye bolt out of the c-channel as far as possible.
4. Pull the offset plate away from the roller end, letting the roller drop down.
5. Pull the idler roller out of the deck.
6. Check bearings on each end and remove any material build-up on the roller.
7. Re-assemble in reverse order. Adjust tension and tracking as necessary.

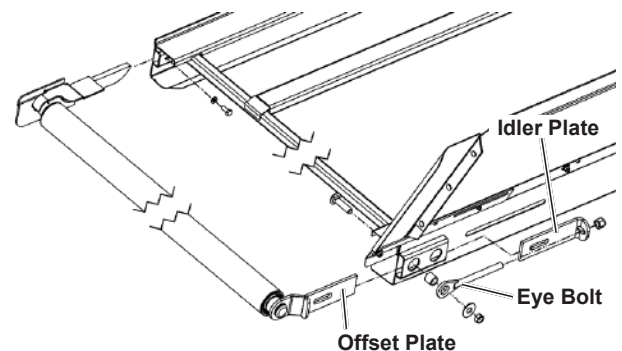

Fig. 59 - Idler Draper Alignment

7.8 - Drive Roller Removal

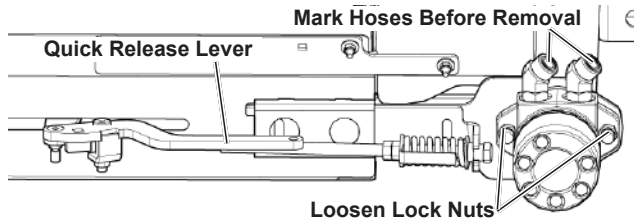

Fig. 60 - Drive Roller Removal

1. Relieve the draper tension using the quick release lever.
2. Mark hydraulic hoses on draper motor. Remove hoses. Insert plugs into hoses and caps on the motor to reduce oil loss and to prevent contamination.
3. Remove the lock nuts that secure the motor onto the motor plate. It is not necessary to remove the adjuster bolt from the motor plate.
4. Pull the motor with drive roller through the hole in the motor plate.
5. Check bearing in end of roller, and remove any build up of material on roller.

NOTE:

Check and remove any built up material from the draper deck runners. If necessary, split draper at connector bar to gain access to inside of the deck.

To re-install drive roller, reverse above procedure. Adjust tension and tracking as necessary.

7.9 - Removing Draper Motor

1. Remove Hex Bolt set screws.
2. Insert two pry bars one on each side of motor, and pry motor out of drive roller. Do not hammer on the housing flanges of the motor. Damage to motor will void warranty.
3. If motor does not move, insert a 7/8" or 3/4" rod through the center of drive roller and apply force directly to the shaft of the motor.

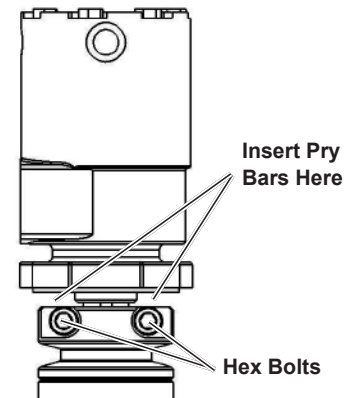

Fig. 61 - Remove Draper Motor

7.10 - Replace Bearings on Drive Roller

The roller bearings are pressed into the rollers with a friction fit and held in place with a retaining ring.

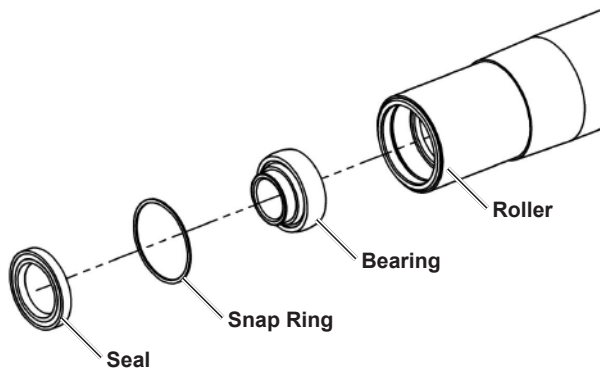

Fig. 62 - Drive Roller Assembly

1. Remove seal that holds the bearing assembly in place. Be prepared to replace the seal with a new one upon replacement.
2. Remove the snap ring that secures the bearing in place.
3. On the opposite end of the roller from the bearing to be removed, insert a small rod through the inside of the roller and push the bearing out.
4. Drive bearing out with the rod.
5. Install new bearing, and replace the retaining ring and seal.

7.11 - Replace Bearings on Idler Rollers

The roller bearings are pressed into the rollers with a friction fit and held in place with a retaining ring.

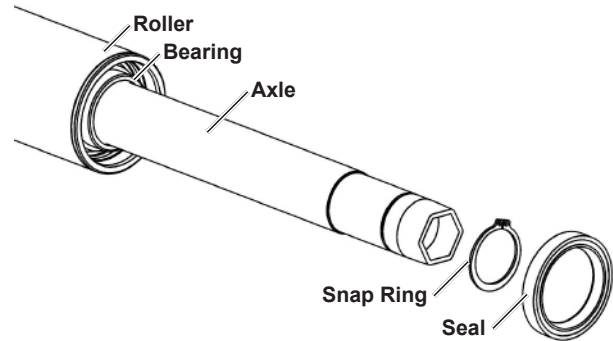

Fig. 63 - Idler Roller Bearing

1. Remove seal that holds the axle and bearing assembly in place. Be prepared to replace the seal with a new one upon replacement.
2. Remove the snap ring that secures the bearing and axle in place.
3. Grab the axle and pull it out of the roller, ensure that you pull the side with the hexagon end out first.
4. On the opposite end of the roller from the bearing to be removed, insert a small rod through the inside of the roller and push the bearing out.

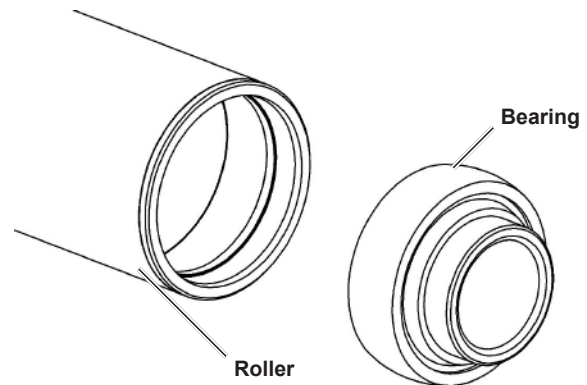

Fig. 64 - Idler Roller Bearing

5. Install new bearing, and replace the axle, snap ring and seal.

7.12 - Installing Draper Motor

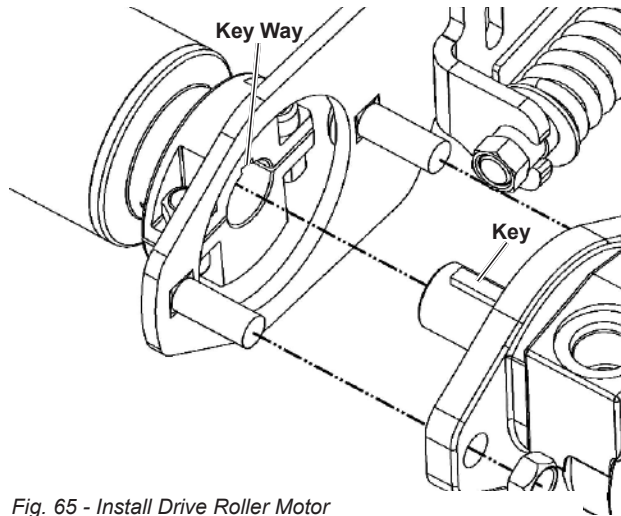

Fig. 65 - Install Drive Roller Motor

1. Clean motor shaft and hub of drive roller. Apply anti-seize to shaft.
2. Insert key in motor shaft.
3. Insert motor into hub, lining key on shaft with the key-way in the hub. Do not use a hammer on housing flange; damage of this nature to the motor will void warranty. Use a soft blow or rubber hammer to apply force to end of motor.
4. Tighten set screws.

7.13 - Draper Deck Maintenance:

To be performed at least once a year (or as necessary).

- Remove draper connector bar.
- Remove draper - clean draper of debris, both sides.
- Store draper indoors.
- Clean debris from rollers, deck channels, and runners.
- Check idler roller bearings; they should spin freely.
- Check drive roller bearings.

NOTE:

If you elect to store the swather outside with draper installed, position the connector bar on the underside to aid water drainage. Ice buildup underneath could cause draper to sag and drop out of the lower runner. If this is not noticed and corrected, damage may occur to draper on startup.

8 - Reel

8.1 - Set Reel Safety Stops

Raise reel completely and engage safety stops on reel lift cylinders at each end of the swather. The stop must be secured in place over the cylinder with the lock pin.

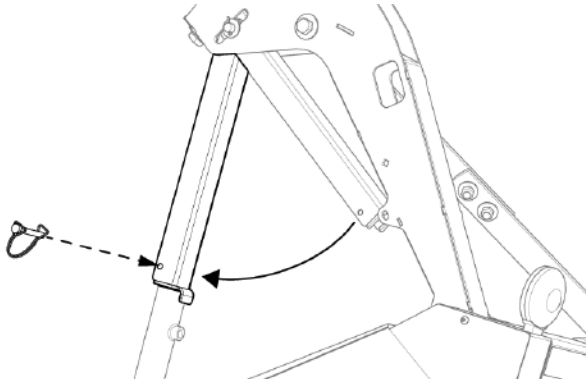

Fig. 66 - End Reel Arm Safety Stop

8.2 - Reel Drive

The reel is driven by a hydraulic motor on the right end of the table with a direct drive coupler to the reel.

Check coupler bolts and motor mount bolts regularly for tightness. Check alignment of motor to reel tube, and shim the mounting bolts if needed.

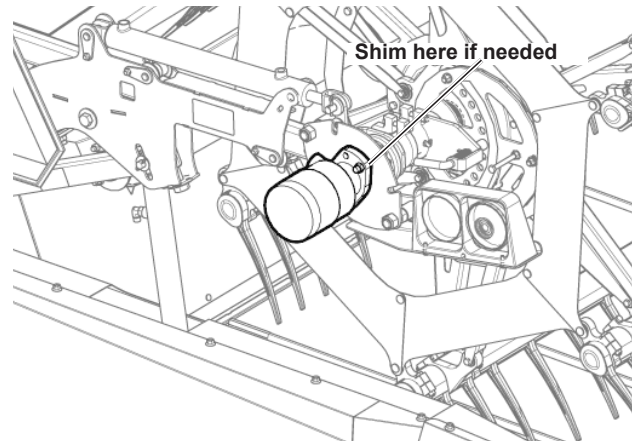

Fig. 67 - Reel Drive Alignment



IMPORTANT!

Reel motors are capable of bidirectional operation. As installed on the swather they run in one direction only and are supplied with unidirectional hydraulic oil flow. For this reason, it is important to mark the lines and their corresponding motor ports whenever you are removing hydraulic lines.

8.3 - Reel Speed Adjustment

“Down” crops will require a somewhat higher speed than standing crops. Reel speed is determined by a control in the windrower. Adjust the reel speed so that the reel has the appearance of “pulling” the swather through the field.

- If reel speed is set too slow, the crop will not be pushed against the cutter bar and swept onto the draper. This can result in a portion of the cut crop being pushed forward onto the ground. Slow reel speed may also cause a wrapping of the reel with cut crop, as it bunches along the front of the cutter bar. It is very important that the reel gently guides the crop onto the cutter bar, then sweeps it onto the draper.
- If reel speed is too high, the crop may be stripped or shelled out by the impact of the reel. The crop may also be pushed down before it can be cut, leaving uncut grain in the field. Excessive reel speed may also cause cut crop to wrap onto the reel, as the crop does not get a chance to fall onto the draper.
- In general, hay crops can be cut using higher reel speeds.

8.4 - Reel Position

8.4.1 - Hydraulic Fore & Aft

All reels are equipped with hydraulic fore and aft, controlled from the power unit. This feature allows the operator to move the reel assembly forward and backward.

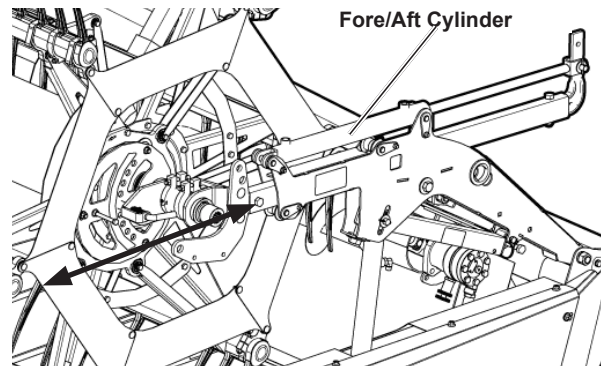

Fig. 68 - Fore/Aft Cylinder

8.5 - Reel Arm Leveling and Height Adjustment

Honey Bee swathers are equipped with adjustable reel height, which limits how much the reel can be lowered, and how close the reel can come to the cutter bar. The reel height is adjusted by tightening or loosening the bolt immediately in front of the reel lift cylinder.

To adjust the height:

1. Start the power unit and fully lower the reel.

WARNING!

Engage the parking brake, shut the power unit down, and allow all moving parts to come to a complete stop before exiting the cab.

2. Using a 1-1/8" wrench or socket with ratchet, tighten (turn clockwise) the bolt to raise reel and loosen (turn counter clockwise) to lower the reel. Ensure you have minimum clearance of approximately 2.0" (50 mm) of the reel tines to the cutter bar.

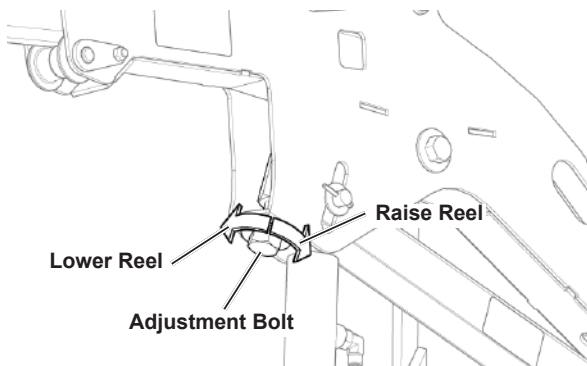

Fig. 69 - Center Reel Arm Height Adjustment

3. Repeat this procedure for right side of the swather, ensuring that you have a minimum of 2.0" (50 mm) clearance of the reel tines with the cutter bar.

4. If possible, rotate reel by hand to ensure the reel tines will not contact any part of the deck, draper, or cutter bar.

WARNING!

When servicing the reel, it is necessary to have the reel locked into the servicing (highest) position, with the lock pins securely in place.

8.6 - Reel Centering

Measure the clearance from the end shield on the reel to the crop divider on each end of the swather. See the illustration below.

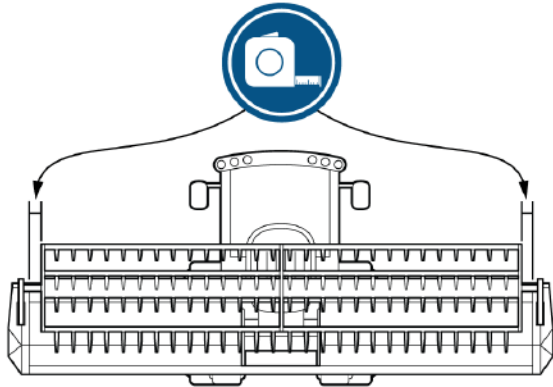

Fig. 70 - Reel Centering

If the reel is not centered on the swather, proceed as follows:

WARNING!

Fully lower the table and reel, and engage parking brake. Engage the parking brake, turn power unit off and allow all moving parts to come to a complete stop before exiting the cab.

1. Loosen the carriage bolts that secure the reel arm braces on both ends of the reel.
2. Push the reel arms until reel is centered.
3. Tighten bolts when centered.

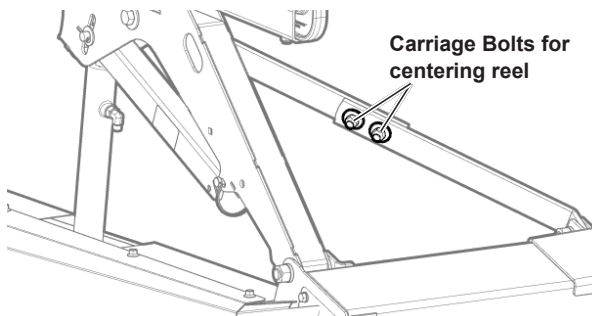

Fig. 71 - Loosen bolts to adjust reel position.

8.7 - Honey Bee Reel Tine Pitch Adjustment

1. Pull and rotate lock pin to one side so it is disengaged from reel.
2. Lift the handle up for less aggressive tine pitch.

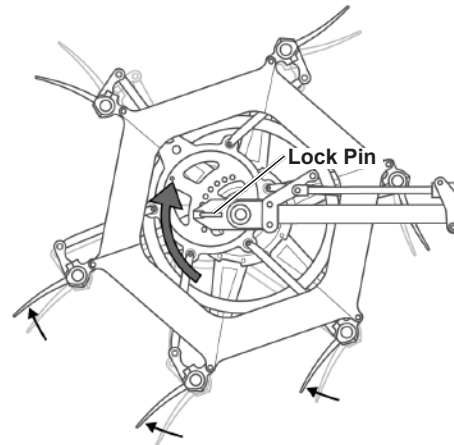

Fig. 72 - HB Reel - Decrease Tine Pitch

3. Lower the handle for more aggressive tine pitch.

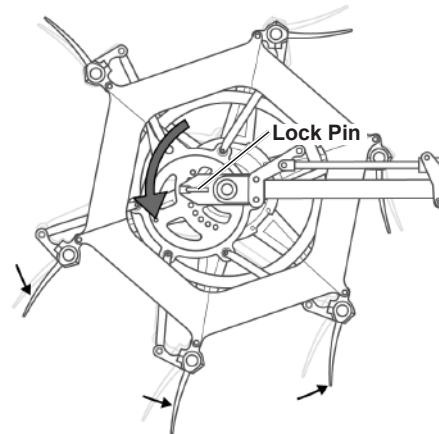

Fig. 73 - HB Reel - Increase Tine Pitch

4. Once desired setup is obtained, re-engage the lock pin.
5. Repeat this process for the other end of the reel to ensure each side has identical tine pitch.
6. Readjust reel height and reel fore/aft in order to maintain a minimum safe knife clearance (2" (5 cm)).

8.8 - Reel Finger Replacement

WARNING!

To avoid serious injury, completely raise reel, engage reel lift safety stops, shut OFF engine, set parking brake, and remove key.

1. Using a pair of slip-joint pliers, grab, squeeze and pull to remove the spacer next to the reel finger to be replaced.

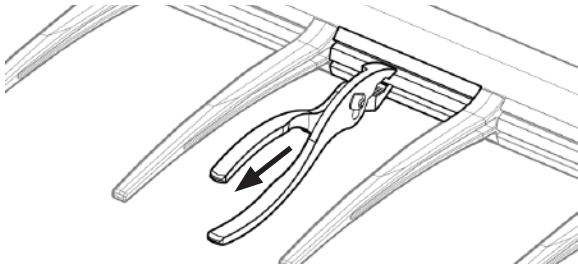

Fig. 74 - Remove reel finger spacer

2. Twist the reel finger counter-clockwise and pull to remove it from the channel.

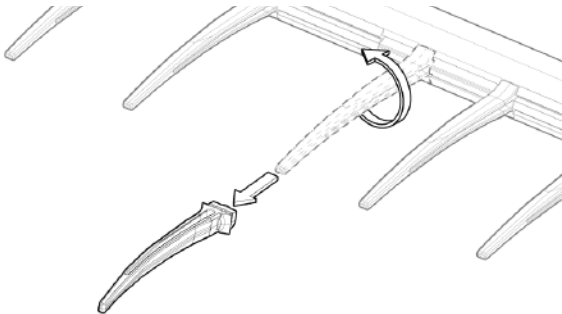

Fig. 75 - Twist clock-wise and pull to remove finger

3. Reverse the above procedure to install the new reel finger.

NOTE:

If multiple reel fingers are being replaced, only 1 spacer must be removed, the remaining spaces can be slid side to side while installing the fingers.

8.9 - Rephasing Reel Cylinders

If cylinders become unevenly extended:

Fully retract the cylinders and hold the cylinder retract switch for a few seconds to remove air from the system.

8.10 - Reel Speed Sensor Adjustment

The speed sensor on the swather is adjusted to its optimal position in the factory but may require adjustment if it is replaced or serviced.

In order for speed sensors to work properly, they must be 0.90-0.95mm (0.035-0.037 in.) away from the surface they are measuring.

For each sensor, 1 full rotation of the adjuster nut equals approximately 1 mm of travel, so to get the best distance, screw in the sensor until it is just touching its measuring surface then back it off 90-95% of a turn.

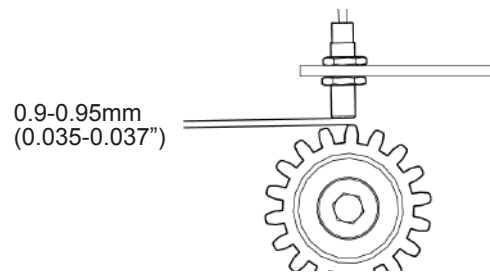

Fig. 76 - Speed Sensor Spacing

8.11 - Check Points Before Operating the Reel:

WARNING!

Always engage reel lift cylinder locks and table lift cylinder locks before working under or around raised reel. Do not rely on the power unit hydraulic system for support. A rupture or a leak in any part of the system will cause the table and reel to drop if the proper stops are not in place.

- All bolts are tight.
- Reel turns, by hand, without binding. (With some resistance from hydraulics.)
- Tines uniformly clear the knife.
- Reel arms are aligned. (No bow in the bat shaft or pivot bracket bat assemblies.)
- Auxiliary fingers have adequate clearance with side shields.
- Tine pitch has been set for the current application, and is uniform across swather.
- Hydraulic cylinders are functioning smoothly.
- Minimum reel height has been set correctly on the reel height control arms.
- Fore & aft hydraulic cylinders extend and retract fully.
- Vertical distance from the knife to the reel center is set for the current application.
- Reel is horizontally centered in the swather opening.

9 - Swather Transport & Storage

9.1 - Read before Transporting

There may be regulations restricting transport of heavy equipment on in your area. Be aware of local regulations before transporting.

When transporting your swather via trailer or transport cart, your local regulations may require a maximum equipment width of 8 ft. (2.44 m). To achieve this width, lower the front-most reel fingers into their transport position and remove the crop dividers as outlined in this section of the manual.

WARNING!

Do not exceed 25 mph (40 kph) when towing the swather via transport cart. Excessive speeds can result in injury or equipment damage and may not be permitted by regulations in your area.

Do not transport swather without wheel axle pins installed!

9.2 - Transporting on Windrower

WARNING!

Avoid transporting the swather on the front of a windrower on public roadways whenever possible. The extreme width of the swather, combined with low visibility can pose danger to the equipment operator and the public.

- Reflective material must be clean and visible
- A spotter or pilot vehicle should be used when there is the possibility of encountering traffic.
- Drive at a speed that is safe for conditions.
- Raise the swather to ensure safe clearance from the road while still allowing optimal visibility from the windrower cab.
- The reel must be completely retracted and at an appropriate height for maximum visibility.
- When transporting on public roads, flashing warning lights and tail lights on both sides provide warning to other vehicles. Warning lights are required when driving a windrower on public roads.
- Operators should be aware of the assembled width of the swather and windrower, and must check local regulations before transporting on public roadways.

9.3 - Transporting on Transport Axle

WARNING!

Before transporting the swather, ensure all transport lights and reflectors are in place, clean and functional. Follow all local rules and regulations. Failure to do so can result in equipment damage, injury or death.

1. Fully retract and lower the reel.
2. Park the windrower on firm level ground.

WARNING!

Engage the parking brake, shut the power unit down, and allow all moving parts to come to a complete stop before exiting the cab.

3. Disconnect all electrical and hydraulic connections between the swather and windrower.
4. Remove the transport hitch jack from its storage position then reinstall it onto the transport hitch.
5. Install the transport hitch onto the swather. Extend the hitch jack so it can hold up the table when disconnected from the windrower.

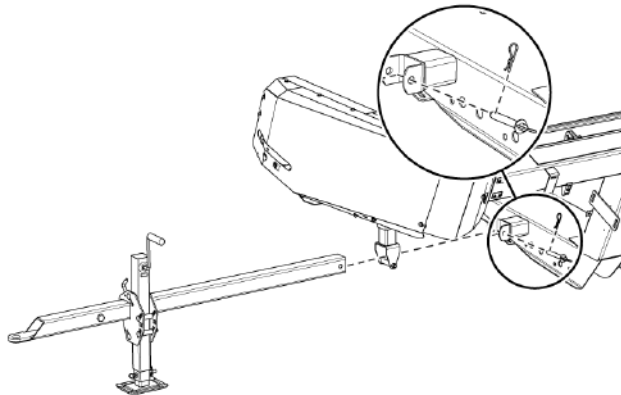

Fig. 77 - Install the transport hitch

6. Lower the transport axle into its transport position and secure it in place with the lock pin. Move the transport axle jack onto the axle as shown below and secure it with its lock pin.

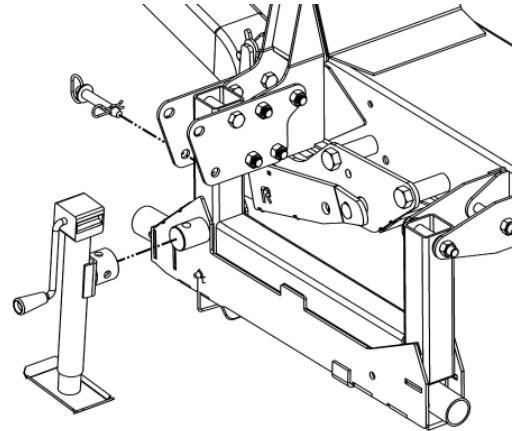

Fig. 78 - Lower axle to transport position

7. Remove the hitch pin securing the extension inside the axle. Pull out the extension and relocate the pin to secure it for transport.

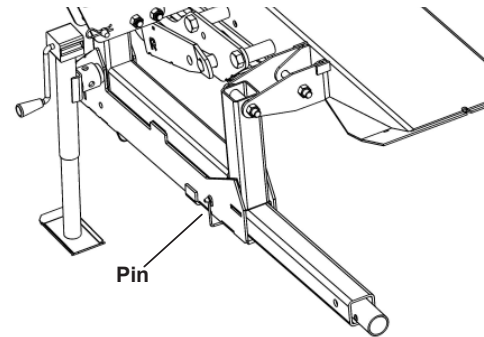

Fig. 79 - Pull out and secure axle extension

8. Install the wheel assembly onto the extension on the cutterbar side of the table, insert lock pin into spindle mount and secure with safety clip.

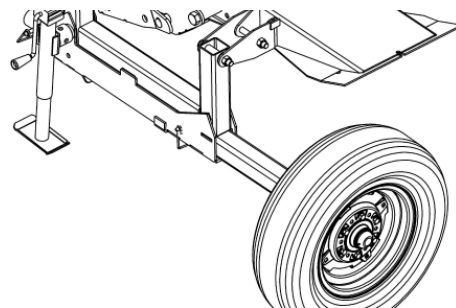

Fig. 80 - Install wheel on axle extension

9. Extend the axle jack until it is roughly level with the installed wheel so it can support the weight of the rear of the table when disconnected from the windrower.
10. Restart the windrower. Lower the swather until the front transport axle wheel, transport screw jack and hitch tube jack just touch the ground. The lift arms should still be firmly set in the strut mounting boots.

! WARNING!

Engage the parking brake, shut the power unit down, and allow all moving parts to come to a complete stop before exiting the cab.

STOP IMPORTANT!

Block the wheel to prevent the windrower from rolling.

11. Disconnect the hydraulic tilt cylinder from the swather and secure out of the way.
12. With the float pressure still set at minimum, carefully lower the swather so that the weight is fully on the front wheel, hitch and rear axle.

! WARNING!

Engage the parking brake, shut the power unit down, and allow all moving parts to come to a complete stop before exiting the cab.

13. Remove the pins securing the lift arms to the lift boots.
14. Restart the windrower and continue to lower the lift arms while slowly backing away until the lift arms are clear of the boots. For ease, additional lift arm pressure can be relieved at this point by opening the windrower's manual float release valve.

! CAUTION!

If the swather moves, stop immediately and find the cause.

! WARNING!

Once clear of the swather, engage the parking brake, shut the power unit down, and allow all moving parts to come to a complete stop before exiting the cab.

15. Attach the rear wheel and secure with the hitch pin

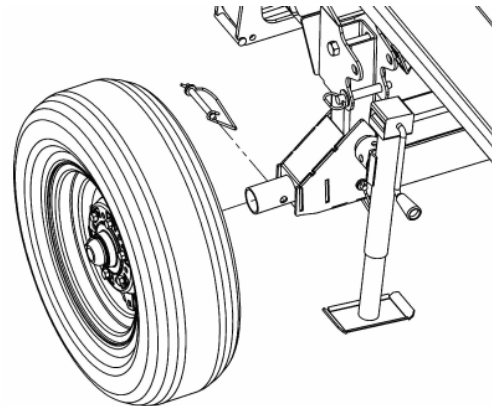

Fig. 81 - Install & secure rear wheel

16. Retract and remove the jack from the transport axle, then return it to its storage position.
17. Check that the swather is level. If necessary adjust the height of the hitch jack.
18. Secure the lift boots in their storage position.

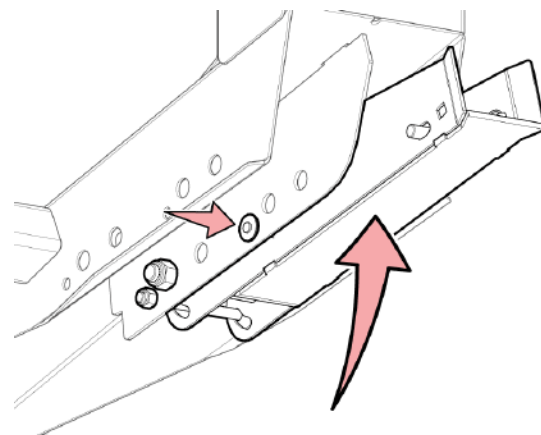

Fig. 82 - Store lift arm boots with storage pin

9.4 - End of Season Storage

- Lower swather onto transport axle and hitch or blocks.
- Completely lower and retract the reel.
- Inspect the swather and clean all chaff and debris.
- Loosen tension on side draper belts (See section 7.3 on page 38).
- Lift up on side drapers and power wash inside belts. Make sure to wash away all chaff and debris.



IMPORTANT!

Do not use high-pressure washer spray directly on electronics, bearings, decals, or any other sensitive areas. High-pressure water can remove seals, lubricants, decals, and damage electrical systems.

- Apply grease where needed as outlined in section 10.3 on page 56 of this manual.
- Paint all parts where paint is worn or chipped.
- If possible, shelter swather in a dry place.

10 - Regular Service & Adjustment

WARNING!

The swather contains many high speed mechanical components. If these components become damaged, it is extremely important that they be repaired as soon as possible. Running equipment with misaligned or damaged parts can cause additional damage to surrounding components, as well as increase the risk of fire.

10.1 - Fasteners

During operation, vibration can loosen fasteners on various components of your swather. Parts with thinner metal such as safety shields tend to vibrate more than other parts, so particular care must be taken to ensure they are firmly secured.

Always ensure that all fasteners are torqued to the proper specifications (see page 58) Apply thread lock compound when necessary.

10.2 - Permanent Bushings

Inspect sealed bearings and permanent bushings every 200 hours of operation and replace as necessary.

See section 10.2 on page 55 for bushing locations.

IMPORTANT!

Do not lubricate the permanent bushings. These bushings are self-lubricating. Added grease will drastically shorten their lifespan.

10.3 - Lubrication

10.3.1 - Grease

It is extremely important that you are aware of ALL lubrication points on the swather (see following page).

Repack the transport wheel bearing once a year if used on roads.

Use grease based on NLGI consistency numbers and expected air temperature range during service interval.

The following grease is recommended: NLGI Performance Classification GC-LB. GC-LB means bearing and chassis-load bearing. #2 EP GC-LB is the most common grade of automotive grease. EP = Extreme Pressure fortified, which is desirable.



IMPORTANT!

Some types of grease thicken and are not compatible with others.

If a grease fitting is missing, replace immediately. Clean fittings thoroughly before using grease gun.

10.3.2 - Alternative and Synthetic Lubricants

Conditions in certain geographical areas may require lubricant recommendations different from those printed in this manual. Consult your dealer to obtain information and recommendations.

Synthetic lubricants may be used if they meet the requirements as shown in this manual.

The temperature limits and service intervals shown in this manual apply to both conventional and synthetic lubricants.

Re-refined base stock products may be used if the finished lubricant meets the performance requirements.

10.3.3 - Lubricant Storage

Your equipment can operate at top efficiency only when clean lubricants are used.

Use clean containers to handle all lubricants. Dirty lubricant = grinding paste!

Store lubricants and containers in an area protected from dust, moisture, and other contamination. Store containers on their side to avoid water and dirt accumulation.

Make certain that all containers are properly marked to identify their contents.

Properly dispose of all old containers and any residual lubricant they may contain.

10.3.4 - Mixing of Lubricants

In general, avoid mixing different brands or types of oil. Oil manufacturers blend additives in their oils to meet certain specifications and performance requirements.

Mixing different oils can interfere with the proper functioning of these additives and degrade lubricant performance.

Consult your dealer to obtain specific information and recommendations.

10.3.5 - Lubrication Interval Chart

	Location	Type of lubrication	Lubrication Interval
A	Knife Drive	Lithium Grease - 5 Shots	50 Hours
B	Knife Drive bearing	Lithium Grease - 1 Shot	50 Hours
C	Reel	Lithium Grease - 1-2 shots	10 Hours
	Knife	Water/Diesel	If knife is gumming up

All other rotating elements on this product use sealed bearings and permanent bushings (not shown). These must be replaced if worn. Typically, loose = worn. Consult your dealer for recommendations.



IMPORTANT!

To avoid equipment damage and system contamination, always clean grease fittings before and after lubrication. If a grease fitting is damaged or missing, replace it immediately. Always tighten plugs securely.

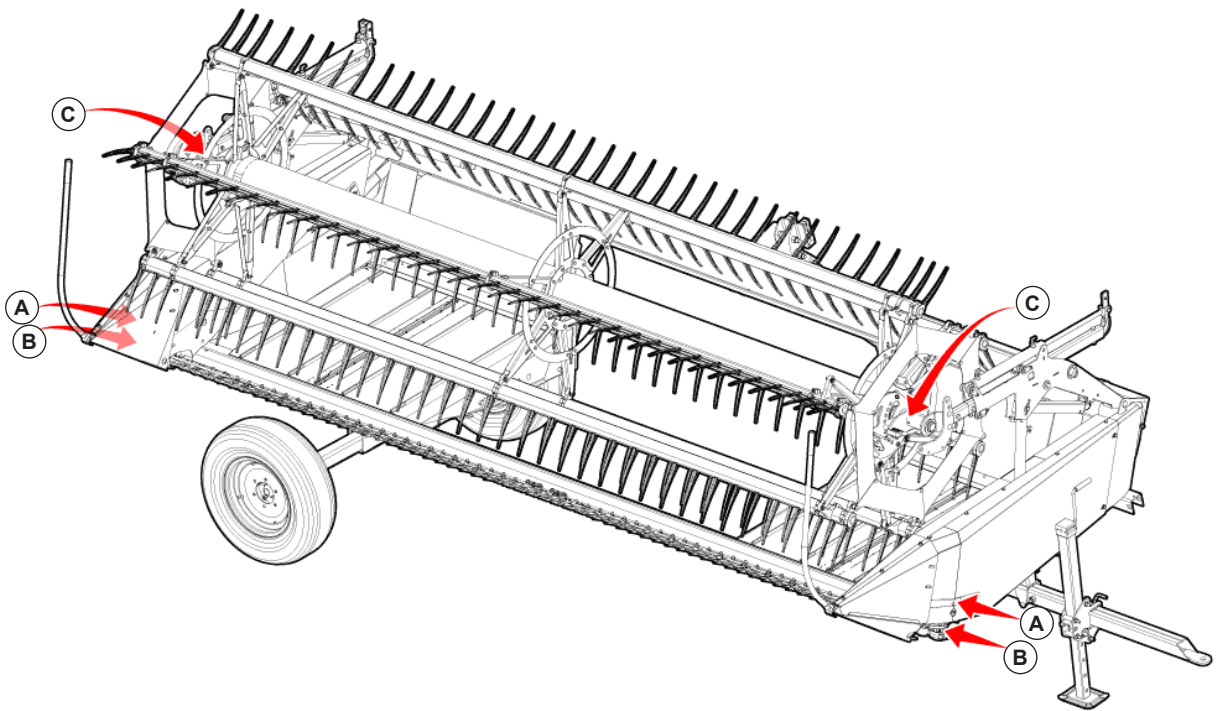

Fig. 83 - Grease Locations

10.4 - Recommended Torque Values (ft-lb)

Use the values listed below unless otherwise stated in this operator manual.

Torque Values when using UNC nuts.					
Bolt Size	Grade 5		Grade 8		Wrench Size
	Loctite	No Loctite	Loctite	No Loctite	
1/4	6	8	9	12	7/16
5/16	13	17	18	25	1/2
3/8	23	31	35	44	9/16
7/16	35	49	55	70	5/8
1/2	55	75	80	107	3/4
9/16	80	109	110	154	13/16
5/8	110	150	170	212	15/16
3/4	200	266	280	376	1-1/8
7/8	320	429	460	606	1-3/8
1	480	644	680	909	1-1/2
1-1/8	600	794	960	1287	1-11/16
1-1/4	840	1120	1360	1875	1-7/8
1-3/8	1100	1469	1780	2382	2-1/16
1-1/2	1460	1950	2360	3161	2-1/4

Torque Values when using C Lock Nuts					
Bolt Size	Grade 5		Grade 8		Wrench Size
	Loctite	No Loctite	Loctite	No Loctite	
1/4	7.6	11.1	10	14.7	7/16
5/16	14.1	21.1	15.2	22.3	1/2
3/8	23	37	28	39	9/16
7/16	39	59	44	60	11/16
1/2	53	80	63	88	3/4
9/16	77	120	98	134	7/8
5/8	106	158	127	172	15/16
3/4	190	274	218	295	1 1/8
7/8	n/a	n/a	317	440	1 5/16
1	n/a	n/a	506	651	1 1/2

11 - Troubleshooting

11.1 - Reel

Symptom	Possible Cause	Solution
Reel Wrapping in Tangled and Weedy Conditions	Incorrect reel location.	Adjust reel forward and down.
	Reel speed too fast.	Slow reel until crop flows smoothly onto belts.
	Reel fingers not able to eject material properly.	Adjust reel timing to more aggressive setting (lower number)
Reel Carrying Around Crops or Excessive Shattering of Grain Heads	Reel speed too fast.	Slow reel speed. Reel should turn slightly faster than ground speed.
	Reel height too low.	Raise reel height to reduce amount of straw gathered by reel.
	Pickup fingers pitched too much.	Reduce finger pitch by adjusting reel timing to next less aggressive setting (higher number)
	Pickup fingers too tightly spaced	Replace 2.5" spaced reel fingers with 5" spaced reel fingers (remove every 2nd finger).
Uneven Reel Height and Fore/Aft	Reel cylinders out of phase.	Rephase cylinders (see section 8.9 on page 49).
	Reel stops not set to same height	Adjust reel stops.
Cutterbar Plugging or Slug Feeding	Reel speed too slow.	Increase reel speed.
	Reel too far forward	Retract reel
	Reel fingers too far from cutter bar	Lower Reel

11.2 - Drapers

Symptom	Possible Cause	Solution
Drapers are slipping	Draper tension too loose.	Adjust draper tension (7.3 on page 38)

11.3 - Cutting Platform

Symptom	Possible Cause	Solution
Shattering of Grain Ahead of Cutterbar	Reel speed not matched to ground speed, causing crop to be overly disturbed before it is cut.	Adjust reel speed to match with ground speed so reel moves crop evenly. Reel should turn slightly faster than ground speed.
	Reel is positioned too low.	Raise reel.
	Reel speed too fast	Slow down ground speed so reel does not hit crop, causing it to shatter.
	Ground speed too slow for conditions of crop.	Increase ground speed so crop 'pressure' is increased, forcing more product onto the drapers.
	Reel too far forward	Position the reel above the cutter bar.
Cut Crop Building Up and Falling from Front of Cutterbar or Loss of Grain Heads at Cutterbar	Reel not adjusted low enough for good delivery of cut crop to belts.	Set reel low enough to sweep material from cutterbar.
	Ground speed too slow for crop conditions.	Increase ground speed so crop 'pressure' is increased, forcing more product onto the drapers.
	Reel too far forward.	Move reel closer to cutterbar.
	Swather tilted too far forward.	Tilt swather back.
Ragged and Uneven Cutting of Crop	Knife dull.	Replace knife.
	Cutterbar plugged with material.	Adjust reel to sweep material off cutterbar.
	Knife sections damaged.	Replace damaged sections.

11.4 - Cutting Platform (continued)

Symptom	Possible Cause	Solution
Excessive Knife Drive Loads or Inconsistent Cut Heights	Dull knife sections.	Replace knife sections.
	Dull knife guard edges.	Replace knife guards.
	Excess binding between top of knife sections and top of guard slots.	Inspect for bent guards, bent cutterbar, or improper position of guards.

11.4.1 - Miscellaneous

Symptom	Possible Cause	Solution
Uneven or Bunched Feeding of Crop	Cut crop not being separated from uncut crop at cutter bar.	Adjust reel settings as described in section 8 on page 45.
	Draper tension is too loose	Increase draper tension
Hydraulic Leak Detected At Multi-Coupler	Leaking O-ring.	See your dealer.

11.5 - Electrical Schematic

11.5.1 - Electrical Overview

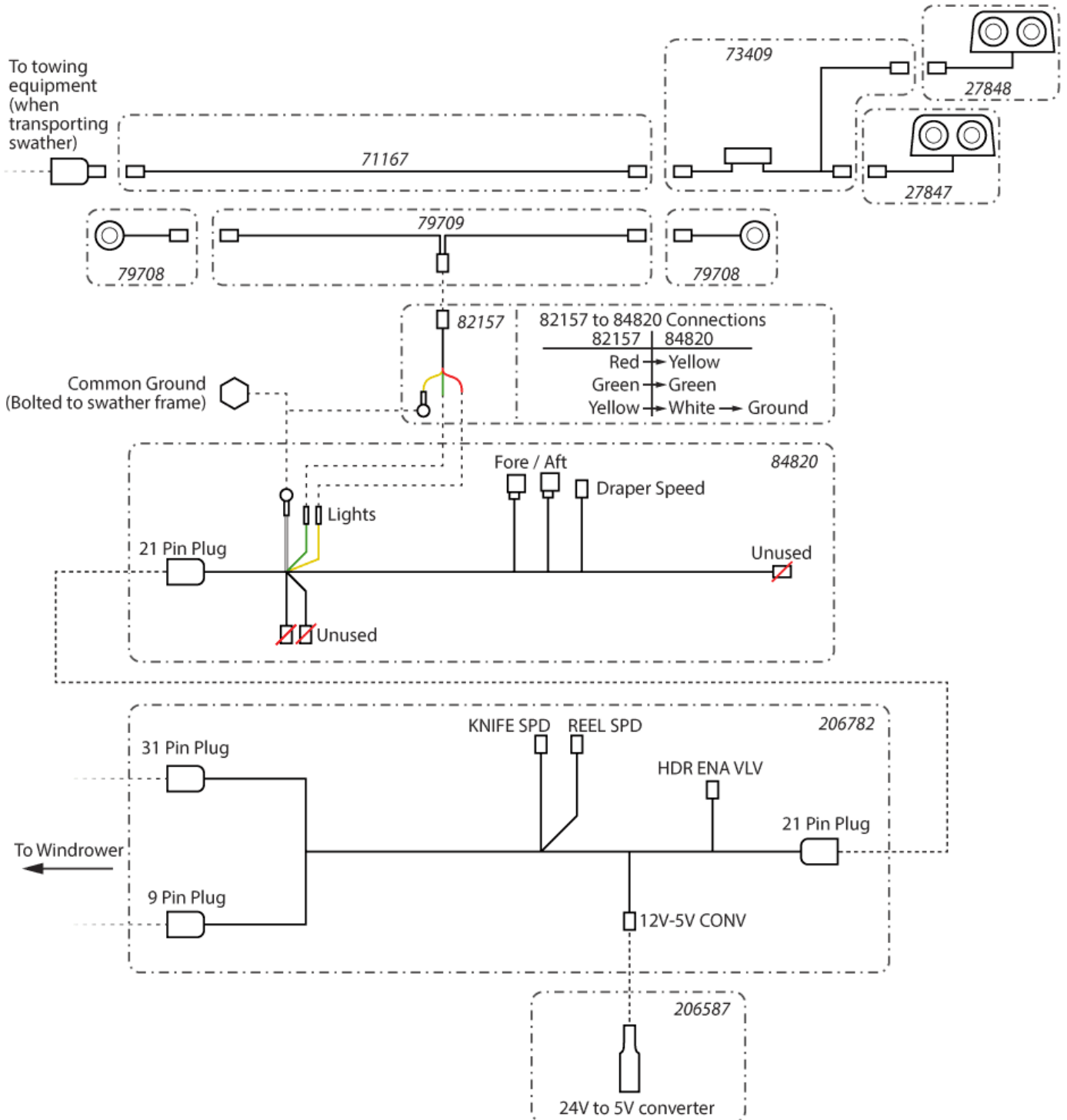

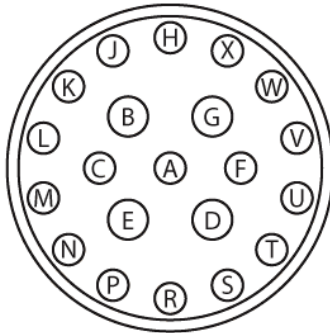
11.5.2 - Main Harness

- | | |
|-----------------|--------------------|
| A - WHITE | M - BLACK |
| B - UNUSED | N - RED |
| C - YELLOW | P - GREEN / YELLOW |
| D - UNUSED | R - ORANGE |
| E - UNUSED | S - UNUSED |
| F - GREEN | T - UNUSED |
| G - WHITE | U - UNUSED |
| H - BLUE | V - WHITE |
| J - LIGHT GREEN | W - PURPLE |
| K - LIGHT BROWN | X - PINK |
| L - BROWN | |

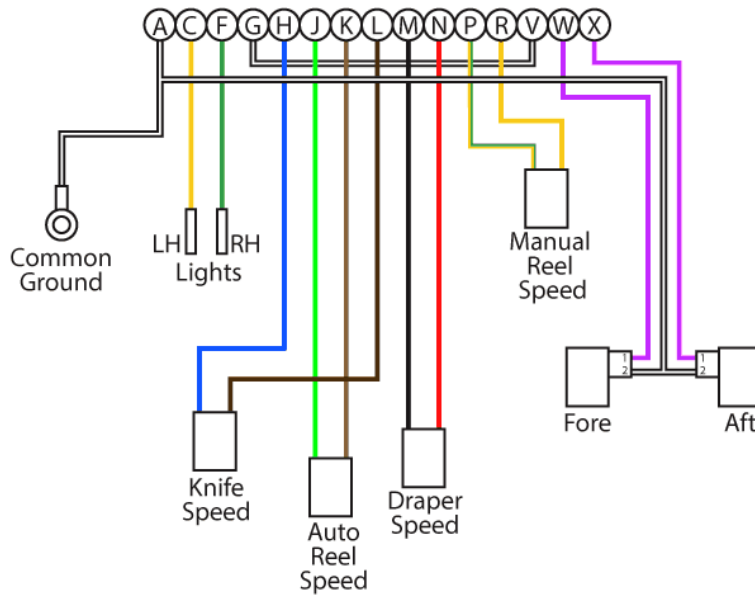

12 - Support

General Information & Sales	
E-Mail:	<i>sales@honeybee.ca</i>
Website:	<i>http://www.honeybee.ca</i>
Phone:	(306) 296-2297

Parts & Service	
Parts E-Mail:	<i>parts@honeybee.ca</i>
Service E-Mail:	<i>service@honeybee.ca</i>
Phone:	1 (855) 330-2019 (Toll free in north america)

Your Local Dealership	
E-Mail:	
Phone:	
Notes:	

Equipment manuals and service information can be found on our website:

<http://www.honeybee.ca>



Honey Bee

Harvest Faster

2020 WSA Swather Operator Manual

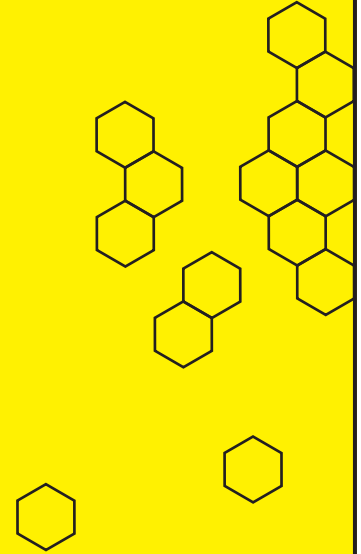

Honey Bee Manufacturing Ltd.

P.O. Box 120
Frontier SK
S0N 0W0

Tel: (306) 296-2297
Fax: (306) 296-2165

www.honeybee.ca
E-mail: info@honeybee.ca