

2024

WSC Swather

Operator Manual

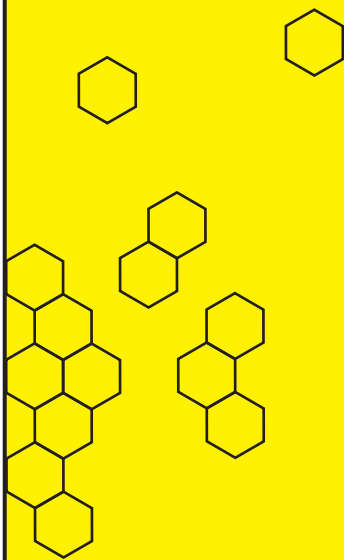

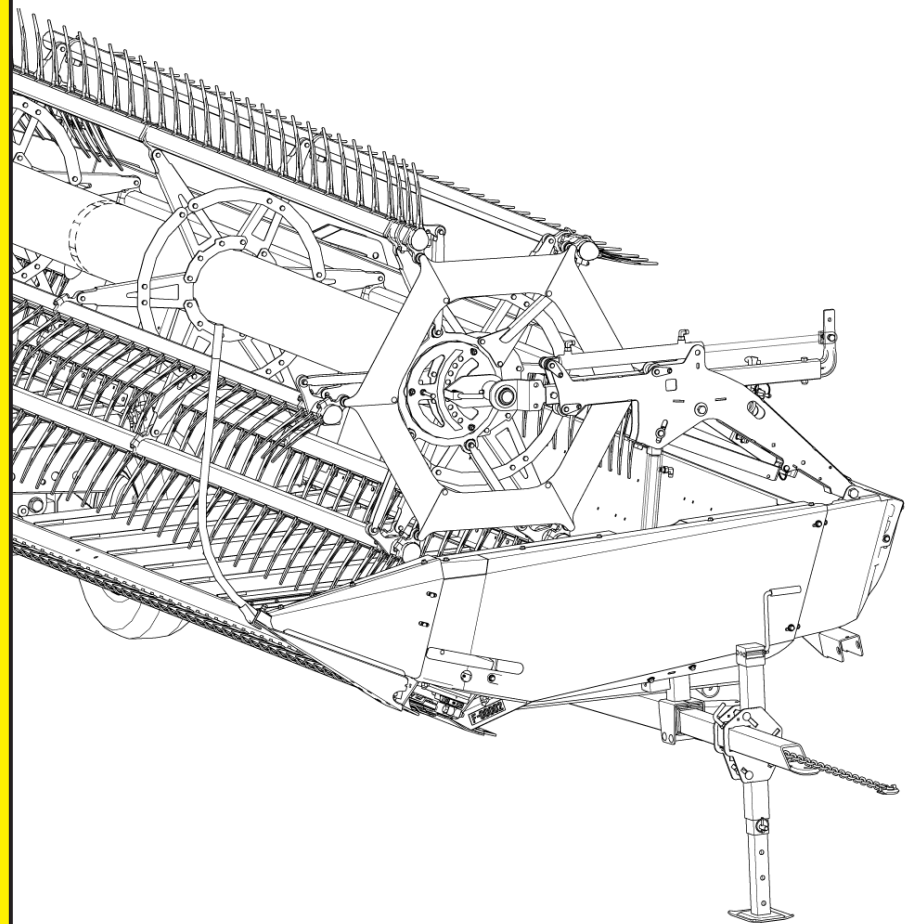

Important Notice

This manual covers the **WSC** swather only.

Review the sections of this manual regarding adjustments, settings, leveling, and table height before attempting to operate this swather.

Without proper adjustment, damage to the swather may occur.

Please wash this equipment after transporting

Honey Bee Manufacturing will not be responsible for any paint deterioration resulting from salt or harsh chemical corrosion if this equipment is not properly washed after transport. Use a mild soap solution, then rinse thoroughly.

If this equipment is stored near salted roadways through the winter months, it should be cleaned each spring.

Original Instructions

© 2023 Honey Bee Manufacturing Ltd. - All Rights Reserved

TO THE DEALER (This form must be completed and returned to Honey Bee Manufacturing Ltd. with the Warranty Registration documentation) (PLEASE PRINT)

Model: _____ Serial # _____

Check Completed By: _____ Signature: _____

Dealer name: _____ Date: _____

As soon as you receive this machine, inspect it thoroughly to be certain that it is in good order and complete. Complete a pre-delivery inspection, paying special attention to the steps listed below prior to the delivery to the customer. Indicate with a tick-mark in the left-hand column when correct.

PRE RUN-IN CHECKS

- | | |
|---|---|
| <input type="checkbox"/> Crop dividers and crop divider pipe//snub nose installed (page 24) | <input type="checkbox"/> Reel fingers clear cutter bar by approximately 2" across length of the knife (page 54) |
| <input type="checkbox"/> Quick couplers match windrower | <input type="checkbox"/> Safety and warning decals affixed securely and clearly readable. |
| <input type="checkbox"/> Reel tie-down removed (page 53) | <input type="checkbox"/> Safety guards and shields installed and secure. |
| <input type="checkbox"/> Knife drive hold down bolts torqued to 120 ft-lbs (163 Nm) (page 73) | <input type="checkbox"/> Swather lubricated. |
| <input type="checkbox"/> Reel centered in swather left to right (page 55) | <input type="checkbox"/> Optional equipment, as per sales order, is installed and operates correctly. |
| <input type="checkbox"/> Reel bat that may have been dropped for shipping reinstalled (page 53) | <input type="checkbox"/> Cab harness and control box installed. (page 25) |

MOUNTING CHECKS

- | | |
|---|---|
| <input type="checkbox"/> All adapter installation instructions completed. (page 25 - page 32) | <input type="checkbox"/> Drapers are tensioned. DO NOT OVERTIGHTEN. (page 61) |
| <input type="checkbox"/> Calibration of the windrower done successfully. (page 38) | <input type="checkbox"/> If draper deck shift is installed, ensure all stops are properly set. (page 88) |
| <input type="checkbox"/> Hydraulic oil pressures and flow rates are set. (page 70) | <input type="checkbox"/> Make sure the reel is in the correct location. (page 56) |
| <input type="checkbox"/> Set lift arms flotation pressure. (page 78) | <input type="checkbox"/> Set the cutting height for the header. (page 79) |
| <input type="checkbox"/> Set reel finger pitch to middle position as a starting point. (page 57) | <input type="checkbox"/> Walk around the header while it is running to ensure everything is running smoothly. |
| <input type="checkbox"/> Electrical systems working properly. (page 33) | <input type="checkbox"/> If possible, test in field or lot and fine-tune settings if needed. |
| <input type="checkbox"/> Hydraulic plumbing is leak-free. | <input type="checkbox"/> Ensure optional equipment as per sales order is installed and functioning. |
| <input type="checkbox"/> Drapers on all decks track evenly with adequate clearances between draper, end strut gauge wheels, and the transport hitch jack (in its storage position). (page 59 - page 62) | |

PRE-TRANSPORT CHECKS

- | | |
|--|--|
| <input type="checkbox"/> Hitch and axle attached and secure. (page 47 - page 50) | <input type="checkbox"/> All fasteners and parts secure. |
| <input type="checkbox"/> Reel lowered in the full-aft position and tied down. | <input type="checkbox"/> Wiring, hydraulic hoses tied up securely for transport. |
| <input type="checkbox"/> Wheel bolts torqued to 120 ft-lb (163 Nm). | <input type="checkbox"/> Reflectors and SMV sign in place and clean. |
| <input type="checkbox"/> Tire pressures @ 80 psi (449 KPa). | <input type="checkbox"/> Warnings and clearance lights installed and operational |
| <input type="checkbox"/> All lock pins in place and securely fastened. | |

1 - Hydraulic Readings

Use this page to record any specific hydraulics readings and/or settings done upon initial dealer inspection. See Installation and Hydraulics sections of this manual for reference.

Knife pressure gauge (when checking relief pressure): _____ PSI

Knife Drive speed (at normal working engine RPM): _____ SPM

Draper Flow Control pressure gauge (at normal working engine RPM): _____ PSI

Knife pressure gauge (at normal working engine RPM): _____ PSI

Other Settings: _____

2 - Purchase Information

Dealers Name: _____

Address: _____

Phone: _____

Purchase Date: _____

Model: _____

Serial Number: _____

Delivery Date: _____

Modification Record

Date	Modification

Honey Bee Manufacturing Limited is continually striving to improve its products. We reserve the right to make improvements or changes when it becomes practical and possible to do so, without incurring any obligation to make changes or additions to the equipment sold previously.

3 - Warranty

Honey Bee Manufacturing Ltd. (Honey Bee) warrants your new Swather to be free of defects in material and workmanship, under normal use and service. Obligations under this warranty shall extend for a period of 1 year (12 months) following the date of first use to the original purchaser and shall be limited to, at the option of Honey Bee, replacement or repair of any parts found, upon inspection by Honey Bee, to be defective.

Warranty Claims

The purchaser claiming under this warranty shall report a warranty claim to his Authorized Dealer. The dealer shall complete the claim, on the prescribed form, for inspection by an authorized company representative. Warranty claims must be made within 60 days of warranty expiration on the Honey Bee Manufacturing Ltd Claim Form (CFI).

Limitations of Liability

This warranty is expressly in lieu of all other warranties expressed or implied and all other obligations or liabilities on our part of any kind or character, including liabilities for alleged representations or negligence. We neither assume nor authorize any person to assume, on our behalf, any liability in connection with the subsequent sale of the Swather.

This warranty shall not apply to any Swather table which has been altered outside the factory in any way so as in the judgment of Honey Bee to affect its operation or reliability, or which has been subject to misuse, neglect, or accident.

Operator's Manual

The purchaser acknowledges having received training in the safe operation of the Swather and further acknowledges that Honey Bee does not assume any liability resulting from the operation of the Swather in any manner other than described in this manual.

Table of Contents

1 - Hydraulic Readings	4
2 - Purchase Information	6
3 - Warranty	8
4 - Safety	13
4.1 - Safety Terms.....	13
4.2 - Shields.....	13
4.3 - Hydraulic Safety.....	14
4.4 - Operation and Maintenance Requirements.....	15
4.5 - General Safety.....	15
4.6 - Operating Safety – Good Practices.....	16
4.7 - Maintenance Safety.....	16
4.8 - Transport Safety.....	17
4.9 - Before Transport Checklist.....	17
4.10 - During Transport Checks.....	18
4.11 - In-Field Checks.....	18
4.12 - Storage.....	18
4.13 - Safety Decal Locations.....	19
5 - Installation Instructions	23
5.1 - Mounting and Dismounting Terminology.....	23
5.2 - Windrower Draper Header Option.....	24
5.3 - Crop Divider Installation.....	24
5.4 - Pass-Through Connector Modification.....	25
5.5 - Power Unit Modifications.....	30
5.6 - Basic Windrower Controls.....	33
5.7 - Mounting the Swather to the Windrower.....	34
5.8 - Store the Transport Axle.....	36
5.9 - Store the Transport Hitch.....	37
5.9.1 - Double Swath Option.....	37
5.10 - Calibrate Power Take-Off (PTO) Draper (6-cylinder units only).....	38
5.11 - Mounting Checklist.....	39
5.12 - System Tests.....	40
5.13 - Hydraulics, Electric, and Mechanical Checklist.....	40
6 - Operation	41
6.1 - Initial Start-up.....	41
6.2 - Reel Lift Controls.....	42
6.3 - Bleeding Air Out Of Reel Lift Circuit.....	43
6.4 - Single Reel Lift Circuit.....	43
6.5 - Additional Checks.....	44
6.6 - Problems frequently encountered during start-up and break in period.....	45
6.7 - Full Dismount.....	46
6.8 - Self Storing Hitch – Transport Position.....	47
6.9 - Install Transport Axle.....	48
6.10 - Final Dismounting Steps.....	50
6.11 - Hydraulic Hose Storage.....	51





7 - Reel	52
7.1 - Reel Drive.....	52
7.2 - Reel Speed Adjustment.....	52
7.3 - Reel Position.....	53
7.3.1 - Hydraulic Fore & Aft.....	53
7.3.2 - Reel Bat Timing Position.....	53
7.3.3 - Solid Reel Hydraulic Circuit.....	53
7.4 - Reel Arm Leveling and Height Adjustment.....	54
7.4.1 - Reel Height Adjustment.....	54
7.5 - Reel Centering.....	55
7.6 - Placement of the Reel on the Swather.....	56
7.7 - Reel Position in Down Crops.....	56
7.8 - Reel Position in Standing Crops.....	57
7.9 - Reel Tine Pitch Adjustment.....	57
7.10 - Lubrication – Reel Shaft Bearings.....	58
7.11 - Check Points Before Operation:.....	58
8 - Draper and Decks	59
8.1 - Lining Up the Drive Roller.....	59
8.2 - Draper Installation.....	60
8.3 - Tensioning.....	61
8.3.1 - Spring Tension Indicator.....	61
8.4 - Tracking.....	62
8.4.1 - Drive Roller Tracking Adjustment.....	62
8.4.2 - Idler Roller Tracking Adjustment.....	63
8.5 - Draper Speed.....	63
8.5.1 - Additional Draper Speed.....	63
8.6 - Draper Splicing.....	64
8.7 - Drive Roller Removal.....	66
8.8 - Removing Draper Motor.....	66
8.9 - Replace Bearings on Drive Roller.....	67
8.10 - Installing Draper Motor.....	67
8.11 - Idler Roller Removal.....	68
8.12 - Replace Bearings on Idler Rollers.....	68
8.13 - Draper Deck Maintenance:.....	69
8.14 - Draper & Reel Maximum Speed Adjustment.....	70
9 - Cutting System	71
9.1 - Knife Speed.....	71
9.2 - Removing the Knife.....	71
9.3 - Guards.....	72
9.4 - Sickle Sections.....	72
9.5 - Knife Drive/Knife Head.....	73
9.6 - Connector Bar.....	74
9.7 - Overlap Kit.....	75
9.8 - Repair Broken Knife Back.....	76
9.9 - Knife Speed Sensor.....	76
9.10 - Monitoring Knife Speed.....	76
10 - Leveling	77
10.1 - Forward Angle Adjustment – Hydraulic Tilt Cylinder.....	77
10.2 - Table Angle (Tilt).....	77
10.3 - Adjusting Independent Table Floatation.....	78
10.4 - Setting the Cut Height.....	79

11 - Hydraulics	80
11.1 - Manifold Block Cartridge Locations.....	80
11.2 - Flow Controls.....	80
11.3 - Hydraulic Connection Points.....	81
11.4 - Operating Pressure - Knife Circuit.....	81
11.5 - Checking or Adjusting Knife Relief Pressure.....	82
11.6 - Knife Drive Speed Adjustment.....	83
11.7 - Draper and Reel Flow Controls.....	84
11.8 - Return Line Filter.....	84
12 - Optional Equipment	85
12.1 - Caster Gauge Wheels.....	85
12.2 - Gauge Wheel Height Adjustment.....	85
12.3 - End Strut Gauge Wheels.....	86
12.4 - Cross Auger.....	87
12.5 - Double Swath Option – 30ft and 36ft Tables Only.....	88
12.6 - Increasing Center Swath Opening.....	89
12.7 - Hay Guard / Short Crop Guard.....	95
13 - Lubrication & Maintenance	96
14 - Troubleshooting	97
15 - Lighting	102
15.1 - Transport Lights.....	102
15.2 - Warning Flashers.....	102
15.3 - Wiring.....	103
15.4 - Transport Lights.....	104
15.5 - Warning Flashers.....	104
16 - Appendix	105
16.1 - Hydraulic Fitting Naming Standards.....	105
16.2 - Electrical Schematics & Charts.....	106
16.2.1 - Swather Table Electrical Schematic.....	106
16.2.2 - Common 21 Pin Plug Features.....	107
16.2.3 - Adapter Wiring Schematic.....	108
16.3 - Hydraulic System Schematics.....	109
16.3.1 - Hydraulic System Schematic Symbols.....	109
16.3.2 - Double Swath - Double Knife - Solid Reel - System Hydraulic Schematic.....	110
16.3.3 - Single Swath - Double Knife - Solid Reel - System Hydraulic Schematic.....	111
16.4 - Dimensions.....	112
16.5 - Windrow Type.....	113
16.5.1 - Windrow Formations.....	113
16.5.2 - Ground Speed.....	113
16.5.3 - Stubble Height.....	113
16.6 - Specifications/Features.....	114
16.6.1 - Weights.....	114
16.6.2 - Technical Specifications.....	115
16.6.3 - Options.....	115
16.6.4 - Included in Standard Swather.....	116
16.7 - Bolt Torque.....	116
16.8 - Hydraulic Fitting Torque.....	117
16.9 - Tightening O-ring Fittings.....	118
16.10 - Compatible Replacement Hydraulic Filters.....	119

4 - Safety

In this manual, the safety conventions used are as follows:

4.1 - Safety Terms

	Indicates an imminently hazardous situation that, if not avoided, will result in death or serious injury. This signal word is to be limited to the most extreme situations.
	Indicates a potentially hazardous situation that, if not avoided, could result in death or serious injury, and includes hazards that are exposed when guards are removed. It may also be used to alert against unsafe practices.
	Indicates a potentially hazardous situation that, if not avoided, may result in minor or moderate injury. It may also be used to alert against unsafe practices.
	Warns of potential damage to the machine if procedures are not followed.
	Provides instructions to help you avoid unnecessary strain on, or possible damage to the machine.

4.2 - Shields

Shields are provided to protect you from injury. Make sure they are in place and secured before starting the machine.

Names given here for parts of the swather are those in use at the time of design.

4.3 - Hydraulic Safety



This machine is powered and run by hydraulic oil under high pressure. Caution must be taken around the machine because high pressure hydraulic fluid can penetrate the skin causing serious injury and possibly death. When looking for a hydraulic leak, always hold a piece of cardboard up to the suspected area. Never use your unprotected hands to locate a leak. Always wear eye protection, gloves and long sleeve clothing when working near hydraulics. Small leaks can be completely invisible.

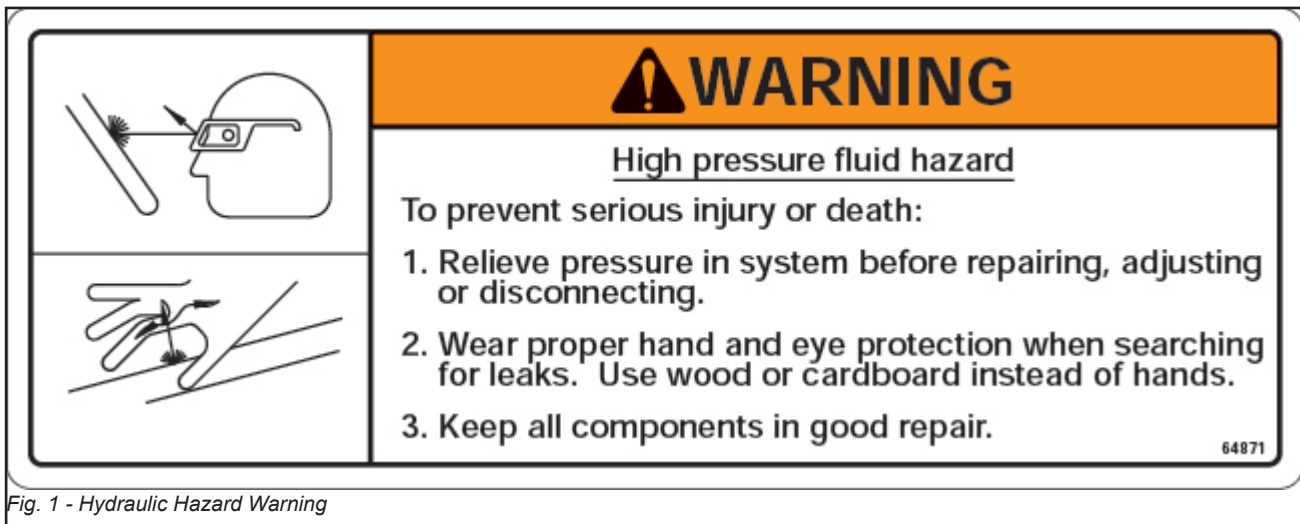

WARNING

High pressure fluid hazard

To prevent serious injury or death:

1. Relieve pressure in system before repairing, adjusting or disconnecting.
2. Wear proper hand and eye protection when searching for leaks. Use wood or cardboard instead of hands.
3. Keep all components in good repair.

64871

Fig. 1 - Hydraulic Hazard Warning

You can reduce this hazard by relieving the system pressure before disconnecting hydraulic lines. Once finished, tighten all connections to specifications before re-applying pressure.



If a hydraulic-related accident occurs, see a doctor immediately. Any hydraulic fluid injected into the body must be surgically removed within a few hours or gangrene may result. Doctors unfamiliar with this type of injury should reference a knowledgeable medical source.

4.4 - Operation and Maintenance Requirements

You are responsible for the safe operation and maintenance of your Honey Bee Swather. You must ensure that you and anyone else, who is going to operate, maintain or work around the swather be familiar with the operating and maintenance procedures and related safety information contained in this manual.

Remember you are the key to safety. Good safety practices not only protect you but also the people around you. Make these practices a working part of your safety program. Most accidents can be prevented. Do not risk injury or death by ignoring good safety practices.

Operating instructions for this swather should be reviewed by each operator at least once a year per OSHA regulations 1928.57. The meaning of each decal should be understood, and their locations should be known prior to operating the swather.

4.5 - General Safety

Maintain moving parts, hydraulics and motors clear of chaff and straw to prevent the possibility of fire.

Carry a multipurpose fire extinguisher in the windrower and know how to use it. Check the extinguisher regularly and keep it fully charged.

Provide a first aid kit in the cab for emergencies and know how to use it.

Do not wear loose clothing or jewelry around moving parts.

Wear appropriate protective gear. This list includes but is not limited to:

- A hard hat
- Protective shoes with slip-resistant soles
- Protective glasses or goggles
- Leather gloves
- Hearing protection
- Respirator or filter mask

Do not allow any one to ride on the swather while it or the windrower is in motion.

Make certain that the park brake is engaged, and the windrower is in neutral before starting the engine.

Clear the area of bystanders, especially small children before starting the windrower.

Do not allow anyone to operate the swather who has not been instructed in how to operate the machine.

All operators should familiarize themselves with the SAFETY section in the windrower Operators Manual.

Some pictures or illustrations in this manual may not show protective shields in place. This is done in order to make important components visible. Make certain that all protective shields are secured in place before operating the machine.

4.6 - Operating Safety – Good Practices

STOP the windrower, engage the parking brake, place the windrower in neutral, remove the key, and wait until all moving parts stop before leaving the cab.

Either lower both the table and the reel, or raise the swather to its full height and set the platform lock before servicing the swather. If working under reel, set the reel cylinder locks. A loss of hydraulic pressure could cause the swather and reel to lower unexpectedly.

NEVER operate machinery while tired, sick or otherwise impaired.

Do not operate the swather in crowded or confined areas.



Do not stand between the windrower and the swather while raising or lowering the swather.

4.7 - Maintenance Safety

Before undertaking any maintenance, engage the park brake, either lower the reel and swather, or raise and lock the swather using the platform lock and shut off the engine of the windrower. Make sure there is no pressure being supplied to the hydraulic lines.

Hydraulic leaks can penetrate the skin causing serious injuries. Small leaks can be invisible and are the most dangerous. Use some kind of object, such as cardboard, to find the leak -- DO NOT USE YOUR HAND.

Ensure that all the pressure is released from the hydraulic lines before starting a repair. Replace or repair damaged hoses immediately.

Care should be taken when maintaining the knife. Sickle sections are very sharp and can easily cause severe injury. Use heavy leather or canvas gloves when working with the knife. Always ensure everyone is well clear before moving the knife, manually or under power.

4.8 - Transport Safety

1. Transport the swather with the SMV (Slow Moving Vehicle) sign displayed on the rear of the swather and use your hazard lights if the law permits. Check local road laws before transporting.
2. When transporting the swather on roads, always be aware of the width of the swather.
3. For long distance transporting, completely install the full transport assembly. (see dismount section).
4. Do not transport the machine at night, at dawn, or at dusk.
5. Ensure hitch is firmly attached and secured with hitch pins before moving.
6. Attach the hitch safety chain before moving.
7. Do not exceed 32 kph (20 mph) during transport.
8. Ensure you display the Slow Moving Vehicle sign during transport on roadways.

4.9 - Before Transport Checklist

Do a complete walk-around and check to be sure there are no loose parts or components.

Check:

- All reel mounting, reel drive and adapter assembly bolts to be sure no bolts/nuts are loose.
- Wheel bolts to make sure they are tight.
- Transport tire pressure. Recommended pressure is 80 psi (552 kPa)
- Spindle and hitch lock pins to make sure they are in place and securely fastened.

Inspect all hoses. Ensure they are secured so they will not pinch or drag during transport.

Ensure hitch tongue and safety chain are fastened securely to the swather and to the transporting vehicle.

Make sure that all transport lights are properly connected and in their transport position.

4.10 - During Transport Checks

Stop after the first 5 to 10 kilometers (2 to 6 miles) and check to make sure the wheel bolts are tight and the wheel hubs are not hot. Make periodic checks every 50 to 60 km (30 -40 miles) if towing the swather long distances.

Check the hitch bolt and safety chain periodically to make sure they are secure.

4.11 - In-Field Checks

The Installation and Operation sections of your operator's manual cover the adjustments which may be required on your swather. Read these sections carefully before using your machine. Make the necessary adjustments before operating your swather, and check these adjustments periodically as required.

4.12 - Storage

Store the swather on firm ground away from areas of human activity. If the storage location exposes the swather to road salt during the winter months, thoroughly wash the swather in spring time. It is recommended to rotate the drapers so that the seam of the join is located underneath the table. This will improve drainage, thus reducing the possibility of ice buildup damaging the draper material.

4.13 - Safety Decal Locations

The following safety decals have been placed on your machine in the areas indicated. They are intended for your safety, and the safety of those working with you. Please take this manual, walk around your machine and familiarize yourself with the locations and content of these warning signs and labels. Review this information, and the operating instructions in this manual with your machine operators. Keep decals legible. If they are not, we suggest you obtain replacements from your Honey Bee dealer.

Keep them clean.

Know the location and meaning of all decals. Cross reference the numbers on the diagram below with the chart on the following pages to help identify the labels.

For continued safe operation of this machinery, it is recommended that you replace damaged safety decals immediately. You may purchase replacement decals from your dealer.

The following illustration indicates the location of all labels on your swather. Match the number indicated in this diagram to the numbered illustrations provided.

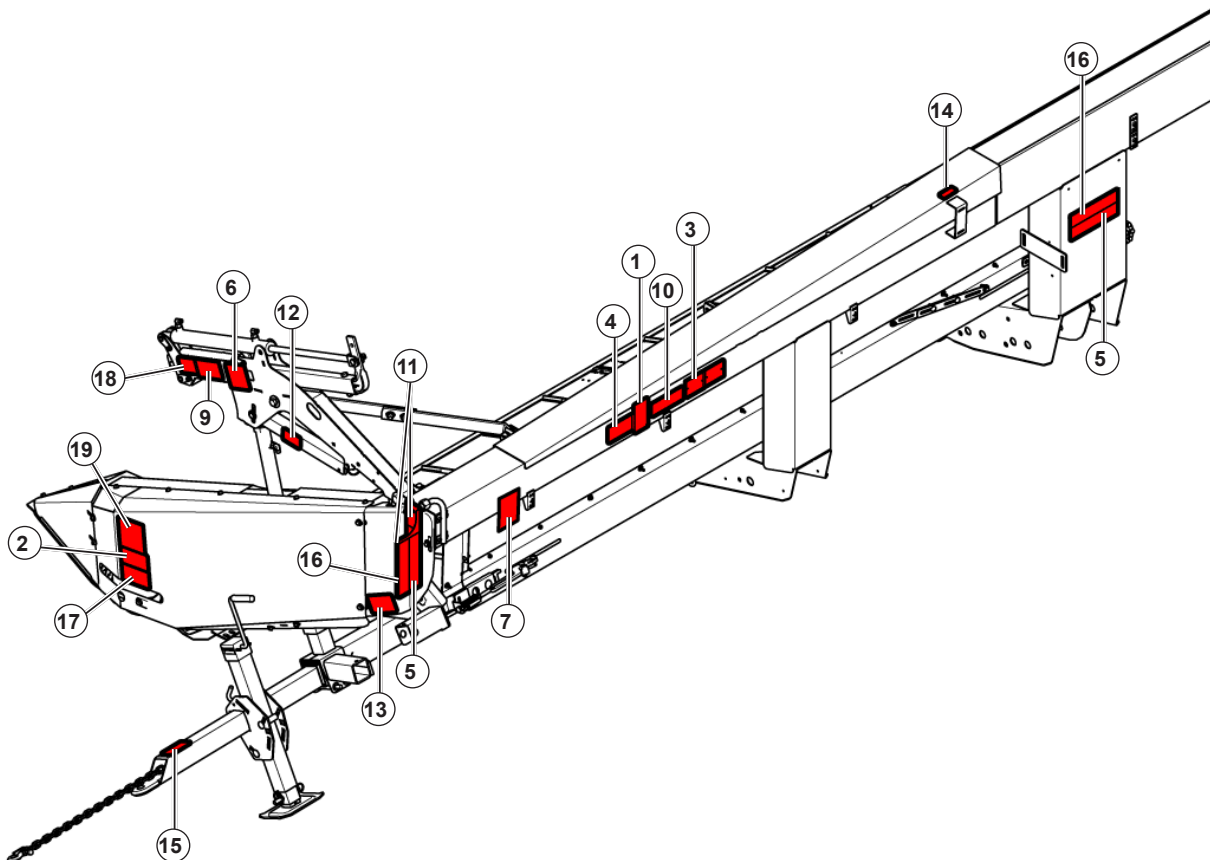

Fig. 2 Decal Location - Left End

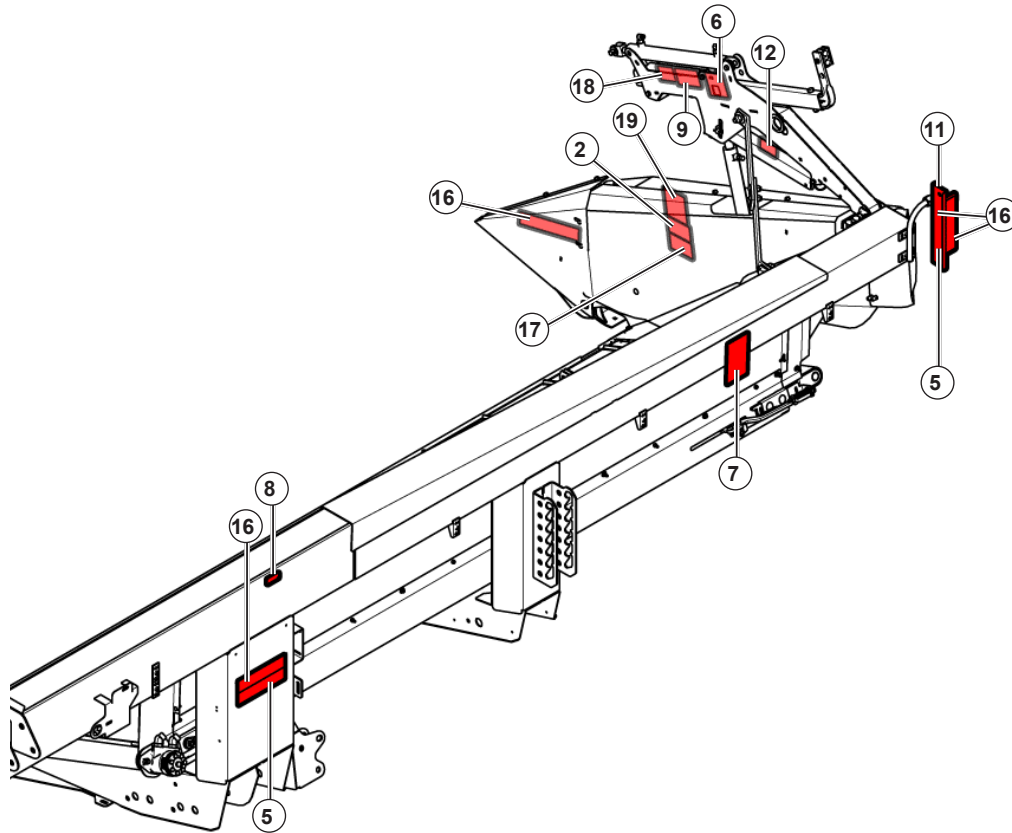

Fig. 3 Decal Location - Right End

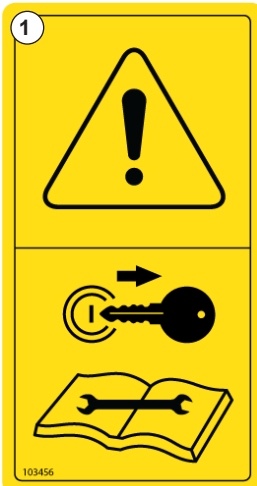

Fig. 4 Decal - Read the manual before servicing



Fig. 5 Decal - Keep hands away from shield opening

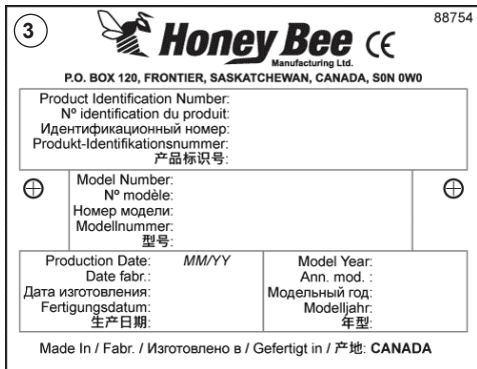

Fig. 6 Serial number plate



Fig. 7 Decal - High pressure fluid warning - Read manual for more details



Fig. 8 Decal - Red/orange retroreflector

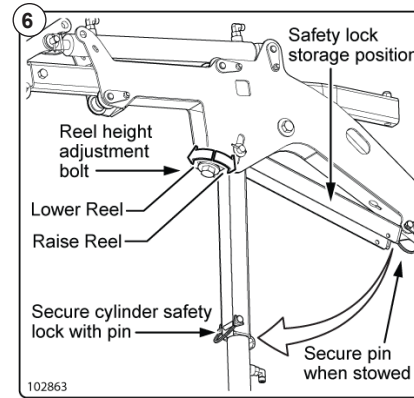

Fig. 9 Decal - Reel arm instructions

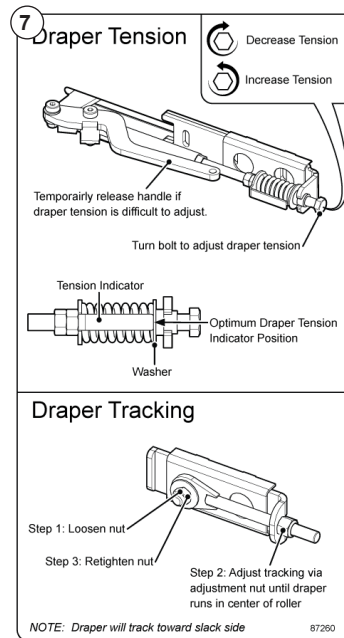

Fig. 10 Decal - Draper adjustment instructions



Fig. 11 Decal - Reel speed gauge label



Fig. 12 Decal - Rotating parts warning, keep your distance.

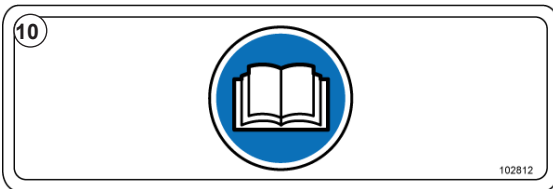

Fig. 13 Decal - Operator manual location label



Fig. 14 Decal - Yellow reflector

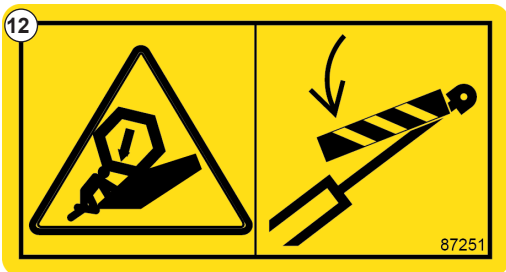

Fig. 15 Decal - Use reel arm lock before servicing

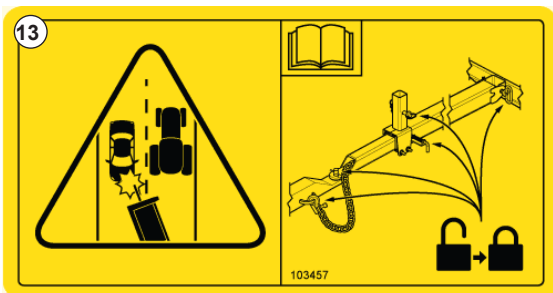

Fig. 17 Decal - Secure transport hitch before transporting



Fig. 20 Decal - Draper pressure gauge label



Fig. 16 Decal - Maximum transport speed



Fig. 18 Decal - Red reflector



Fig. 19 Decal - Warning sharp sections

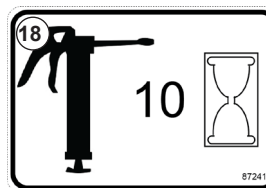

Fig. 21 Decal - grease every 10 hours

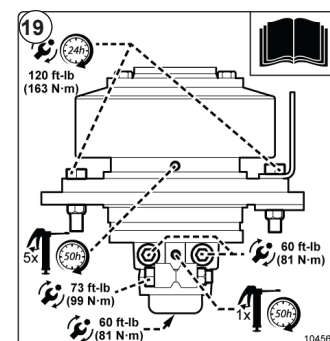

Fig. 22 Decal - Knife drive maintenance

5 - Installation Instructions

This information is designed for first-time installation, but will be valuable every time you are re-mounting the swather to the windrower. It is suggested that you follow the instructions in the order that they are given to avoid difficulties. Use the check lists at the end of this section to ensure that the swather is mounted properly and ready for the field.

5.1 - Mounting and Dismounting Terminology

Windrower:	Front	Lift arm end of the windrower
	Back or Rear	Engine end of the windrower
	Right and Left	As seen when sitting in the driver's seat facing the swather.

Swather Table:	Front	Cutter bar side
	Back or Inside	Lift arm mount side
	Right and Left	As seen when sitting in the driver's seat facing the swather when it is mounted on the windrower.

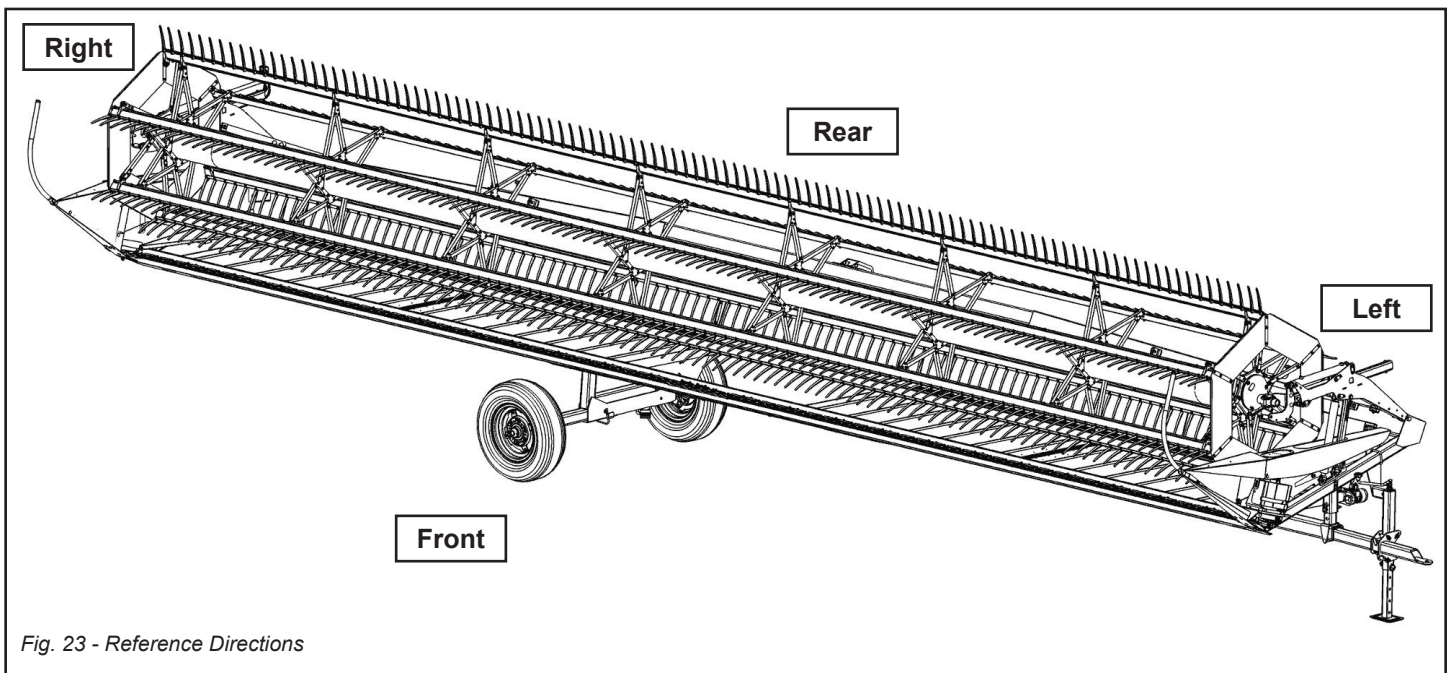

Fig. 23 - Reference Directions

5.2 - Windrower Draper Header Option

Ensure your windrower's software system is compatible with the honeybee swather. The UCM software can be verified by selecting Diagnostics>CAN, where the Software Version must be V22.6.0.0 or later.

Next, select Diagnostics>Version and verify that the Windrower software is V36.1.0.0 or later. Refer to your Windrower Operator Manual for instructions on updating your software.

If the software is up to date, You should be able to navigate to Toolbox>Header and see three options: Sickle, Disc, and Draper. The Draper option is required to operate your Honey Bee swather. If the draper option is not listed, you will need to contact your dealer to have it enabled. You should also see an option to calibrate your Honey Bee Draper in the Calibration settings. Calibration instructions are covered in section 5.10 on page 38

5.3 - Crop Divider Installation

1. Park the Swather on flat, hard, and level ground. Support the hitch end of the unit by extending the hitch jack until the swather is sitting level.
2. Install the crop dividers, and crop divider pipes (or stub nose) to the ends of the table. The crop divider and pipes are not installed at the factory for shipping purposes. Once installed, operators should be aware of the assembled width of the swather, and should check local regulations before transporting on public roadways.
3. The bottom of the crop divider is secured to the swather by 4-1/2" x 1/2" carriage bolt and a 1/2" C/Lock nut. The top of the crop divider is secured to the swather with four 5/16" x 1" Flange bolts and four 5/16" flat washers.

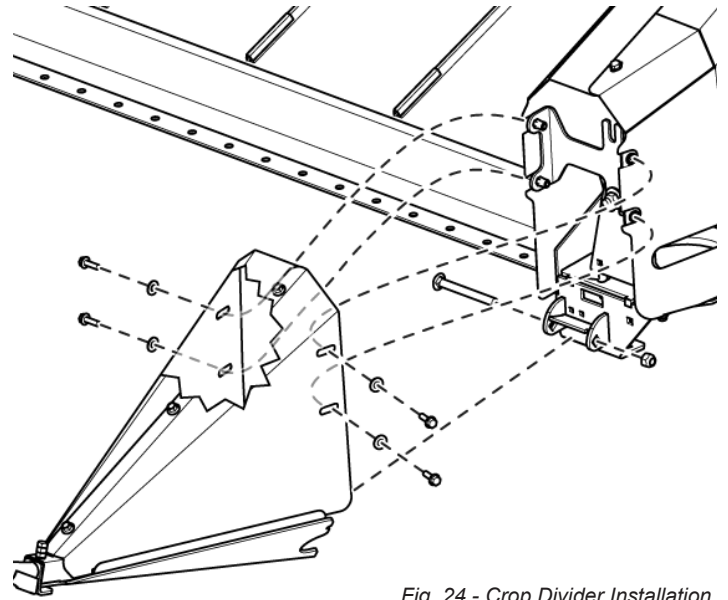

Fig. 24 - Crop Divider Installation

4. When properly positioned, the crop divider overlaps the outside of the crop deflector to provide a smooth transition for the crop.
5. Insert the crop divider pipe (or stub nose) into the nose of the crop divider. Secure with a 3/8" x 1 1/2" bolt and lock nut.

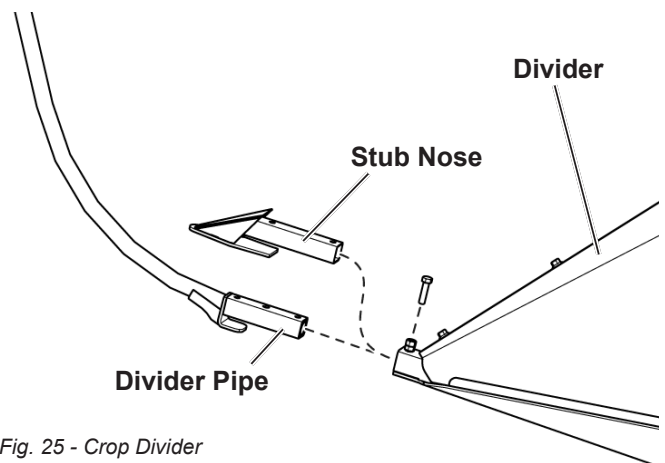

Fig. 25 - Crop Divider



NOTE!

The divider is designed to be adjusted in order to run without trampling the crop. This will provide good crop separation, and will help prevent crop plugging in the corners. The crop divider pipe is intended to be used when cutting off the ground, and the stub nose is to be used when cutting on the ground.

5.4 - Pass-Through Connector Modification

1. Locate the outer pass-through connector on the rear-left outer wall of the cab (located inside the access hatch).

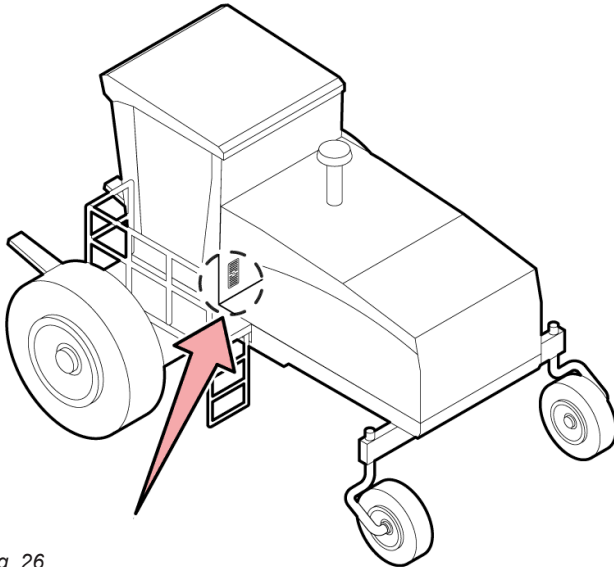

Fig. 26

2. Remove the outer connector using a socket wrench.

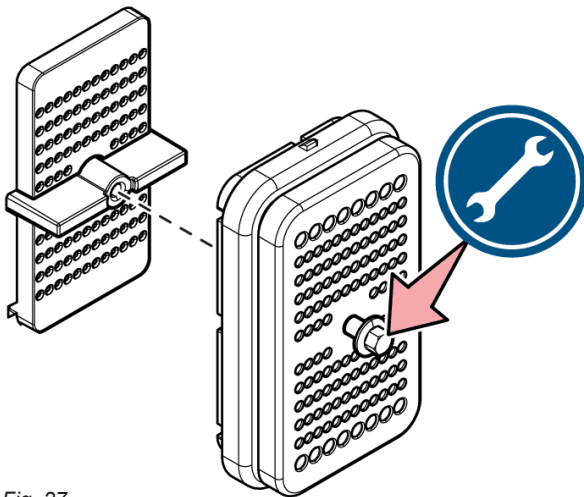

Fig. 27

3. Remove the two wedge locks from the rear of the connector as shown below.

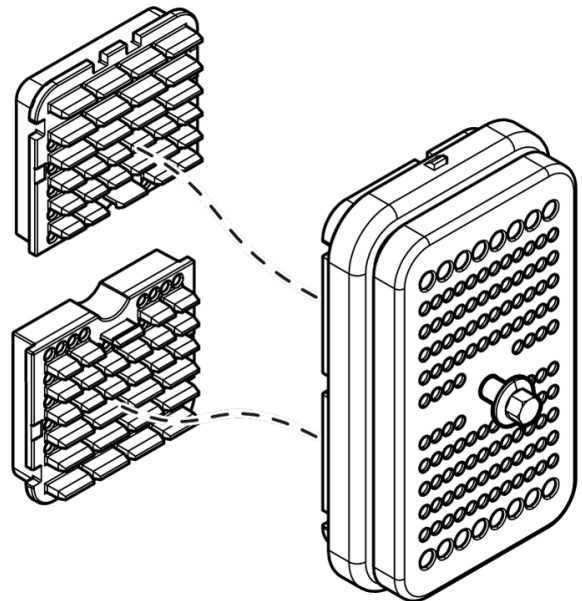

Fig. 28

- Secure the harness connector to the external pass-through connector. Take note of the plug style used on the harness connector shown below.

The connector on the end of each wire should be inserted into its corresponding hole until an audible 'click' is heard.

Refer to Fig. 9 for details on where the wires should be inserted.

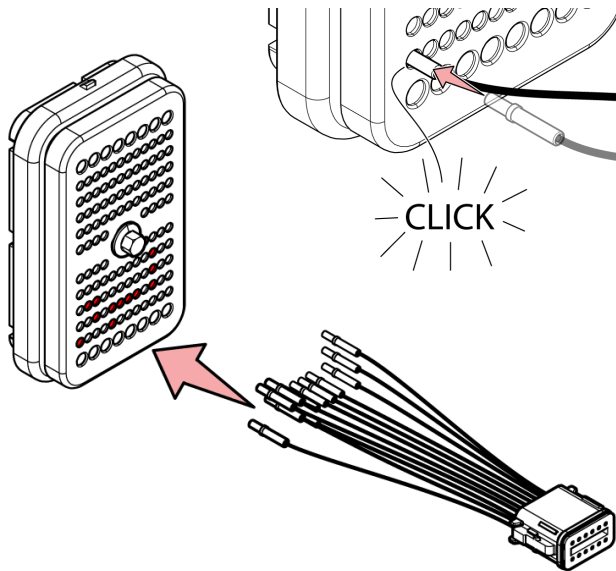

Fig. 29

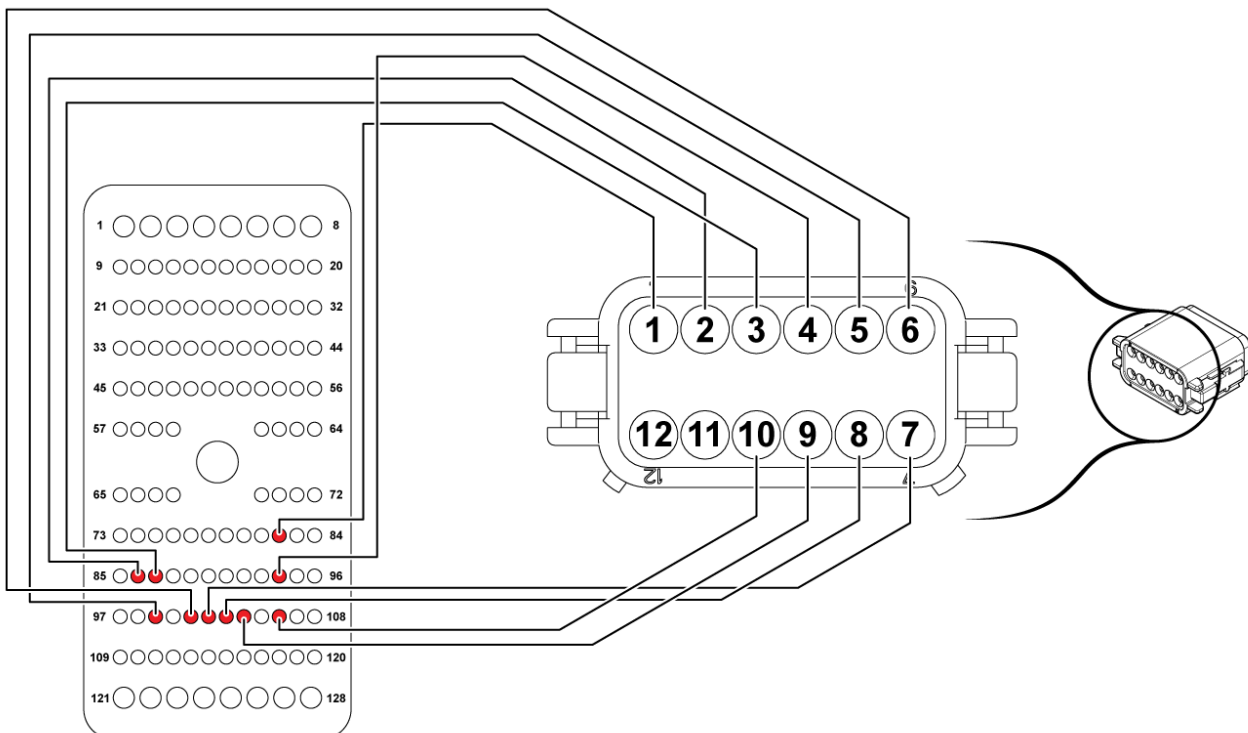

Fig. 30

5. Locate the inner pass-through connector on the rear-left inner wall of the cab (located inside the cab, under the instructor's seat).

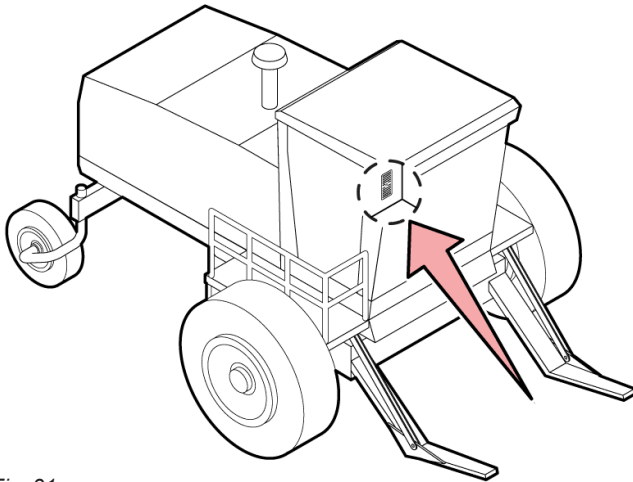

Fig. 31

6. Remove the inner connector, then remove both wedge locks.

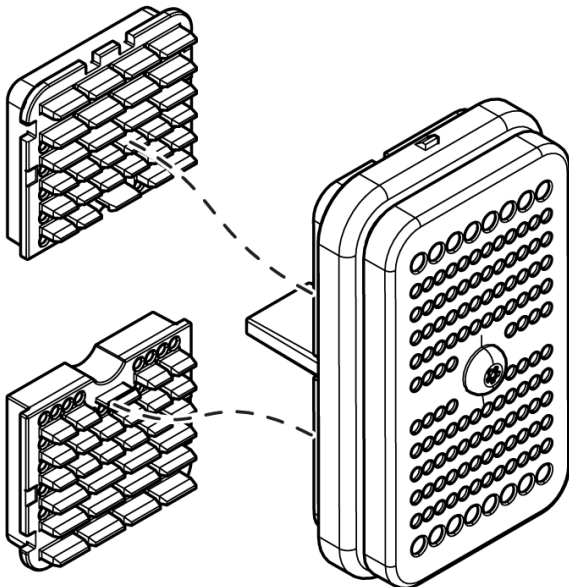

Fig. 32

7. Secure the harness connector to the internal pass-through connector. Take note of the plug style used on the harness connector shown below.

The connector on the end of each wire should be inserted into its corresponding hole until an audible 'click' is heard.

Refer to figure Fig. 13 for details on where the wires should be inserted.

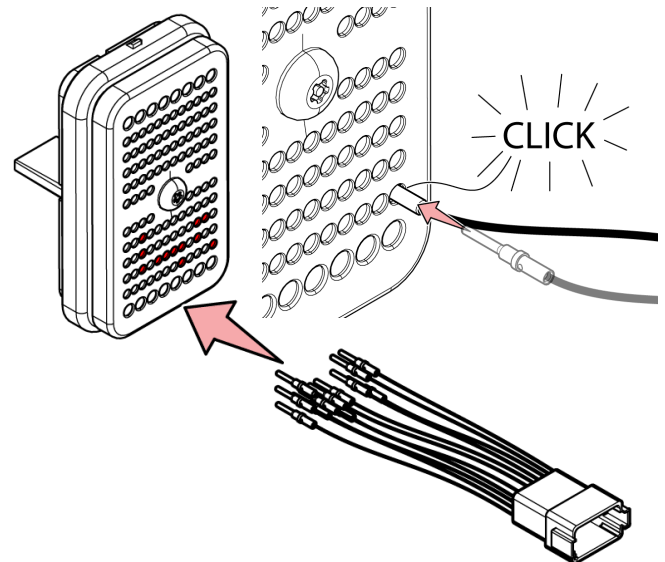

Fig. 33

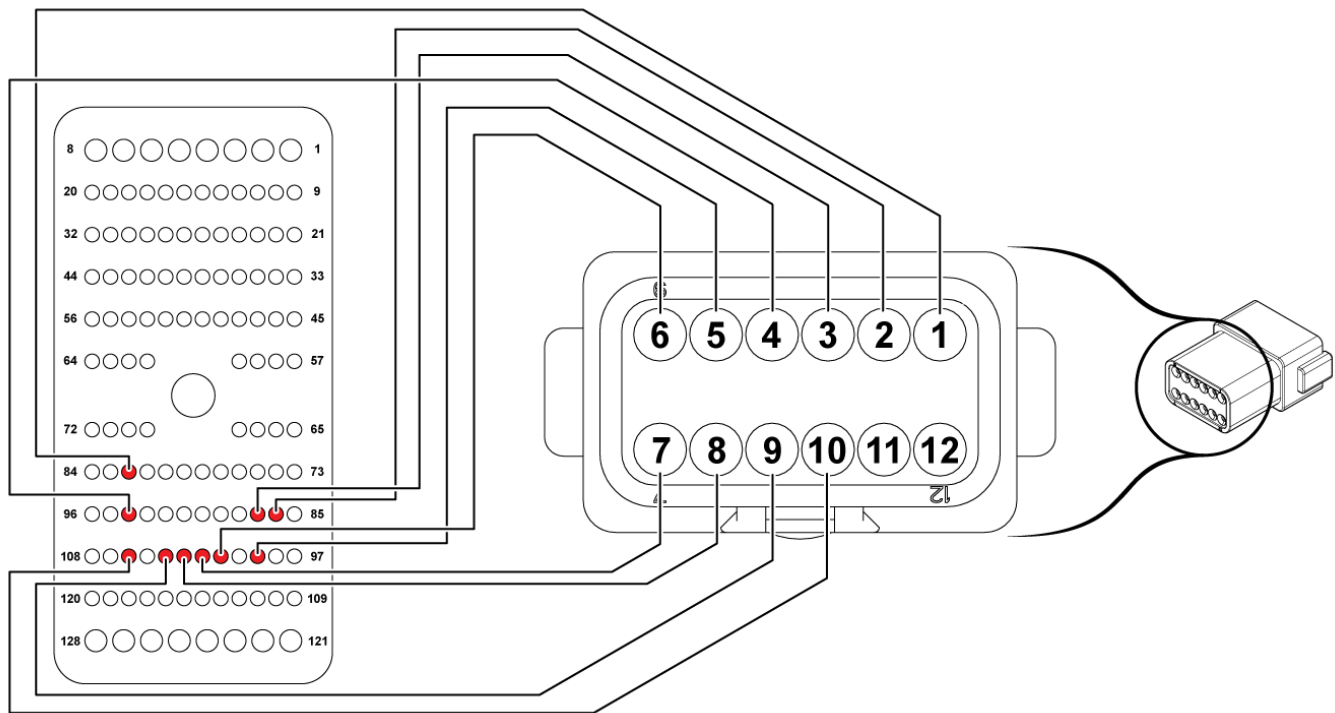

Fig. 34

8. Reinstall the wedge locks on both of the pass-through connectors, taking care to ensure the pins are aligned with the openings in the wedge blocks.

Reinstall the connectors in their original locations on the windrower cab wall.

- Install the switch box inside the power unit cab. The switch box is plugged into the 12V socket and the pass-through connector installed in an earlier step.

The switch box mounting arm is secured to the display mounting arm as shown below.

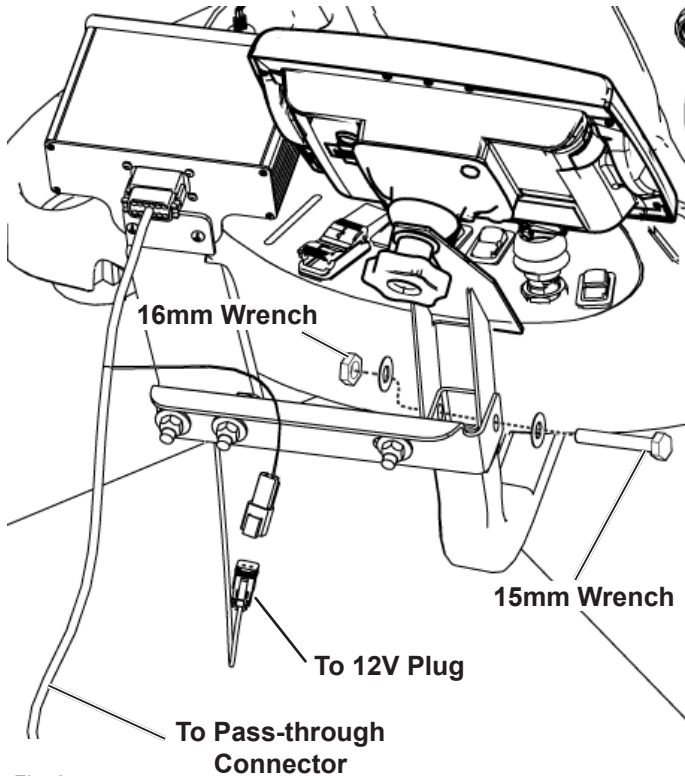

Fig. 35

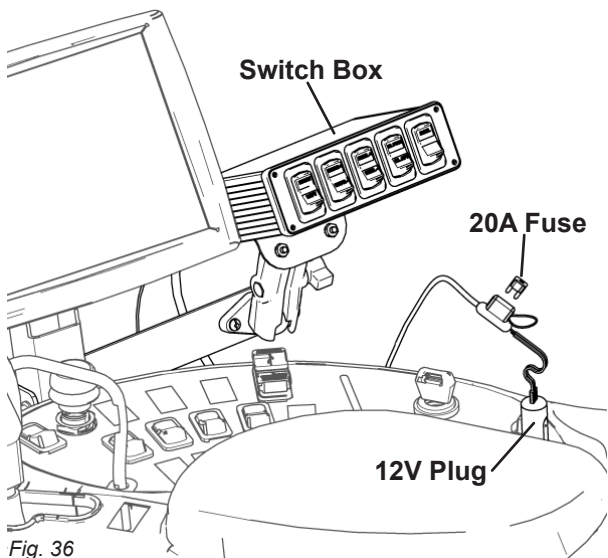
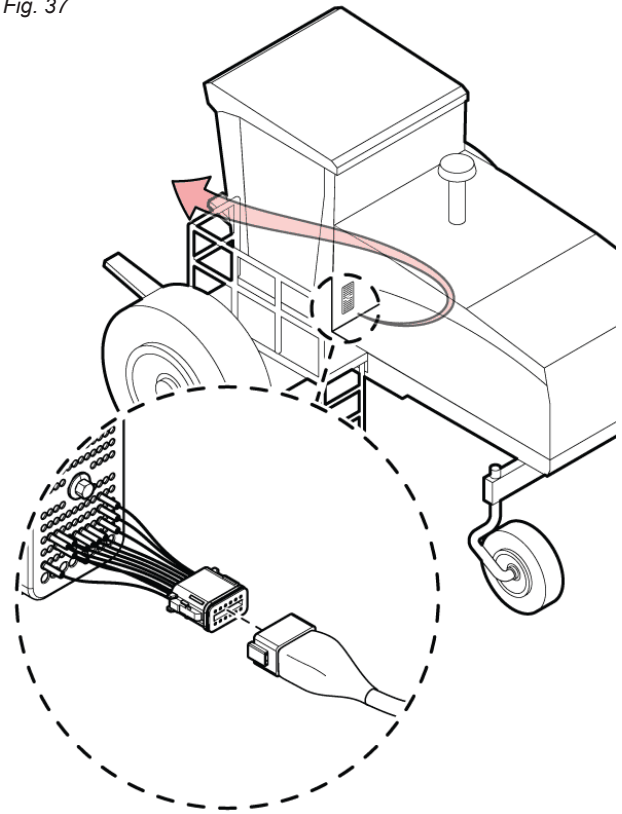

Fig. 36

- Secure the external harness to the connector on the outside of the cab as shown below. Route the harness under the cab between the fuel tanks. Secure the harness along its length using zip-ties.

Fig. 37



- Secure the connectors on the end of the harness as shown below.

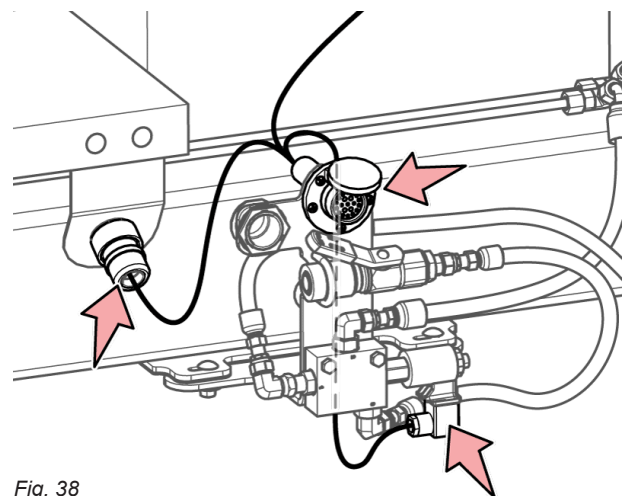

Fig. 38

5.5 - Power Unit Modifications

12. Secure the bracket to the front of the power unit cab as shown below. Use the two 3/8" x 1-1/4" UNC carriage bolts and nuts provided in shipping box, do not re-use the original bolts.

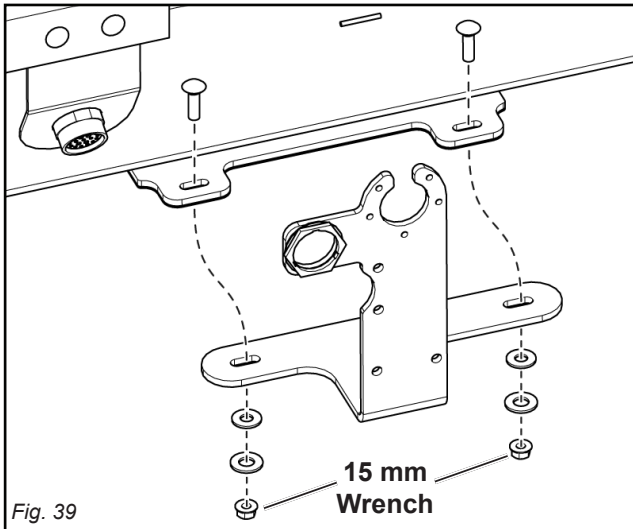
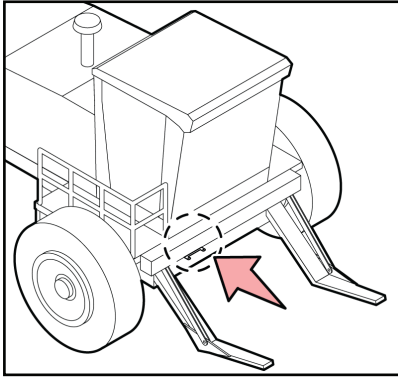

Fig. 39

13. Secure the 21 pin plug from the external harness and dust cap to the bracket using #10-32 x 1" machine screws, #10-32 nuts and #10 star lock washers (5 ea.) as shown below. Add the provided O-ring (27449) under the dust cap.

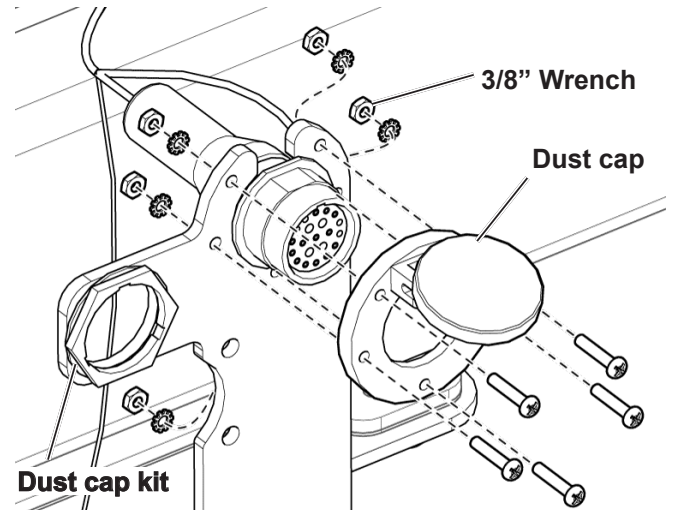

Fig. 40

14. Plug in the other 21 pin plug from the external harness to the location shown below.

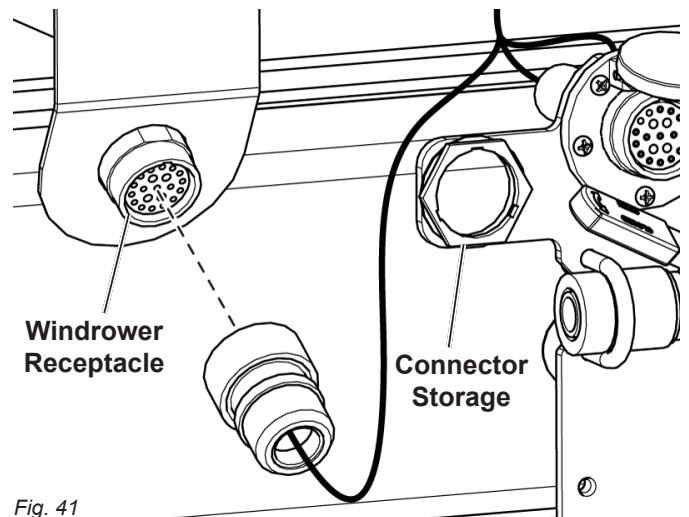

Fig. 41

15. Secure the quick coupler to the bracket using the 5/16" x 1-13/32" x 2-3/16" U-bolt, 3/8" fender washer, 5/16" flat washer, and two 5/16" C/lock nuts as shown below. Ensure the dust plug is secured as shown.

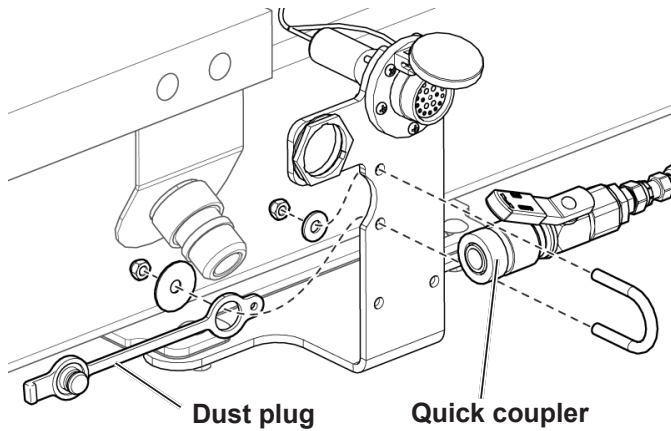

Fig. 42

16. Pre-assemble the manifold block with the supplied fittings as shown below.

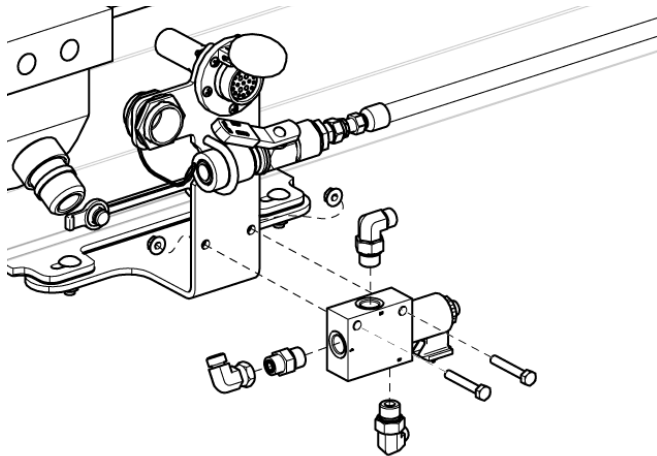

Fig. 44

17. Install the manifold block onto the bracket using two 5/16" x 2" Bolts and two 5/16" F/lock nuts as shown below

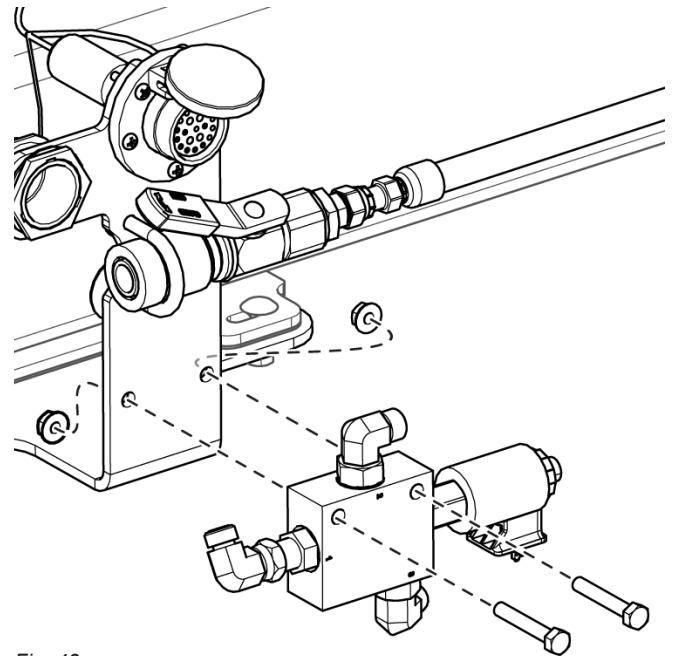

Fig. 43

18. Secure the hirschmann plug and hydraulic hoses as shown below.

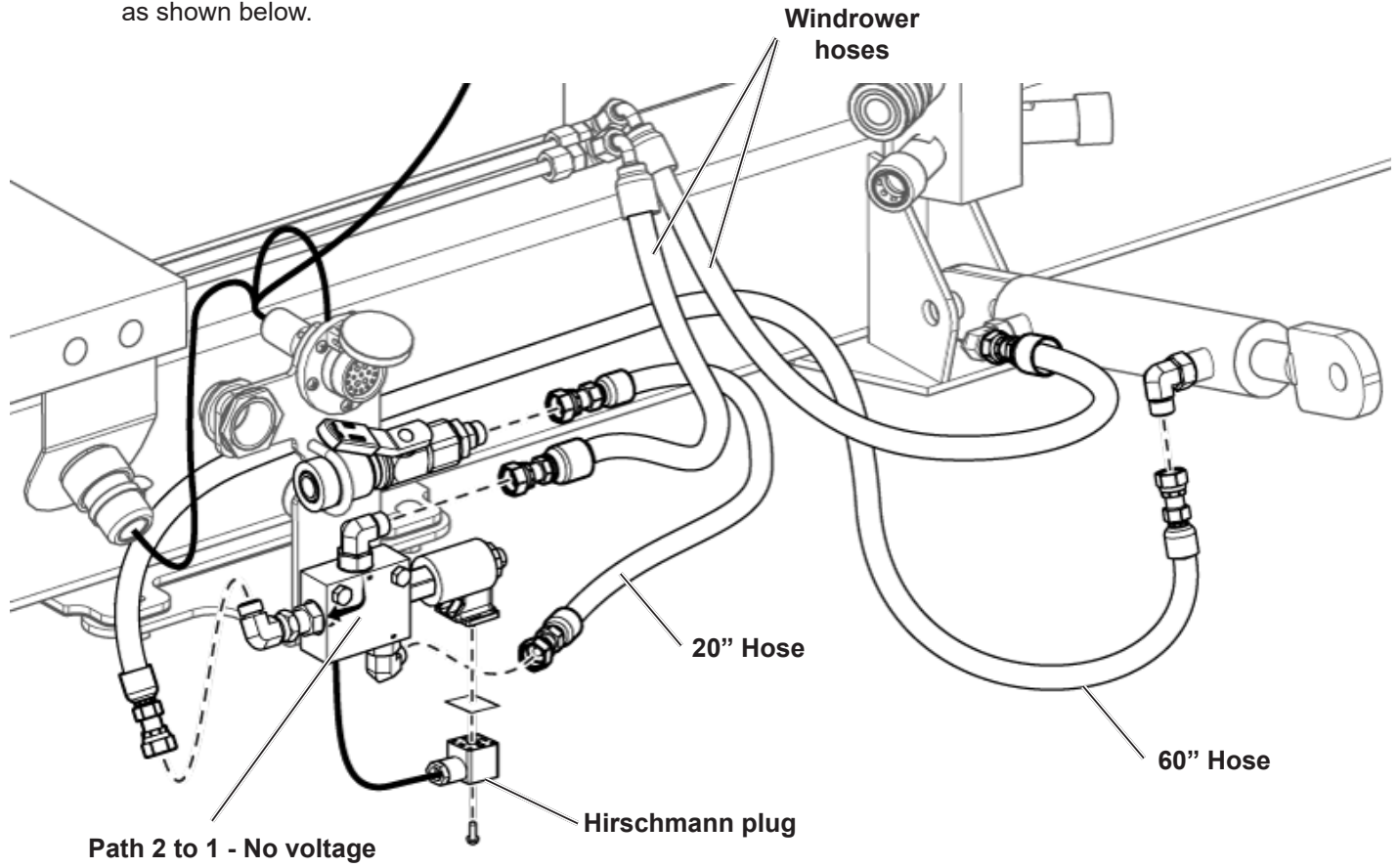

Fig. 45

5.6 - Basic Windrower Controls

Basic function controls are located on the multi-function handle, armrest controls, and Honey Bee Switch Box.

See the windrower operators manual for more details.

The reel lift/tilt select switch on the switchbox changes the function of the controls on the control handle. Select the reel symbol to control the reel height. Select the table tilt symbol to control table tilt.

See the Operation and Leveling sections for specific Reel Lift/Tilt and Float functions.

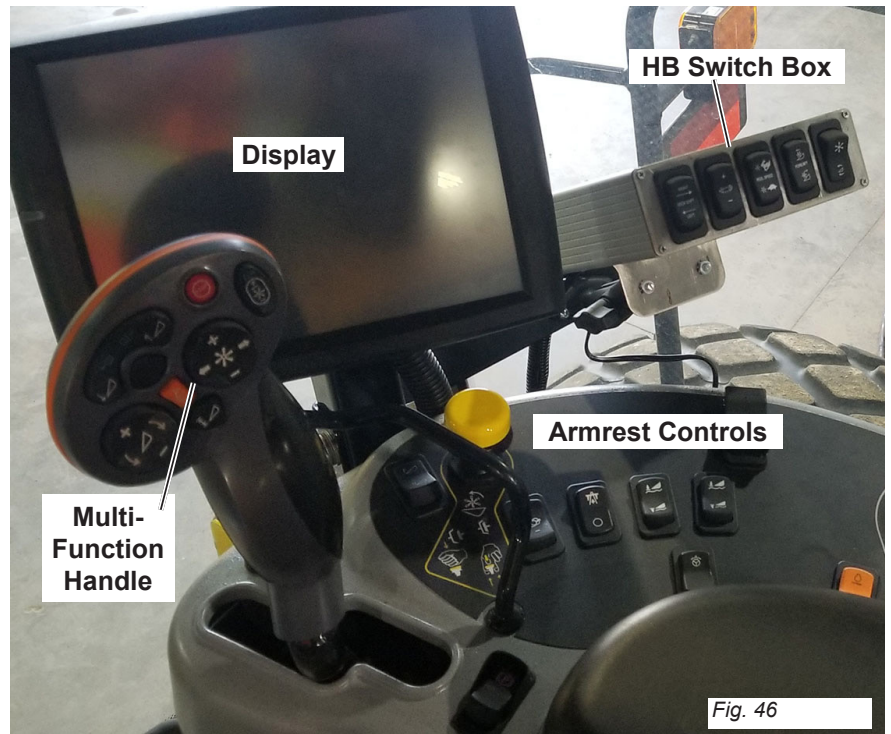

Fig. 46

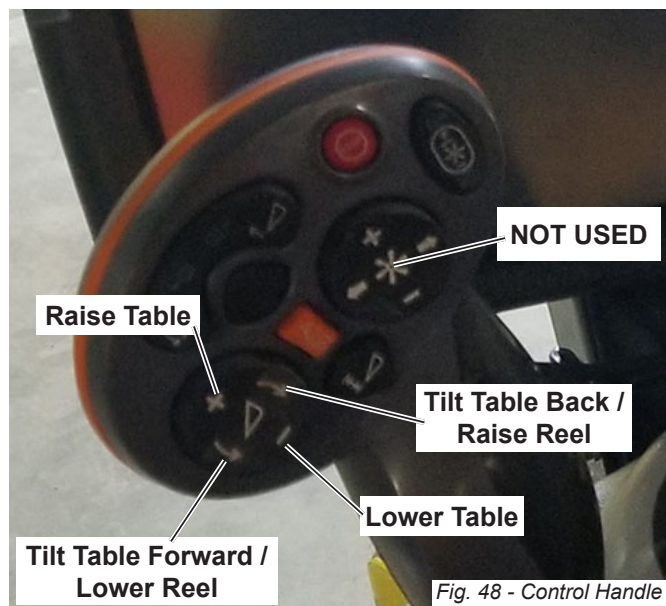

Fig. 48 - Control Handle

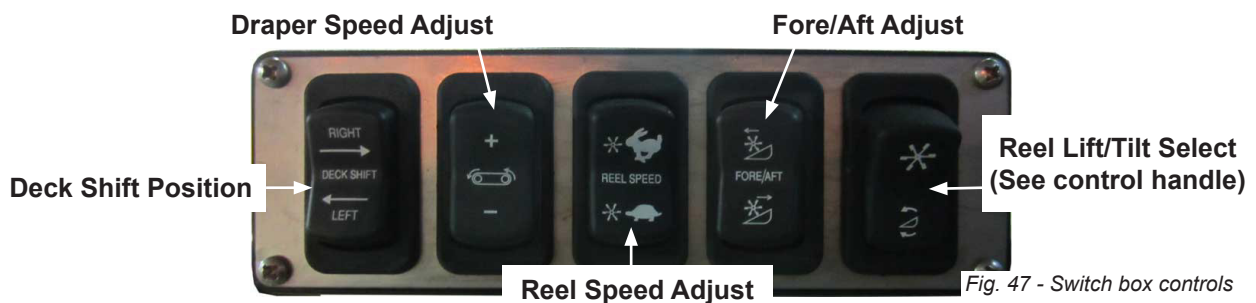
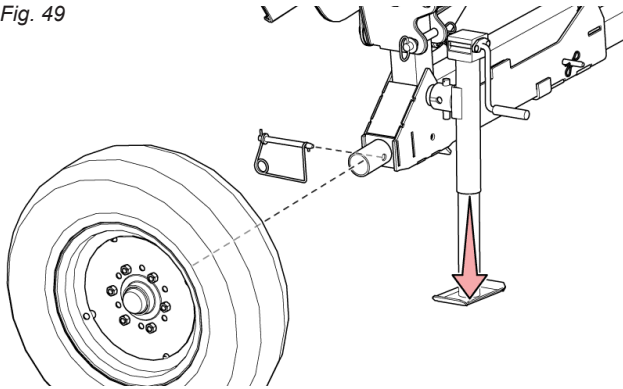

Fig. 47 - Switch box controls

5.7 - Mounting the Swather to the Windrower

1. Park the swather on firm, level ground, where it will be easily accessible for the windrower operator to pick up. Ensure the swather is level.
2. Lower the screw jack, located on the side of the transport axle, and raise the axle until the wheel assembly clears the ground.

Fig. 49



3. Remove the quick pin securing the hub and spindle, and remove the wheel assembly. Store the wheel assembly in an appropriate location, or if the gauge wheel option is present, install the wheel into one of the gauge wheel mounts and secure with the quick pin.

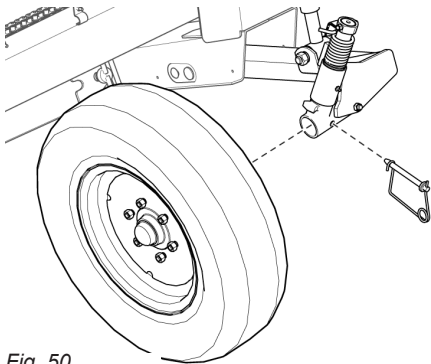

Fig. 50

4. Select 'Header Removal Mode On' as described in your windrower's operator manual.

5. Secure the mounting arms to each mounting roller.
 - Pivot the locking plate upwards to allow the lever to move freely.
 - Pull the lever away from the mounting arm to disengage.
 - Leave both mounting arms in a disengaged position.
 - (Refer to CNH Operators Manual for more detail)

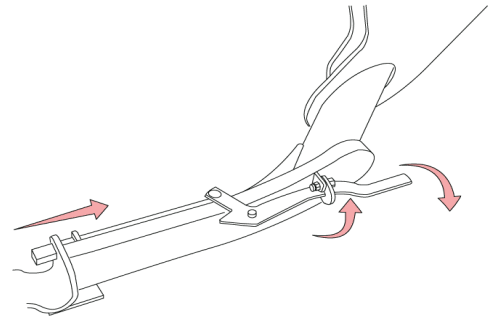

Fig. 51

6. Move the power unit into position, lining up the lift arms with the mounting boots. Ensure the arms are low enough to move under the boots.
7. Move forward and raise the lift arms until they are firmly set into the mounting rollers. Ensure the end of the arm has fully engaged the mounting rollers. Do not lift the table any higher at this point.

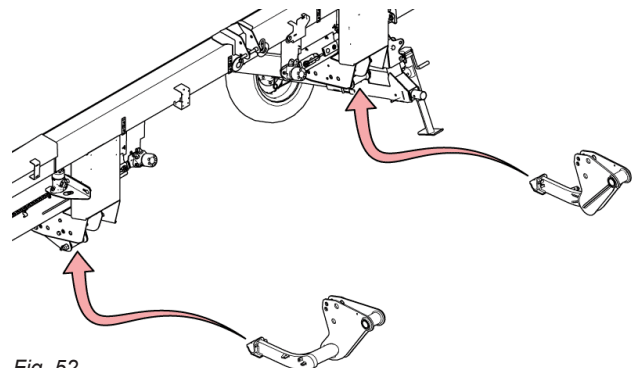

Fig. 52



Shut the engine down, wait for all moving parts to stop before leaving the cab. Ensure the park brake is set.

- Secure the tilt cylinder to the mounting bracket on the upper tube of the swather as shown below. **Note:** Table may need to be lifted higher to be connected. Use the tilt switch on the front of the power unit to extend/retract the cylinder to align holes

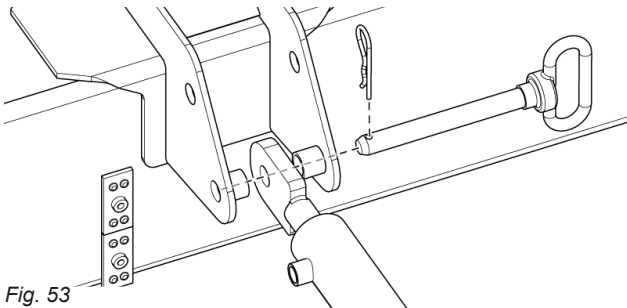

Fig. 53

- Secure the three quick couplers and the 21 pin plug to the windrower as shown below. The 21 pin plug is stored on the bracket on the rear of the swather's upper tube as shown in figure Fig. 55.

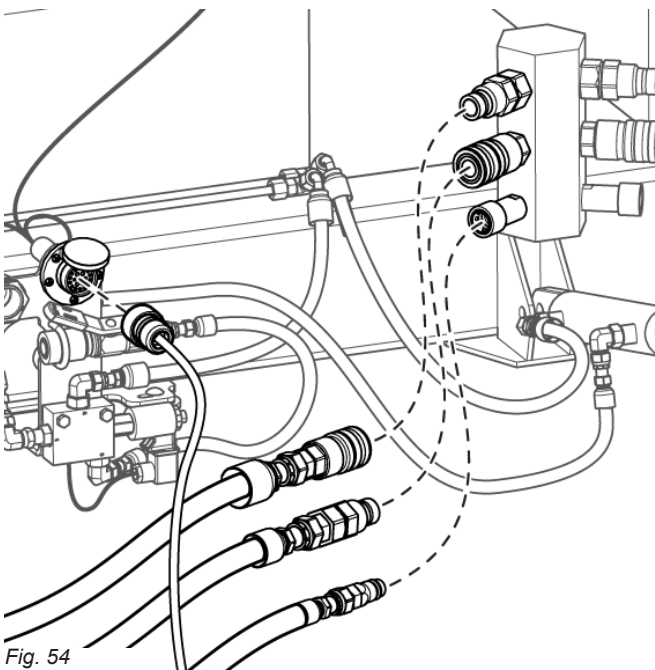

Fig. 54

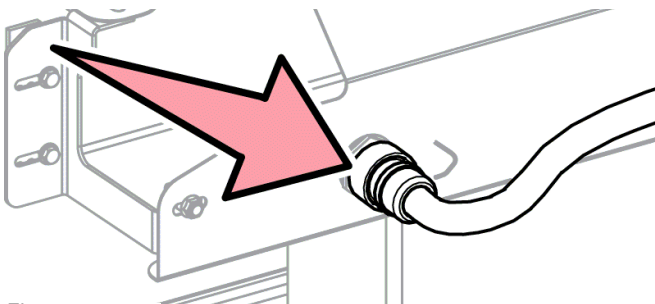

Fig. 55

- Locate the reel lift quick coupler on the storage bracket. Secure it to the quick coupler on the bracket that was installed on the front of the windrower as shown below.

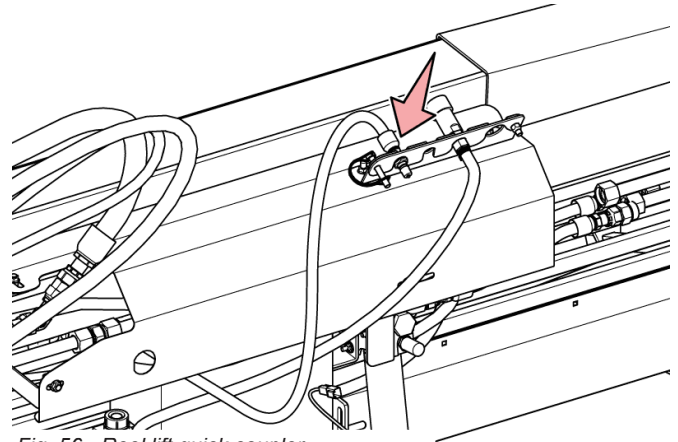

Fig. 56 - Reel lift quick coupler

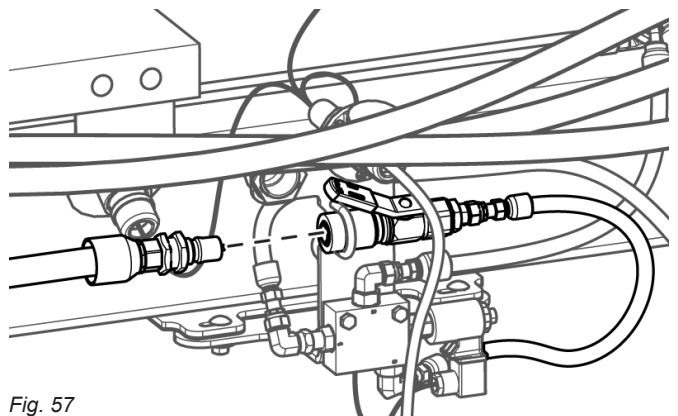

Fig. 57

- Engage the header quick attach located on the lower rear corner of each lifting arm (reverse order of Step 5 on page 34)
- Select 'Header Removal Mode Off' from the windrower settings as described in your windrower's operator manual.
- Set the header width in the windrower system to the appropriate width for the header being used, see windrower's operator manual for details.

5.8 - Store the Transport Axle

1. Lift the table in order to have ground clearance
2. Lock windrower height
3. Remove the wheel assembly from the cutter-bar side of the table, and store in an appropriate location, or install onto the remaining gauge wheel mount
4. Remove the axle jack and place it in a secure storage location.

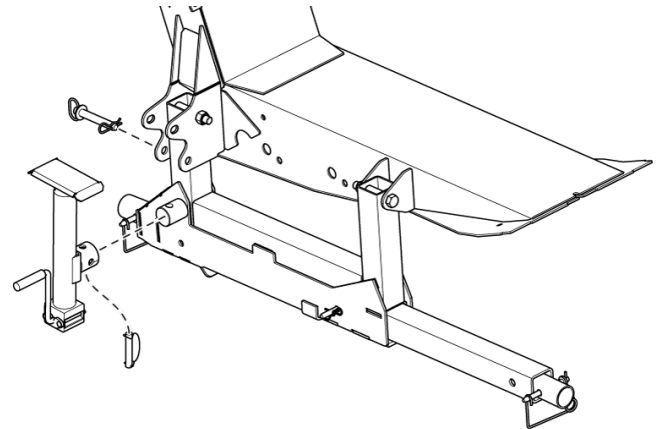

Fig. 58

5. Remove the pin which holds the axle extension in place, slide the axle extension inside the axle tube, then secure it in place with the pin.

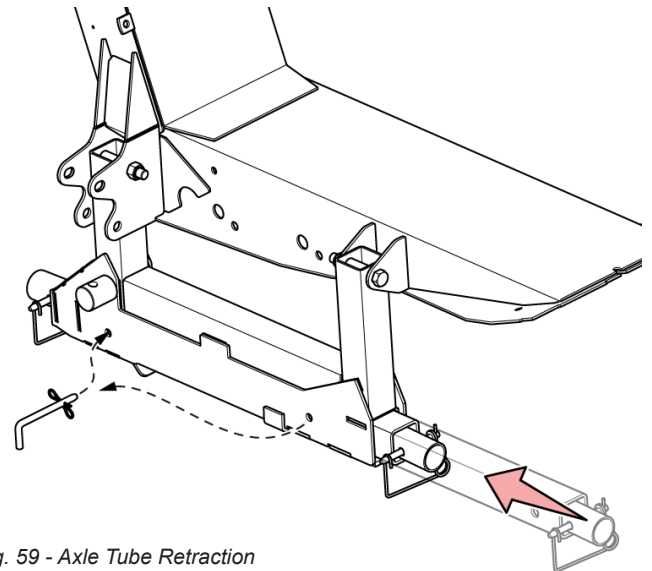

Fig. 59 - Axle Tube Retraction



WARNING

The axle is heavy!

6. Swing the axle up, and secure using the pin.

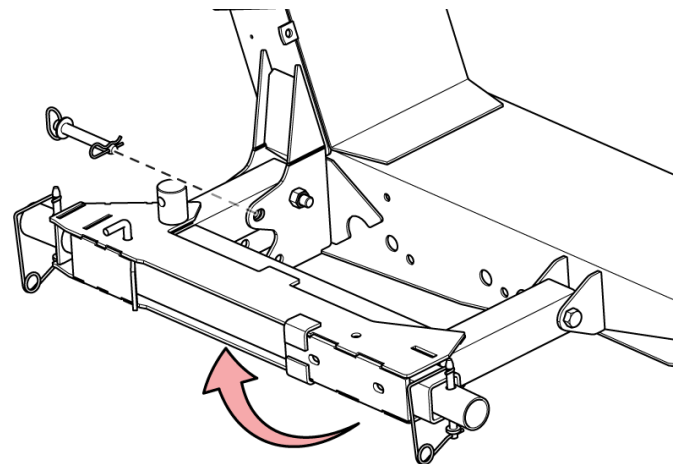

Fig. 60 - Axle in Field Position

5.9 - Store the Transport Hitch

1. The swather should still be lifted from the ground at this point, with the table safety lock in place.
2. Fully retract the jack on the left end of the table by turning the jack handle, retract the lower leg of the jack and secure it with the jack pin.
3. Release the hitch clamp, remove the chain and slide the jack off the hitch tube. Store the jack as shown in Fig. 63, and tighten the clamp.
4. Pull the Lock Pin on the hitch tube and slide the tube into the storage sleeve. Refer to Fig. 64. Attach the hitch safety chain to the storage stub as shown in Fig. 65.

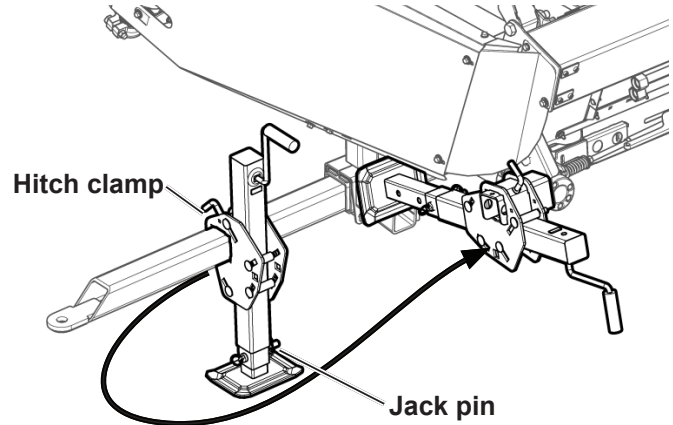

Fig. 62

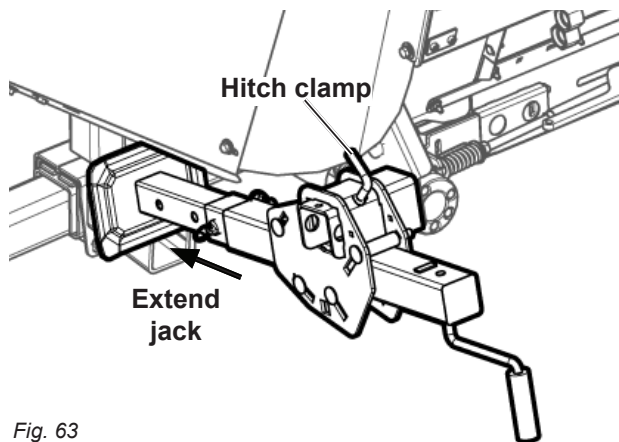

Fig. 63

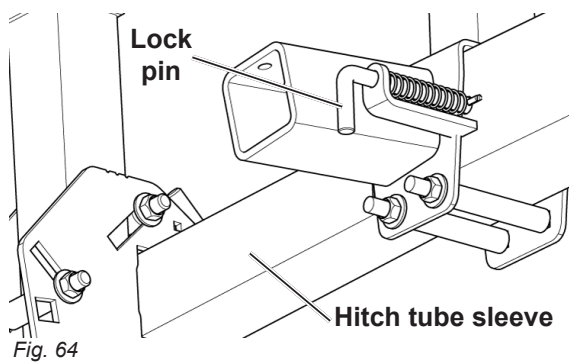

Fig. 64

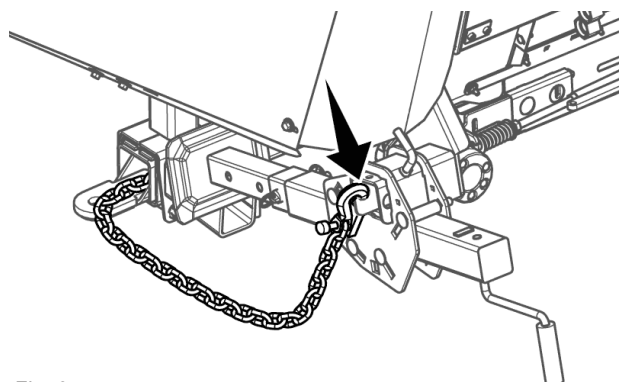

Fig. 65



If excessive vibration occurs, extend the jack until it contacts the hitch tube storage sleeve, as shown.

5.9.1 - Double Swath Option

For the double swath option, you'll need to completely remove the hitch tube from the LH side of the table.

Locate and remove the hitch pins at both ends of the hitch tube sleeve to remove it from the table. ("Fig. 61")

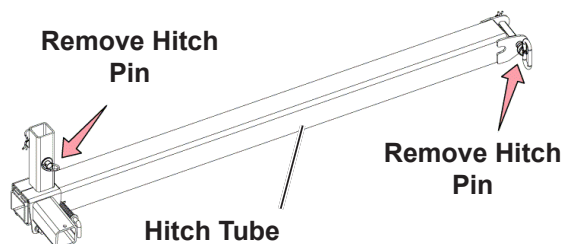

Fig. 61

5.10 - Calibrate Power Take-Off (PTO) Draper (6-cylinder units only)



To avoid injury, ensure power unit is on level and firm ground. While calibrating, you will be prompted to start the engine. Before starting, use the horn and clear the area of people and pets. Failure to do so could result in serious injury or death.

NOTE: Before calibration begins, make sure the hydraulic oil is at operating temperature. If the hydraulic oil is not at operating temperature, an “A-093” code will be given to indicate “Hydraulic oil temp low”. Until oil is at sufficient temperature, the maximum engine RPM will be limited.

These instructions will calibrate the header drive for a draper header on a 6-cylinder windrower. Be sure to set the header type to “Draper” on the “Header” screen. (Home>Toolbox>Header)

1. Turn the ignition key to “On”, but do not start the engine.
2. From the home screen, navigate to the “Calibrations” screen.
3. In the calibrations menu, choose “2023 Honeybee Draper PTO calibration” (if available), or alternatively “PTO-Draper”, then select OK to continue.
4. You will see a warning to make sure the Header RPM sensor is installed, configured and functioning correctly and that the MFH/MFP Lever is in neutral. The RPM sensor can be found on the left hand knife drive (see “Fig. 66”). Ensure the gap between the sensor and disc is between 1/32” and 1/16”. When this is set, press “Enter” to continue.
5. Start the engine as prompted.
6. Engage PTO as instructed to continue the calibration.
7. When you have finished calibrating, you should see a message that reads “Calibration Successful”. You will then be instructed to turn off the engine.

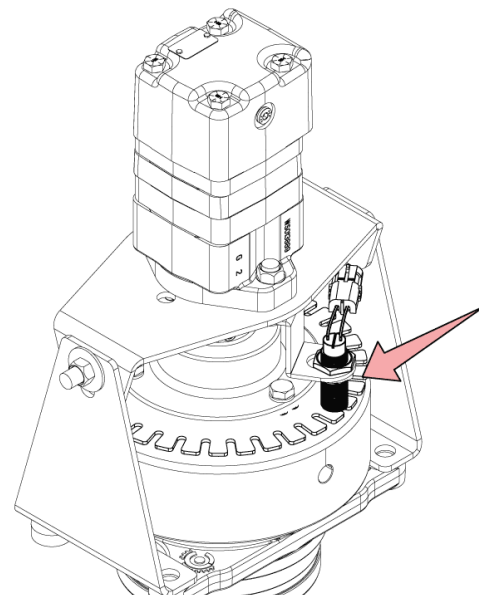
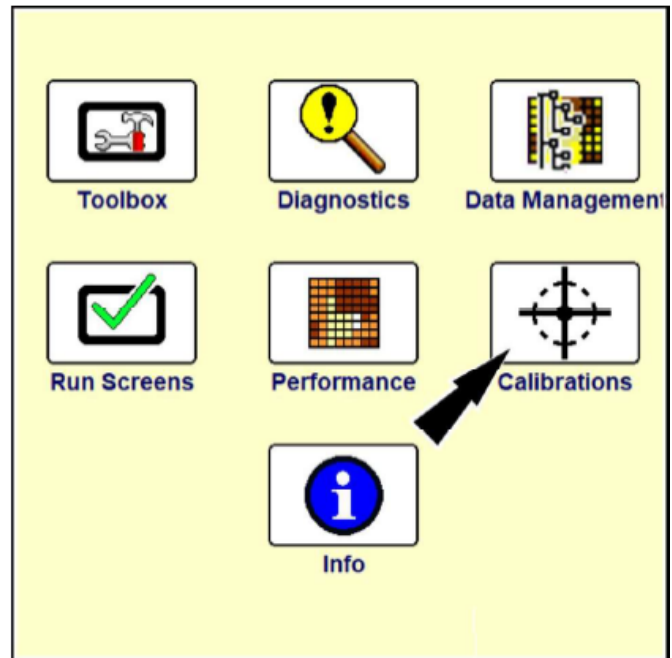

Fig. 66

5.11 - Mounting Checklist

	Strut mounting boots installed securely in table
	Lift arms seated in boots and locked in place by lift arm locks.
	Header tilt cylinder installed securely to center of table
	Transport axle and hitch tube in storage (field) position
	Transport parts stored for future use
	Gauge wheels installed and secured (if equipped)
	Main hydraulic hoses connected to table quick couplers
	Reel lift hose connected to tilt circuit
	All electrical connections complete
	Reel tie down straps/wires removed
	Crop dividers and divider pipes installed
	Swather table leveled

5.12 - System Tests

Once all installations have been completed, and checked, the entire system should be tested to ensure everything is operating correctly. If a fault is detected, troubleshoot, and correct as needed.



If possible, the following tests should be completed with an observer present at a safe location outside, with a clear line of sight to the operator. If this is not possible, complete the tests with the cab door open, so the operator can more easily detect unusual noises.

5.13 - Hydraulics, Electric, and Mechanical Checklist

	Check all fluid levels and top up if needed.
	Start the windrower, run the engine at low idle. Raise and lower the swather and adjust the windrower settings to achieve a suitable rate of movement as described in the windrower's operator manual . Advance engine RPM to normal operating range, test the rate again, and adjust as necessary.
	Return the engine to idle RPM. Engage each of the swather controls, one by one, to test the electrical and hydraulic connections. For each system you activate, monitor its readings on the display to ensure they are accurate.
	Engage all systems, and slowly advance throttle to normal operating RPM. Check that all systems are running at normal speed with no signs of problems or interference.
	Stop all systems, turn the engine off. Inspect the swather to ensure everything is secure, and there are no signs of abnormal operating conditions. Make adjustments as required, and re-test as necessary.
	Check hydraulic fluid levels and top up if necessary.

6 - Operation

6.1 - Initial Start-up



Keep bystanders, especially children, away from the machine during these operations. Before attempting these steps, complete the mounting checklist to assure the swather is securely mounted, and be familiar with all cab controls.

1. Unlock the lift arms by disengaging the platform lock as per windrower manual.
2. Start the windrower (see windrower operators manual) and lower the swather to the ground.



Shut the engine down and wait for all moving parts to stop before leaving the cab. Ensure the park brake is set.

3. With the swather completely lowered, (in full contact with the ground) inspect the swather for damaged or loose parts, nuts and bolts. Repair or replace any such parts as required.
4. Check hydraulic reservoir oil level on the windrower. Fill to recommended level according to instructions in windrower owner's manual.
5. Ensure that all protective shields are in place and properly secured.
6. Check that transport/gauge wheel tires are inflated to the recommended pressure of 80 psi. (550 kPa).
7. Check all hydraulic hoses and fittings to be sure they are tight, properly connected, and that no hose damage has occurred during mounting. Repair or replace any damaged parts before re-starting the machine.



Do not operate this machinery with defective hoses or fittings. Ensure hydraulic pressure is released before checking or attempting repairs. Pressurized hydraulics can cause serious injury.

8. Lubricate the swather. See service points in the Lubrication section of this manual.
9. Restart the windrower (see windrower Operators Manual). Engage the Park Brake.

6.2 - Reel Lift Controls

Depress the Right Hand switch on the Honey Bee Switch Box to engage Reel Lift mode. Depress the platform tilt button, on the multi-function handle to raise the Reel until the cylinders are fully extended. Hold the button on momentarily, then drop the reel to its lowest position (cylinder fully retracted). Complete this cycle at least twice to ensure the system is working properly.

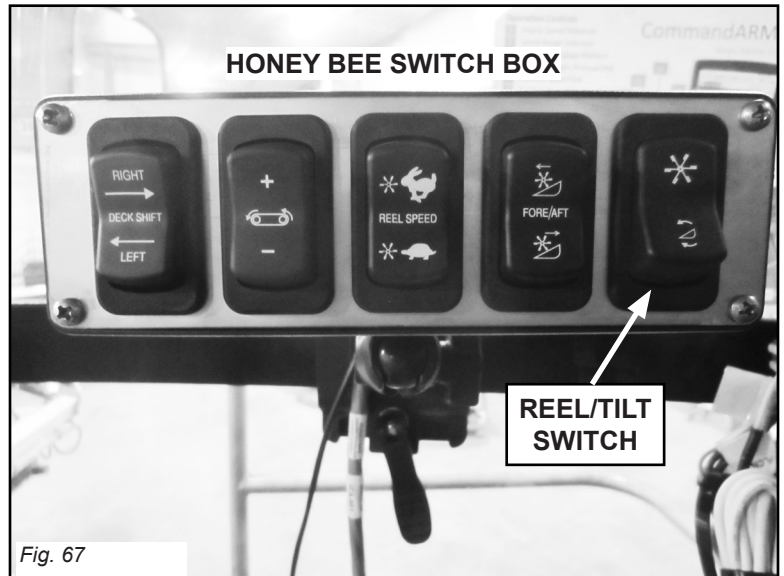

Fig. 67

NOTE!

The Reel Adjust Quad is not used for reel position adjustment. See the levelling section for details

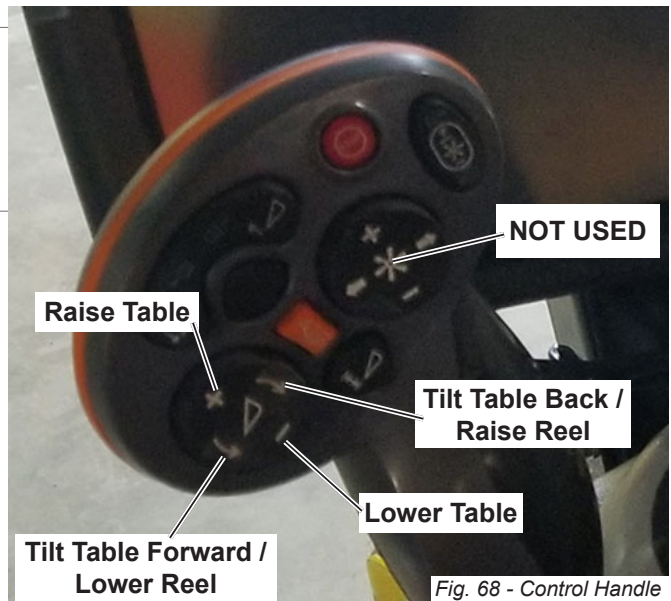

Fig. 68 - Control Handle

6.3 - Bleeding Air Out Of Reel Lift Circuit

If the reel does not go up or down evenly, it may be necessary to bleed the slave cylinder. Complete this procedure only when the swather drive is disengaged and the swather is resting on the ground. Lower the reel to the bottom of the cylinder stroke. The reel cylinders have a center to center collapsed length of 24". Fully extended cylinder length is 40".

Cycle the reel to the top of the stroke, then lower the reel until about 2" of cylinder rod remains exposed. Shut the windrower down. Wait for 10 to 15 minutes to allow the air bubbles in the oil to dissipate. Loosen the bleed port cap on the slave cylinder (far right hand cylinder). Air and oil will escape, and the reel will settle. Tighten the bleed screw (cap) and cycle the reel again. If needed, repeat this procedure.

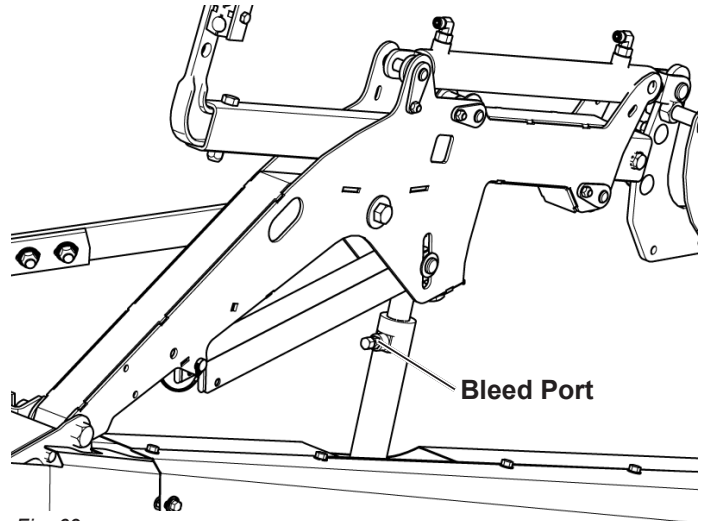

Fig. 69

NOTE!

Because of expansion in hydraulic lines, it is normal for the slave cylinder to lag slightly when lifting the reel

6.4 - Single Reel Lift Circuit

When the operator opens the valve in the windrower, oil is forced into the barrel end of the left hand master cylinder, as the cylinder piston rises, oil on the top side of the piston is forced out of the rod end port, into the port on the barrel end of the slave cylinder.

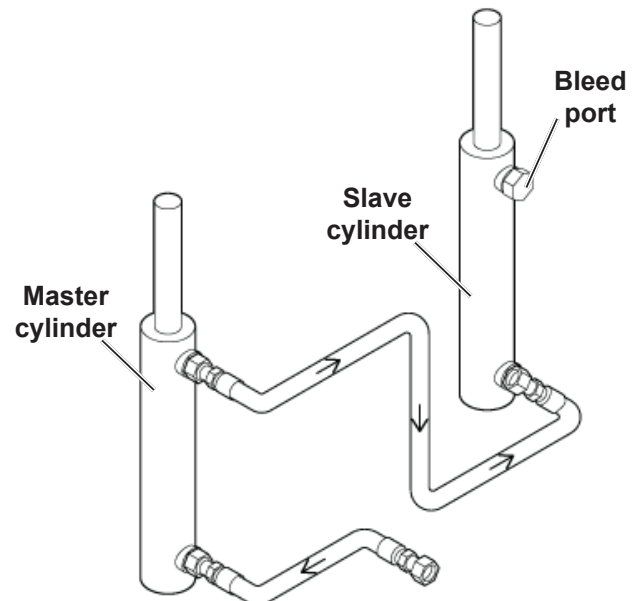

Fig. 70

6.5 - Additional Checks:

1. Unlock the platform.



If the windrower will not lift the swather table, see the Troubleshooting section of this manual.



Be certain no one is standing near the machine while you are raising or lowering the swather.

2. Raise and lower the swather table to ensure the lift cylinders are working properly.
3. With swather lowered to the ground, and the windrower shut down, check the tension on each draper. If adjustments are required, see the Draper section of this manual.
4. Re-start the windrower, engage the parking brake. Engage platform drive switch (see windrower Operator's Manual) with windrower at low idle.



If any leaks appear, shut the unit down, and switch off the engine immediately. Locate the source of the leak, and repair before re-starting.

5. Increase engine speed, until the windrower is at normal operating engine rpm, check and set the following:
 - Reel speed.
 - Draper speed.
 - Draper tracking.
6. If changes are required see the appropriate section of this, or the windrower manual.
7. With the swather lowered to approximately 2 inches (5 cm) from the ground, stop the windrower, shut the engine down, and check the following:
 - Swather leveling (end to end).
 - Swather cutting angle.
 - Gauge wheel height.
 - Reel mount bolts.
 - Knife head section bolts, Knife head bearing bolt, and bearing block bolt.
 - Knife drive support/crank bolts.
 - Connector bar bolts on knife back.
 - Knife drive mounting bolts.

6.6 - Problems frequently encountered during start-up and break in period

High Hydraulic Pressures - Cold Oil

- Sticky Draper
- Sticky or Tight Knife
- Draper Too Tight

Reel Will Not Raise

- Low Oil Volume from windrower
- Line Restriction
- Valve not open

6.7 - Full Dismount



Park the windrower on a hard, level surface. Engage the park brake.

1. With the windrower running, lower the reel to its lowest position and retract fore/aft fully. Lower the swather to the ground.



Shut the engine down and wait for all moving parts to stop before leaving the cab. Ensure the park brake is set.

2. Uncouple all wires running from the windrower to the swather (21 pin connector).
3. Uncouple all hydraulic hoses connecting swather to the windrower. Secure the main hydraulic hoses so that they will not interfere with the windrower or the swather when the windrower is being backed away from the swather.
4. Start the engine, lift the table to its fully raised position.



To raise table to full height, windrower float pressure will need to be increased.

5. Lock platform in fully raised position as described previously, and in your windrower Operator's Manual.



Shut the engine down and wait for all moving parts to stop before leaving the cab. Ensure the park brake is set.

6.8 - Self Storing Hitch – Transport Position

6. To convert the hitch from storage to transport mode, remove the safety chain from the storage stub. Release the pressure on the jack, loosen the hitch clamp, and slide the jack off of the stub. (“Fig. 71”)
7. Pull the lock pin on hitch tube sleeve, and then pull the hitch tube out of the hitch tube sleeve. Reinsert the lock pin to secure the tube. (“Fig. 72”)
8. Install the jack onto the hitch tube, and tighten the hitch clamp to secure it in place. (“Fig. 73”)
9. Extend the lower leg of the jack to a suitable length and secure with the jack pin.
10. The swather should still be lifted from the ground at this point with the table safety lock in place.

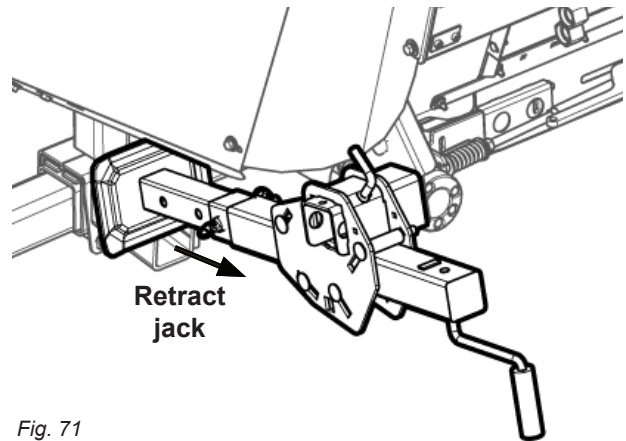

Fig. 71

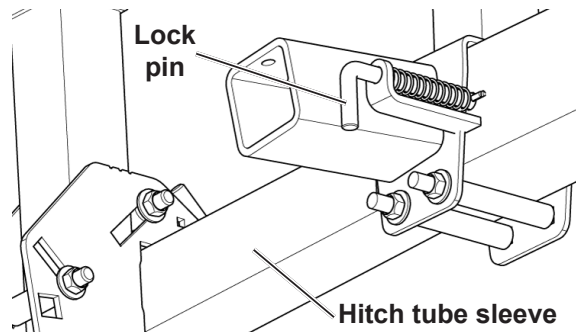

Fig. 72

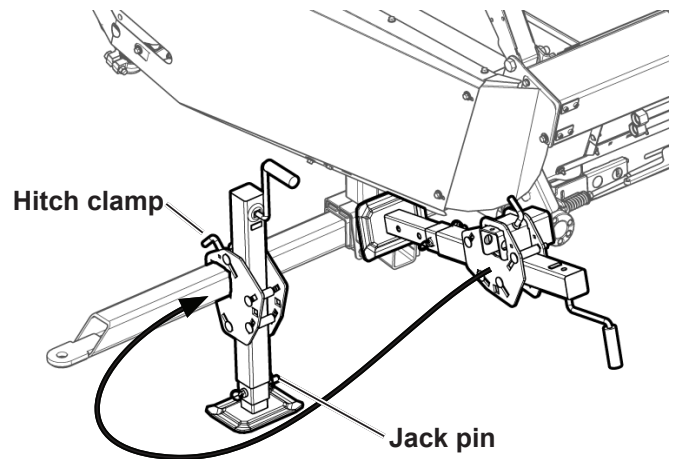

Fig. 73

6.9 - Install Transport Axle

11. Carefully lower the axle from the field position to the transport position. Ensure the hitch pin has been inserted back into the bracket in the transport position.



The axle is heavy!

12. Remove the hitch pin securing the extension inside the axle. Pull out the extension and relocate the pin to secure for transport.
13. Install the wheel assembly onto the extension on the cutter bar side of the table, insert lock pin into spindle mount and secure with safety clip.
14. Install the transport axle jack to support the weight at the rear of the table.

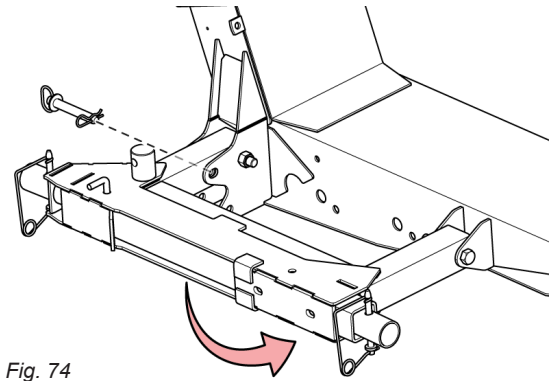

Fig. 74

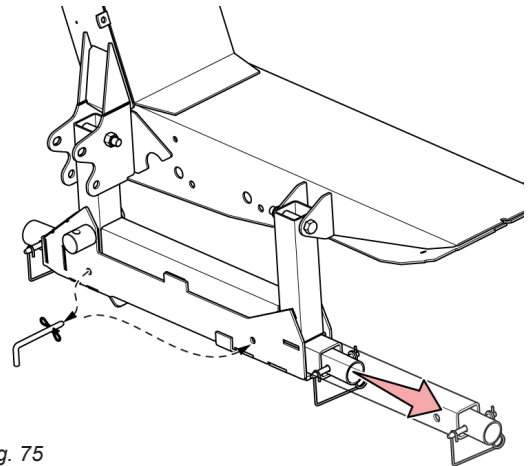

Fig. 75

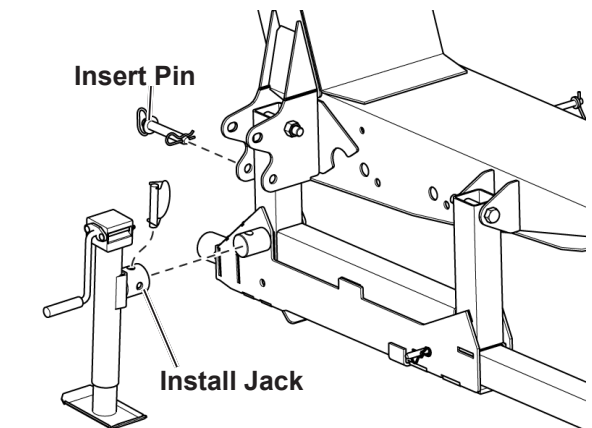

Fig. 76

**NOTE!**

As long as the table is still fully raised, there won't be any pressure on the pin.

15. Place the platform lock in the unlock position.
16. Restart the windrower.



Shut the engine down and wait for all moving parts to stop before leaving the cab. Ensure the park brake is set.

17. Keep the float pressure high and carefully lower the swather until the weight is fully on the transport wheel, transport jack and hitch jack.
18. While float pressure is still high, lower the header as close to the ground as possible while maintaining header weight on the lift arms.
19. Disengage the lift arm safety locks and remove safety pins if they exist.
 - Pivot the locking plate upwards to allow the lever to move freely.
 - Pull the lever away from the mounting arm to disengage.
 - Leave both mounting arms in a disengaged position.
 - (Refer to CNH Operators Manual for more detail)
20. Lower the header to the ground.
21. Select 'Header Removal Mode On'
22. Disconnect the top-link - header may need to be lifted slightly to relieve pressure on top-link.
23. Lower the lift arms until they disengage from the header
24. Ensure all hoses and harnesses are disconnected, then slowly back the windrower away from the header.

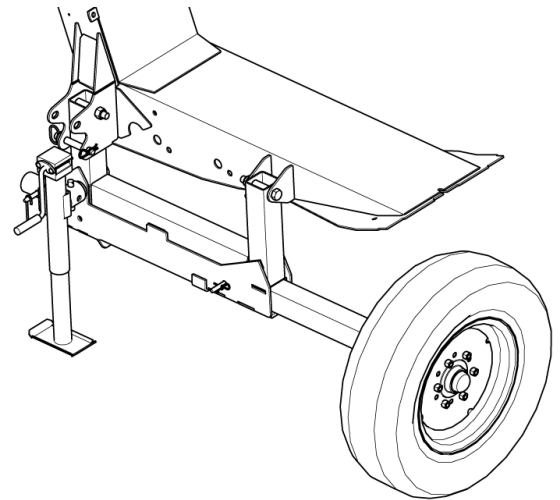

Fig. 77

6.10 - Final Dismounting Steps.



If the swather moves, stop immediately and find the cause.



Once clear of the swather, engage the park brake. Shut the engine down and wait for all moving parts to stop before leaving the cab.

25. Attach the rear wheel and secure with the hitch pin.
26. Retract the jack, remove it and re-install it in the storage position.
27. Check that the swather is level. If necessary adjust the height of the hitch jack.
28. Re-install the pins for the mounting boots.

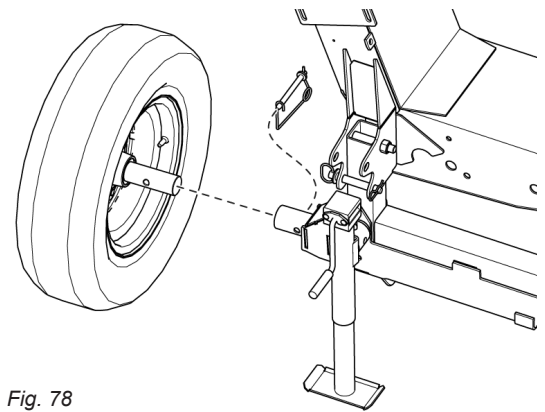

Fig. 78

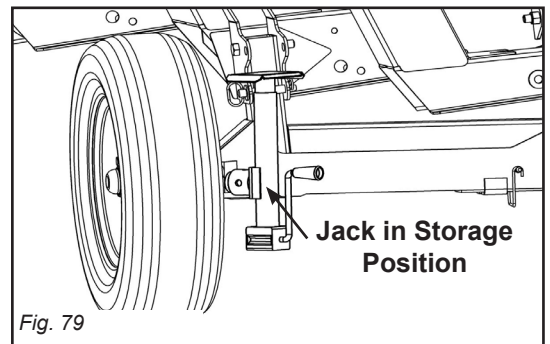

Fig. 79

6.11 - Hydraulic Hose Storage

29. Secure disconnected hydraulic hoses in the storage bracket as shown below. Connect the case drain hose to the storage overflow tank, this will catch any overflow in the event of thermal expansion.



Ensure the all disconnect hoses have their dust plugs installed.

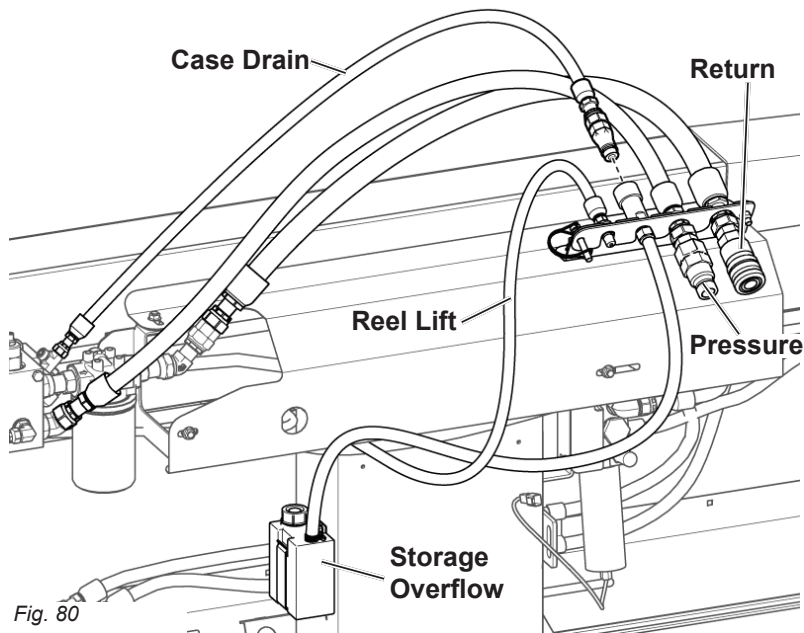

7 - Reel

7.1 - Reel Drive

Depending on your table model, the reel is driven by either one or two hydraulic motors with a direct drive coupler to the reel.

Check coupler bolts and motor mount bolts regularly for tightness. Check alignment of motor to reel tube, and shim the mounting bolts if needed.



Reel motors are capable of bi-directional operation. As installed on the swather they run in one direction only and are supplied with unidirectional hydraulic oil flow. For this reason, it is important to mark the lines and their corresponding motor ports whenever you are removing hydraulic lines.

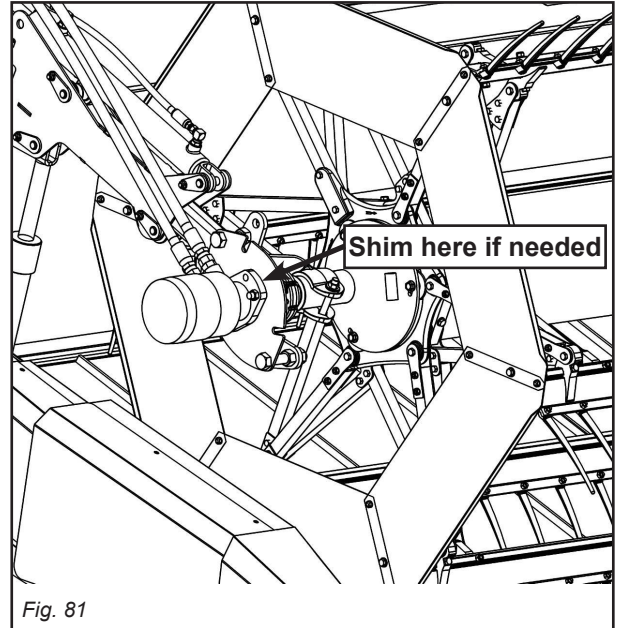

7.2 - Reel Speed Adjustment

Reel speed is controlled via the switchbox in the windrower cab. The maximum reel speed limit is controlled by the priority flow control cartridge as shown in section 8.14 on page 70, the flow control should only be adjusted if instructed to do so by the manufacturer or a dealer.

“Down” crops will require a somewhat higher speed than standing crops. Reel speed is determined by a control in the windrower. Adjust the reel speed so that the reel has the appearance of “pulling” the windrower through the field.

- If reel speed is set too slow, the crop will not be pushed against the cutter bar and swept onto the draper. This can result in a portion of the cut crop being pushed forward onto the ground. Slow reel speed may also cause a wrapping of the reel with cut crop, as it bunches along the front of the cutter bar. It is very important that the reel gently guides the crop onto the cutter bar, then sweeps it onto the draper.
- If reel speed is too high, the crop may be stripped or shelled out by the impact of the reel. The crop may also be pushed down before it can be cut, leaving uncut grain in the field. Excessive reel speed may also cause cut crop to wrap onto the reel, as the crop does not get a chance to fall onto the draper.
- In general, hay crops can be cut using higher reel speeds.

7.3 - Reel Position

7.3.1 - Hydraulic Fore & Aft

All swather reels are equipped with hydraulic fore and aft, controlled from the windrower. This feature allows the operator to move the reel assembly forward and backward.

Note: The table will be shipped with reel tie wires holding the fore/aft in place. Be sure to remove these before operating.

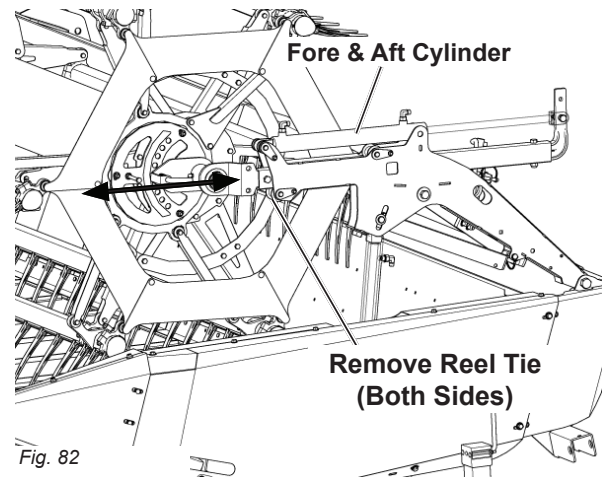

Fig. 82

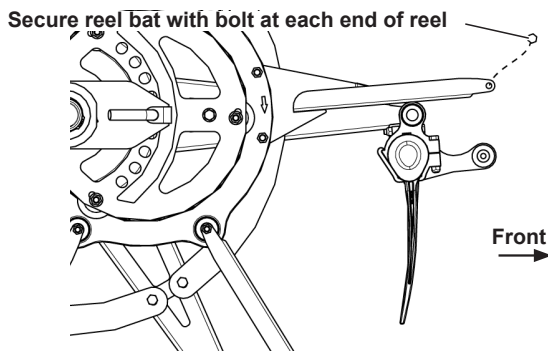

Fig. 83 - Raise reel fingers to operation position

7.3.2 - Reel Bat Timing Position

Raise the front reel bats into operational position & secure each end to timing arms using a 5/16" x 1-1/2" UNC bolt and 5/16" UNC C-Lock nut. (Fig. 83)

7.3.3 - Solid Reel Hydraulic Circuit

Pressure from the windrower feeds the barrel end of the left-hand reel lift cylinder. As the cylinder rod rises, oil is displaced. The volume of the rod on the left cylinder matches the volume of the barrel on the right cylinder. The displaced oil causes the right cylinder to raise. This cylinder has a vent to bleed air from the system.

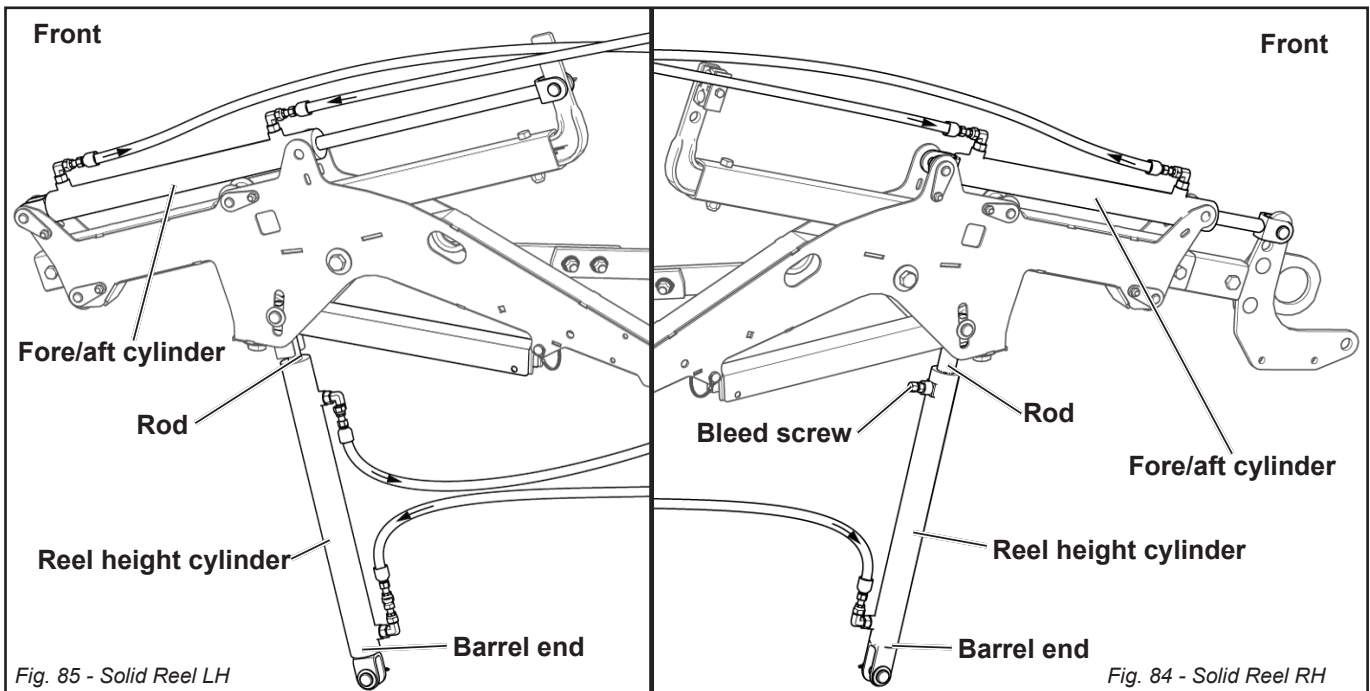

Fig. 85 - Solid Reel LH

Fig. 84 - Solid Reel RH

7.4 - Reel Arm Leveling and Height Adjustment

7.4.1 - Reel Height Adjustment

Proper setting of minimum reel height will protect against unexpected reel movements that can place reel fingers in contact with cutter bar.



Start the windrower, fully lower the swather and fully lower the reel.
Engage the parking brake, shut the windrower down, and allow all moving parts to come to a complete stop before exiting the cab.

1. Measure the distance between the reel fingers and the knife on the left and right and center of the reel. The minimum distance should be between 1" and 5" (2.5cm - 12.7cm).
2. If necessary, the reel height can be adjusted via the adjustment bolt on each reel arm. Turn the bolt clockwise to raise the reel, turn the bolt counter-clockwise to lower the reel.

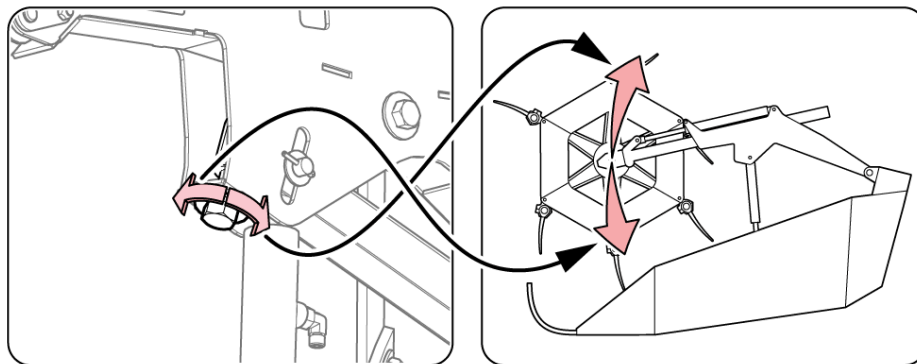

Fig. 86 - Reel Height Adjustment



NOTE!

If slightly different heights for each end are desired, perform fine adjustment only, keeping the lock pin hole locations the same on both ends.



When servicing the reel, it is necessary to have the reel locked into the service position with the reel arm lock, or lowered to its lowest position, this will prevent sudden drops in the event of hydraulic failure.

7.5 - Reel Centering

Measure the clearance from the end shield on the reel to the crop divider on each end of the swather. See the illustration below.

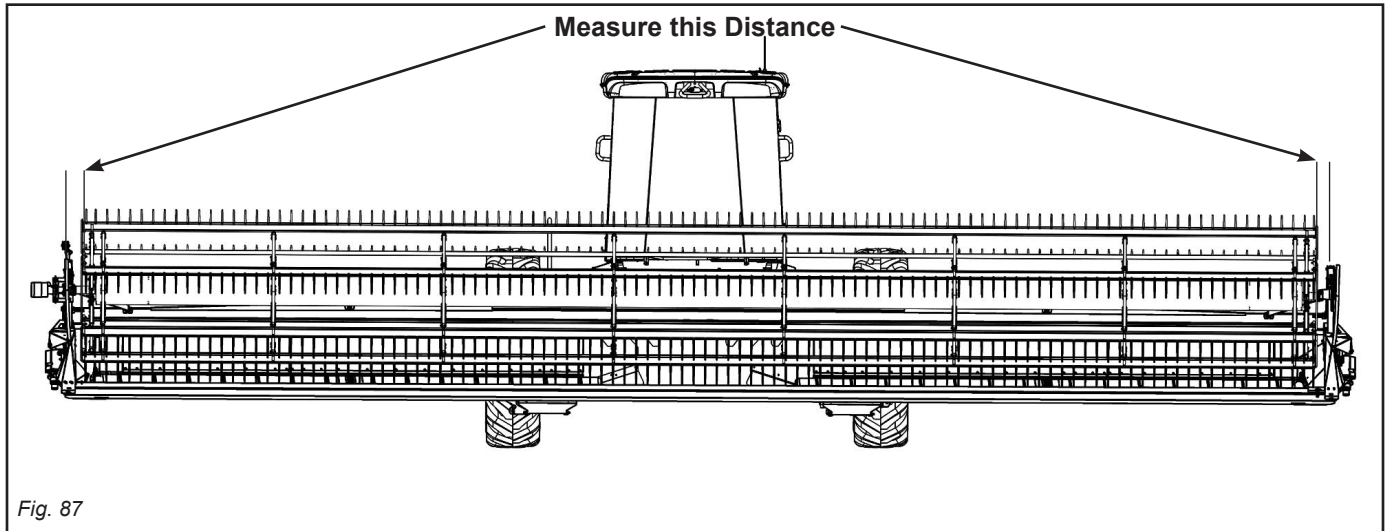

Fig. 87

If the reel is not centered on the swather, proceed as follows:



Start the windrower, fully lower the swather and fully lower the reel. Engage the parking brake, shut the windrower down, and allow all moving parts to come to a complete stop before exiting the cab.

1. Loosen the carriage bolts that secure the reel arm braces on both ends of the reel.
2. Push the reel arms until reel is centered.
3. Tighten bolts when centered.

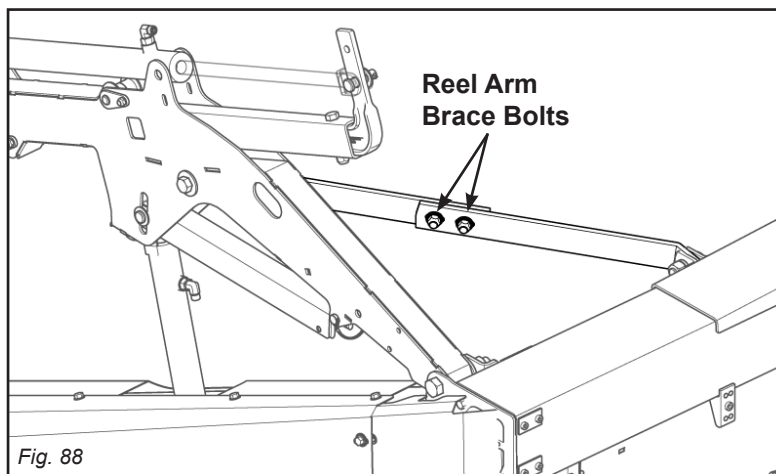
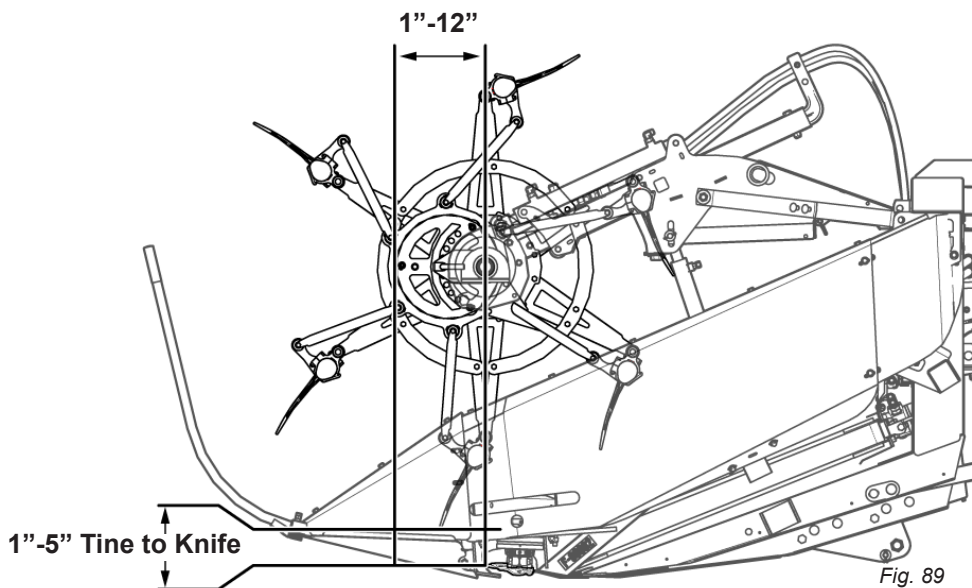

Fig. 88

7.6 - Placement of the Reel on the Swather

The distance from the tip of the guard to the center of the Reel Tube can be adjusted from 0" to 12" (300 mm) depending on the crop.

- Normally the more "down" the crop, the further ahead the reel should be set. See next section.
- Setting the reel too far ahead will not push the crop into the knife, nor will it efficiently deliver it onto the draper.
- Set the reel tines the same distance from the guards on both ends.
- Adjust the reel height stops so that the tine tips miss the guards and sickle by at least 1" with the cutter bar fully raised, to avoid cutting tines, and breaking knife sections. Wider tables will require more clearance due to increased flexing.
- Normally the more "down" the crop; the closer the tines will need to be placed to the cutter bar, down to this 1" minimum.



7.7 - Reel Position in Down Crops

- The reel height in down crops should be low enough that the tines can lift the crop up and onto the cutter bar.
- The tines should be adjusted so they pick up the crop and lift it onto the cutter bar with a minimum of the crop carrying around the reel.
- The fore and aft position of the reel should be adjusted so the reel center tube is about 12 inches (300 mm) in front of the cutter bar so the crop is lifted before it gets to the cutter bar.



Care must be taken to ensure that the reel tines do not come in contact with the cutter bar. Tine contact will cause damage to the tines, knife sections, and guards. At no time should the reel tines contact the ground. Contact with the ground or with rocks will cause damage to the reel.

7.8 - Reel Position in Standing Crops

The reel height on standing crops is usually correctly adjusted when the reel bats contact the crop about midway between the cutoff point and the top.

The reel should be adjusted fore and aft so the reel center tube is slightly ahead of the cutter bar. If the reel is too far forward, the crop will not be pushed against the cutter bar and a portion of the cut crop will fall to the ground. If the reel is too far back, the crop is pushed down too low when it is cut and some of the heads will be missed.

7.9 - Reel Tine Pitch Adjustment

Plastic reel tines are attached to the leading side of the reel bats. To adjust the pitch of the tines, proceed as follows:

To avoid serious injury, raise reel, engage reel lift safety stops, shut OFF engine, set parking brake, and remove key before exiting the cab.

1. Firmly grasp the handle then pull and rotate lock pin to one side so it is disengaged from reel.
2. Lift the handle up for less aggressive finger pitch.
3. Lower the handle for more aggressive finger pitch.
4. Once desired setup is obtained, re-engage the lock pin.
5. Repeat this process for the other end of the reel to ensure each side has identical finger pitch.
6. Readjust reel height and reel fore/aft in order to maintain a minimum safe knife clearance (1" (2.5 cm))

Adjust tine pitch initially so tines are perpendicular to the cutter bar. Too great a pitch may cause the cut crop to be scooped up and carried around the reel.

For crops that are down or lodged, adjust reel so that center of reel is ahead of cutter bar, and adjust tines to be more aggressive, lifting the crop, yet dropping it onto the draper decks after cutting.

Tine pitch is critical to the operation of the swather. Adjust the tines to suit your individual needs and make note of the best settings for each of the crop conditions you encounter.

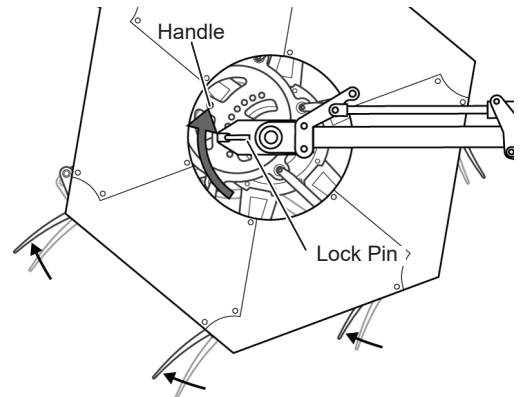

Fig. 90 Less Aggressive Finger Pitch (HB Reel)

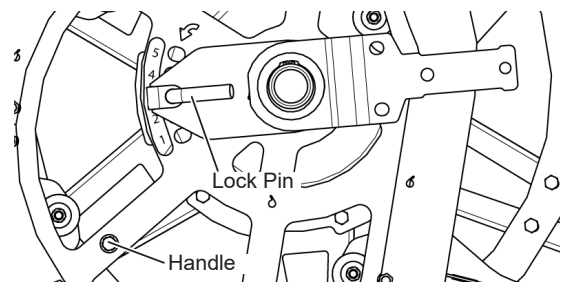

Fig. 91 Cam Reel Adjustment



Tine pitch must be the same at both ends of the reel.



If crop is building up in the center of a split reel, the fingers/tines may be heated and bent slightly to ensure the crop does not build up at the gap.

7.10 - Lubrication – Reel Shaft Bearings

Lubricate every 10 hours of operation (or daily) with multi-purpose lithium base type grease. Lubricate the grease zerk at each end of the reel shaft, and also at the center on double reel models.

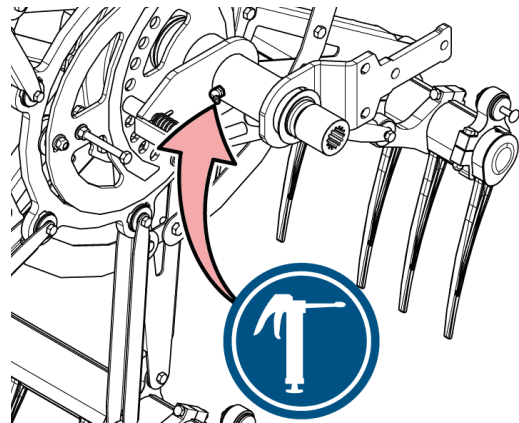

Fig. 92 Reel grease zerk

7.11 - Check Points Before Operation:



Always engage reel lift cylinder locks and table lift cylinder locks before working under or around raised reel. Do not rely on the power unit hydraulic system for support. A rupture or a leak in any part of the system will cause the table and reel to drop if the proper stops are not in place.

- All bolts are tight.
- Reel turns, by hand, without binding. (With some resistance from hydraulics.)
- Reel tines uniformly clear the knife.
- Reel arms are aligned. (No bow in the bat shaft or bat assemblies.)
- Auxiliary fingers have adequate clearance with side shields.
- Tine pitch has been set for the current application, and is uniform across swather.
- Hydraulic cylinders are functioning smoothly.
- Minimum reel height has been set correctly on the reel height control arms.
- Fore & aft hydraulic cylinders extend and retract fully.
- Vertical distance from the knife to the reel center is set for the current application.
- Reel is horizontally centered in the swather opening.

8 - Draper and Decks

There are two lateral drapers on the table which move the crop to the opening. All drapers must be set, and maintained properly to perform well. Quick release adjusters with spring tensioning allow easy access for cleaning, and maintain proper draper tension. Unpack the draper. Check the size to ensure it is correct for the size of the deck.



Lower the swather to the ground or onto stable blocks, whichever provides the most comfortable working height. Raise the reel to its maximum height and place the locks on the reel lift cylinders to prevent the reel from falling.

8.1 - Lining Up the Drive Roller

Prior to installing the draper, ensure that the drive roller (the draper roller with the motor) is properly aligned. This is done by setting the end of the offset plate flush with the c-channel of the deck. Adjust the eye bolt until the end of the idler plate contacts the stop on the offset plate if not so already.

Once extended, you should make sure that everything is parallel. The easiest way to do this, is to measure the distance between the roller and the closest cross brace on the draper deck. Make sure measurement "A" is the same distance as measurement "B". If it still does not line up, you may adjust the eye bolt again.

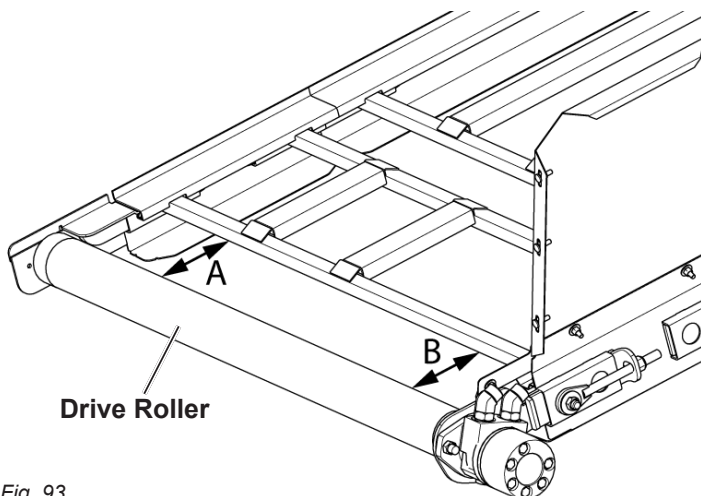

Fig. 93

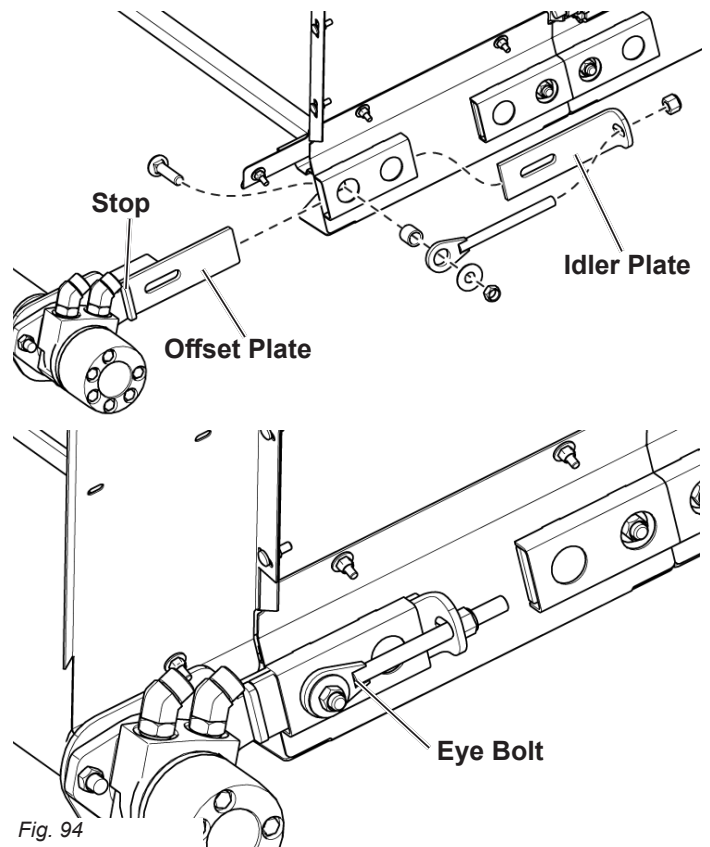
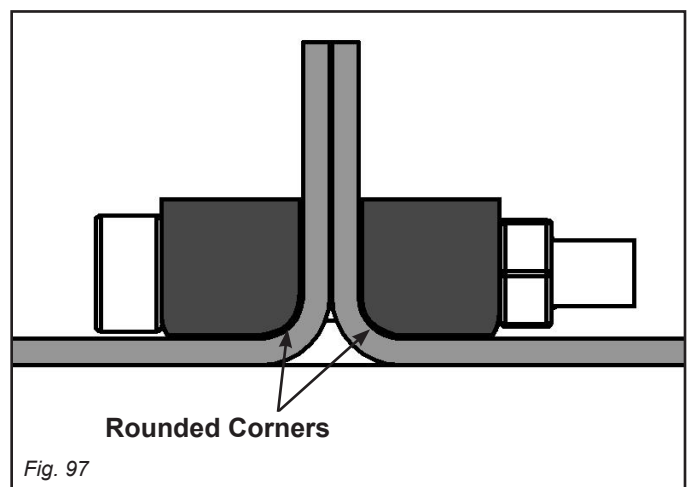
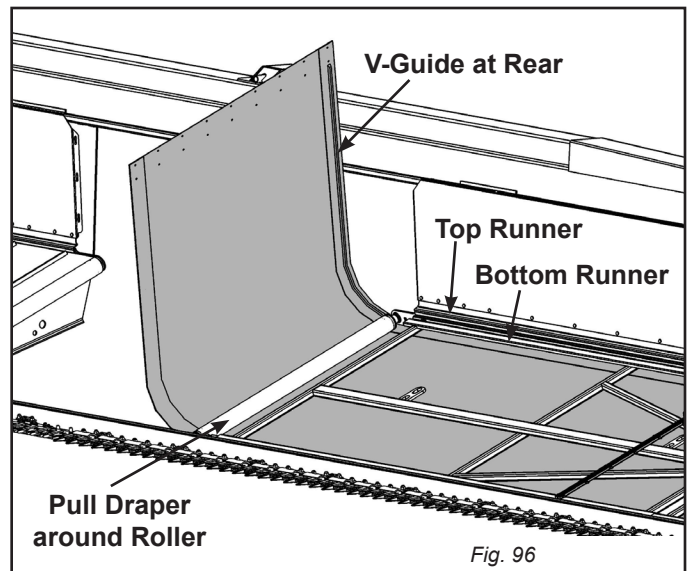
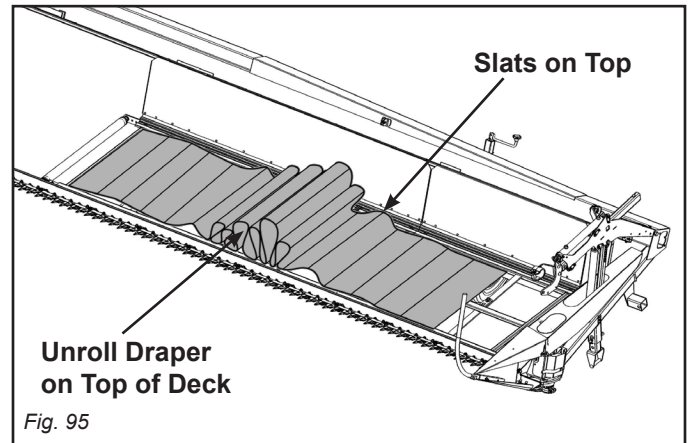

Fig. 94

8.2 - Draper Installation

1. Make sure that the quick release lever is in the open position prior to installing the draper on the deck. The location of the lever is shown in Fig. 99 on page 61.
2. Place draper bundle on the top of deck runners, and unroll with the slats facing up. Be sure to align the v-guide with the notched side of the roller toward the rear end of the swather.
3. Wrap draper around one of the rollers and feed draper into the bottom runner of the deck. The bottom runners will support the draper, and prevent it from hanging down.
4. Pull draper through bottom runner, and wrap around the other roller. Pull the ends of the draper together. Install a connector bar to close the joint. Take note of the position of the rounded corners on the connector bar.
5. The heads of the screws for the connector bar should be installed from the centre opening side. This helps prevent the crop being caught on the screws. Complete the installation by adjusting tension and tracking as described on the following pages.
6. Once the draper is installed on the draper deck, close the quick release lever (shown on following page) to apply tension to the draper.



8.3 - Tensioning

Proper tension must be maintained on the draper to prevent slipping on the drive rollers. The draper tension is changed by adjusting the idler roller of each deck.

8.3.1 - Spring Tension Indicator

The spring tensioners are equipped with a spring length indicator to show the proper amount of tension that should be applied when the decks are tensioned, prior to field operation.



NOTE!

For proper tension, the tip of the indicator should be even with the end of the spring. This allows for good draper tension, while still having spring compression left over for crop loads on the draper.

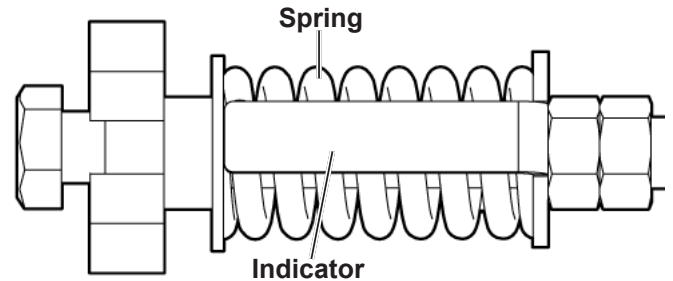

Fig. 98

To check if tensioning is required:

- Engage the windrower drive with the engine at low idle.
- Observe from the cab how the drapers are tracking.



If adjustment is required, lower the swather to the ground, raise the reel and lock in place. Shut down the swather, and turn off the engine before exiting the cab.

If tensioning is still required:

- Adjust the tension by turning the adjuster bolt (Quick Release doesn't need to be released when adjusting).
- Turn the adjuster bolt clockwise (shorten the bolt) to decrease tension, or counter-clockwise (lengthen the bolt) to increase tension.

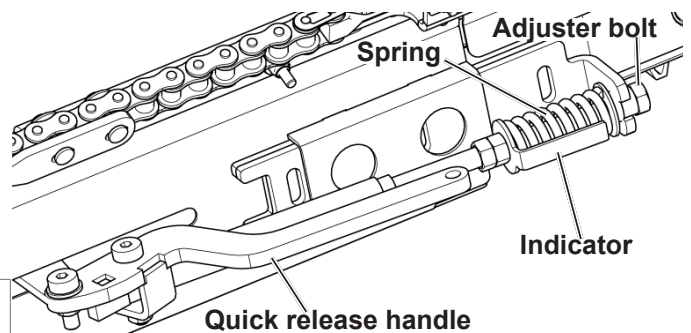

Fig. 99 - Deck Tensioning



NOTE!

When increasing tension, do not compress the spring past the indicator tip.

Restart the windrower and repeat the running test. Re-adjust as necessary.



When adjusting the draper tension and tracking, check the clearance between the draper deck slats and the end strut.



Draper tension should be just enough to prevent slipping. Do not overtighten as it may cause failure to the bearings, draper rollers and/ or draper belts.



The draper may be damaged if it, or deck parts contact the end strut.

A minimum of 2" (50 mm) clearance is recommended. If necessary, loosen the deck restrainer and slide deck over.

8.4 - Tracking

The draper must track properly on the rollers to avoid damage to the drapers. The draper decks allow for approximately 1/4" clearance on each side.

8.4.1 - Drive Roller Tracking Adjustment

This roller is fixed at the cutter bar, so it is adjustable only at the back panel. If the draper is tracking toward the back panel, tighten the nut on the eye bolt (shorten the eye bolt). This will push the idler mount plate and drive roller at the back panel end out, creating more slack in the draper at the cutter bar.

If the draper tracks toward the cutter bar, lengthen the eye bolt. This will pull the idler mount plate and drive roller in, creating slack in the draper at the back panel end.

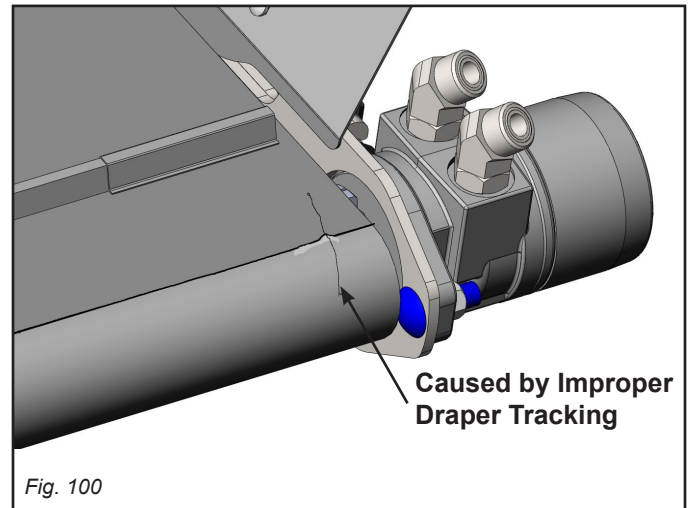
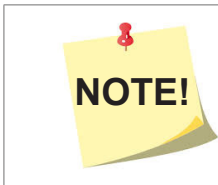

Fig. 100



The draper will track to the slack side.

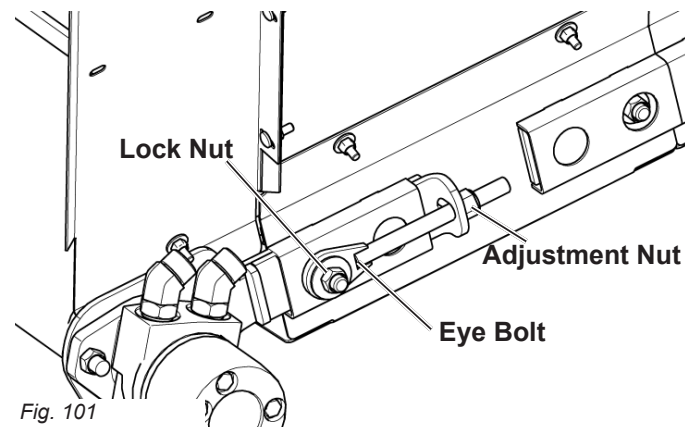

Fig. 101

8.4.2 - Idler Roller Tracking Adjustment

There is no direct adjustment for tracking on the idler roller end. It is self tracking by way of the v-guide in the drive roller and tensioning system

8.5 - Draper Speed

Proper draper speed is critical to the performance of your Swather. The draper speed should be set to match the field speed of the swather and to deliver the material smoothly to the center opening. The speed of the lateral draper is controlled by an adjustable flow control. Adjusting the flow control will affect decks equally. The draper speed flow control is managed from the Honey Bee Switch Box (see Fig. 102).

8.5.1 - Additional Draper Speed

When swathing, the draper speed should be set to form a good windrow, removing material from the cutter bar, and delivering the material smoothly to the opening.

Experiment with various draper speeds to determine the best swath formation for the existing cutting conditions. It may be necessary to make further adjustments as crop and moisture conditions change.



Excessive draper speed will cause abnormal wear, and will shorten the service life of the draper.

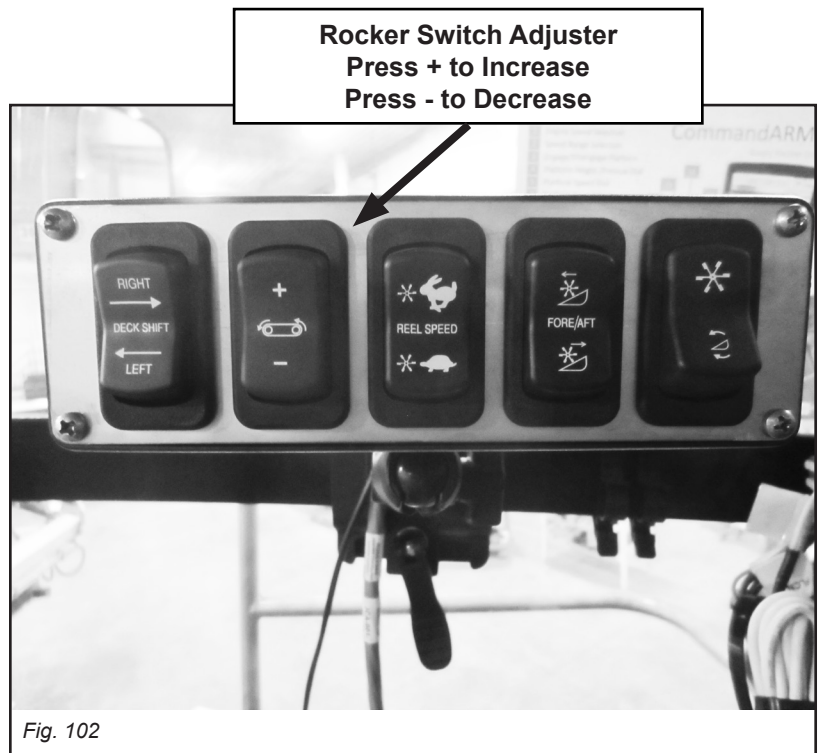

Fig. 102

8.6 - Draper Splicing

Honey Bee Mfg. strives to provide top quality draper material on their products. Our draper is made from rubberized polyester with fiberglass reinforced slats. Regular maintenance will extend the life of your draper. Proper tension and tracking are very important. If material builds up inside the deck, it will wrap around the idler and drive rollers causing the draper to tighten. As the draper tightens, additional stress is put on the motor and the draper. If this condition is not corrected, it will result in failure of the drive roller motor or the draper. Tears in the draper can be caused by poor tracking, foreign materials, or from careless use. If only a portion of draper is damaged, a splice may be installed.

Before beginning this repair, you will need an additional connector bar set and a section of draper that is at least 2 ½" longer than the piece to be removed.



If the damaged section is not near an existing connector bar, you will need 2 connector bar sets and a piece of draper 5" longer than the damaged piece.

1. Raise swather table and install lift cylinder locks. (If this is too high for comfortable access, the table can be set on blocks or lowered to the ground.)
2. Raise the reel and place the locks on the lift cylinders to prevent the reel from falling.



Engage the park brake on the windrower, shut the engine down, and wait for all moving parts to stop before leaving the cab.

3. Release the draper tension.
4. Remove draper connecting bar.
5. Correct the cause of the draper failure.
6. The draper should be cut midway between two slats to provide ample material for the new join. With a measuring tape, measure, and mark a line six inches from a slat on a good portion of the draper. Place a board directly under the line you have marked, to support the section you will be cutting. With a utility knife and a straight edge cut the draper along the marks. This cut must be accurate, and square, to assure that the draper will track properly. Repeat this step on the other side of the damaged area.
7. Lay the piece you have removed flat, and measure the width, then add 3 1/2 inches. The total will be the length of material you require for the splice. (If you need two new connector bar sets, add 5".)

8. To mark the location for holes, measure 1" in from each edge to be joined, and mark a line parallel to the cut edges.
9. On each of these lines, measure 1-1/8" from the front edge of the draper, and make a mark for the first hole.
10. Drill 3/16" holes through each mark.
11. Place the backs of the draper together, lining up these drilled holes.
12. Place a connector bar on each side, line up the holes, and secure with a machine screw and nut.
13. Match up the edges of the draper and drill a hole at the opposite end on the 1" line, using the connector bar as a template. Insert a screw and secure in place. Drill the remaining holes through the holes in the connector bar, insert screws and secure.
14. Adjust draper tension. Trim all joins to 1/2" above connector bar.
15. Adjust tracking.

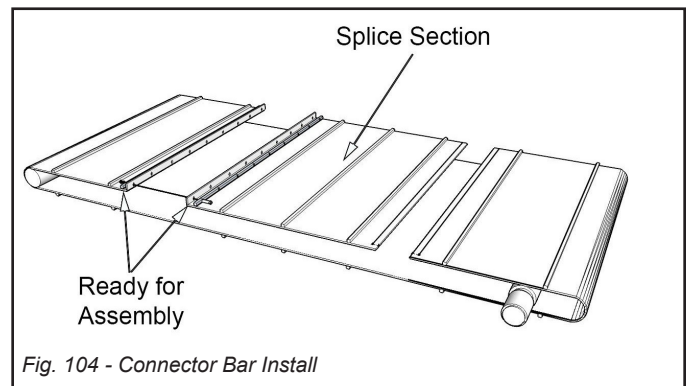
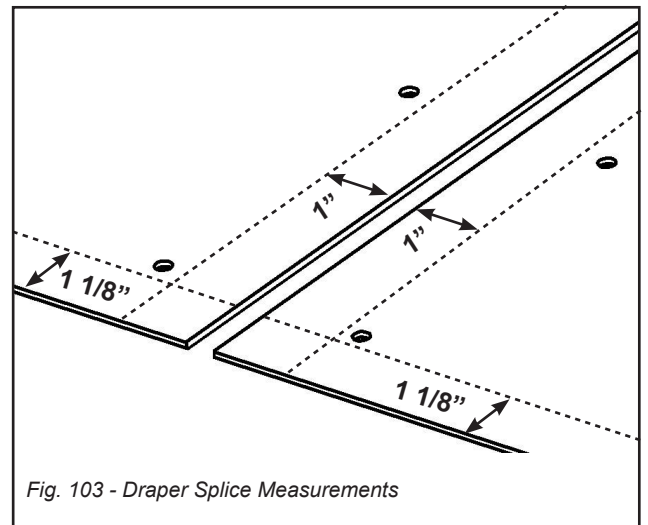

8.7 - Drive Roller Removal

1. Relieve draper tension using the quick release lever.
2. Mark hydraulic hoses on draper motor. Remove hoses. Insert plugs into hoses and caps on the motor to reduce oil loss and to prevent contamination.
3. Remove the lock nuts that secure the motor onto the motor plate. It is not necessary to remove the adjuster bolt from the motor plate.
4. Pull the motor with drive roller through the hole in the motor plate.
5. Check bearing in end of roller, and remove any build up of material on roller.

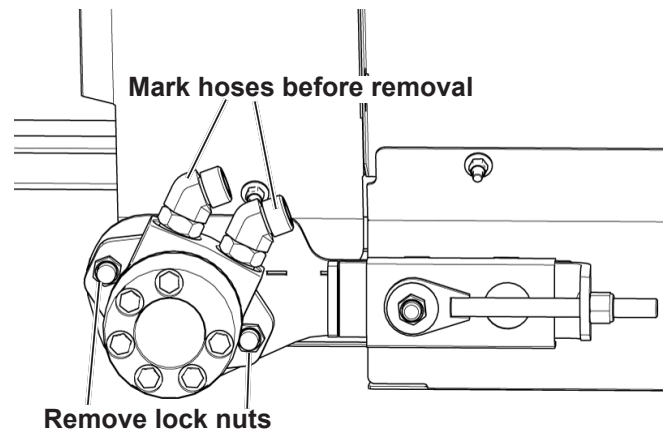

Fig. 105 - Driver Roller Removal



Check and remove any built up material from the draper deck runners. If necessary, split draper at connector bar to gain access to inside of the deck.

To re-install drive roller, reverse above procedure. Adjust tension and tracking as necessary.

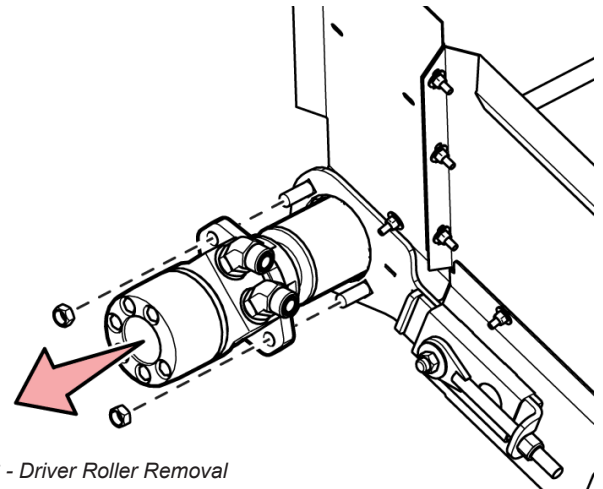

Fig. 106 - Driver Roller Removal

8.8 - Removing Draper Motor

1. Remove Hex Bolt set screws.
2. Insert two pry bars one on each side of motor, and pry motor out of drive roller. Do not hammer on the housing flanges of the motor. Damage to motor will void warranty.
3. If motor does not move, insert a 7/8" or 3/4" rod through the center of drive roller and apply force directly to the shaft of the motor.

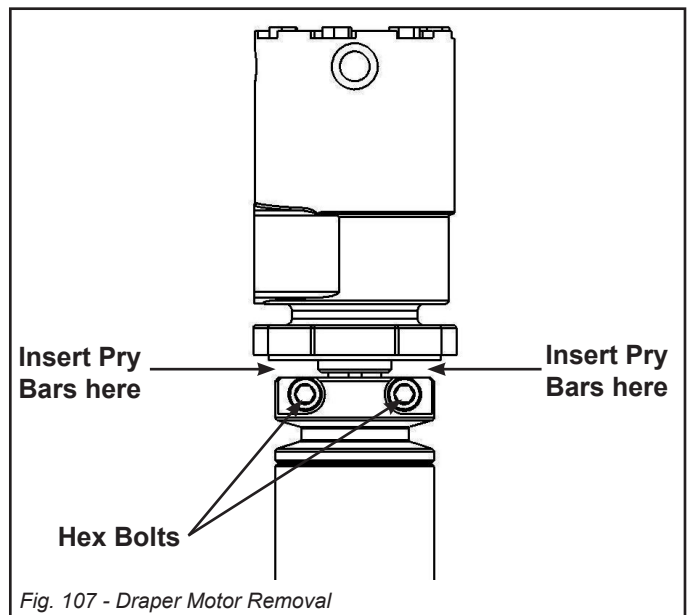
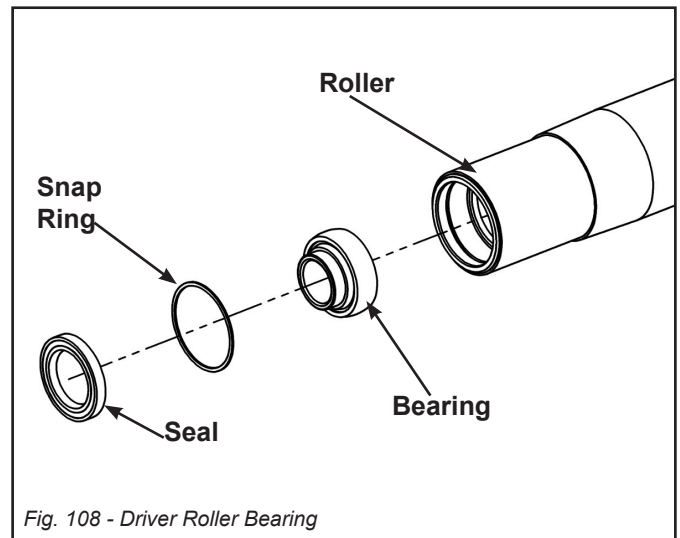

Fig. 107 - Draper Motor Removal

8.9 - Replace Bearings on Drive Roller

The roller bearings are pressed into the rollers with a friction fit and held in place with a retaining ring.

1. Remove seal that holds the bearing assembly in place. Be prepared to replace the seal with a new one upon replacement.
2. Remove the snap ring that secures the bearing in place.
3. On the opposite end of the roller from the bearing to be removed, insert a small rod through the inside of the roller and push the bearing out.
4. Drive bearing out with the rod.
5. Install new bearing, and replace the retaining ring and seal.



8.10 - Installing Draper Motor

1. Clean motor shaft and hub of drive roller. Apply anti-seize to shaft.
2. Insert key in motor shaft.
3. Insert motor into hub, lining key on shaft with the key-way in the hub. Do not use a hammer on housing flange; damage of this nature to the motor will void warranty. Use a soft blow or rubber hammer to apply force to end of motor.
4. Tighten set screws.

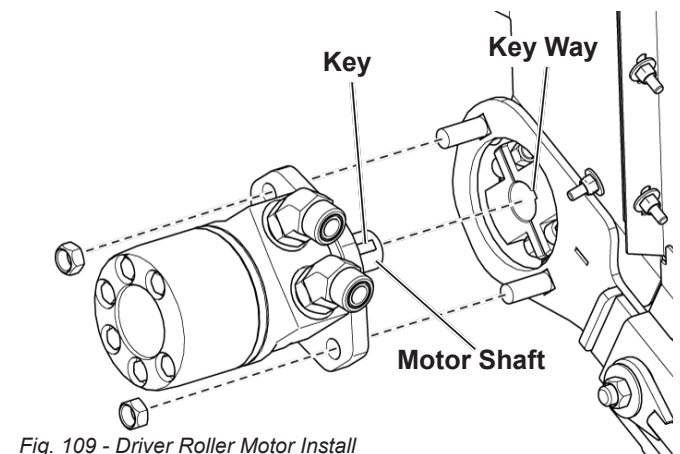

8.11 - Idler Roller Removal

1. Relieve the draper tension using the quick release lever located next to the idler roller.
2. Remove the bolt securing the tensioner to the sway bar as shown in Fig. 110 on page 68. This will allow you to slide the tensioner assembly partially out of the c-channel far enough to remove the roller.
3. Remove the roller and check bearing in end of roller, and remove any build up of material on roller.

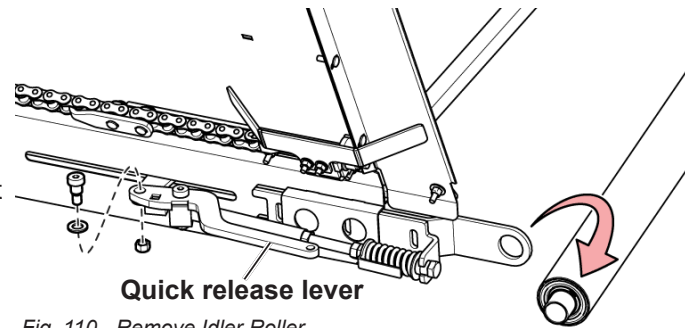

Fig. 110 - Remove Idler Roller

8.12 - Replace Bearings on Idler Rollers

The roller bearings are pressed into the rollers with a friction fit and held in place with a retaining ring.

1. Remove seal that holds the axle and bearing assembly in place. Be prepared to replace the seal with a new one upon replacement.
2. Remove the snap ring that secures the bearing and axle in place.
3. Grab the axle and pull it out of the roller, ensure that you pull the side with the hexagon end out first.
4. On the opposite end of the roller from the bearing to be removed, insert a small rod through the inside of the roller and push the bearing out.
5. Install new bearing, and replace the axle, snap ring and seal.

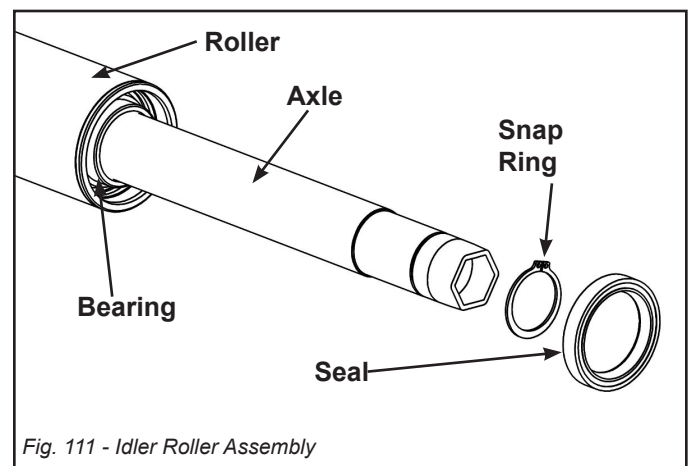

Fig. 111 - Idler Roller Assembly

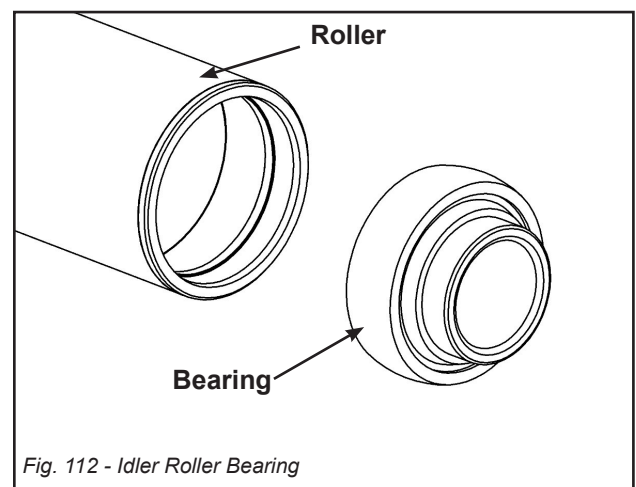

Fig. 112 - Idler Roller Bearing

8.13 - Draper Deck Maintenance:

1. Remove draper connector bar.
2. Remove draper - clean draper of debris, both sides.
3. Store draper indoors.
4. Clean debris from rollers, deck channels, and runners.
5. Check and bend down corners of deck runners so draper does not get caught.
6. Clean adjusters; lubricate guide tubes and adjuster tubes. Adjusters should move freely inside the guide tube.
7. Check idler roller bearings; they should spin freely.
8. Check drive roller bearings.
9. Check bearing stubs.

**NOTE!**

If you elect to store the swather outside with draper installed, position the connector bar on the underside to aid water drainage. Ice build-up underneath could cause draper to sag and drop out of the lower runner. If this is not noticed and corrected, damage may occur to draper on start-up.

8.14 - Draper & Reel Maximum Speed Adjustment

Draper and reel speed is controlled via the switch box in the windrower cab. The maximum speed that can be achieved via the controls in the windrower is restricted by the priority flow cartridge on top of the hydraulic manifold located on the center rear of the swather as shown in Fig. 113. The maximum speed is preset in the factory and should only be adjusted if instructed to do so by the manufacturer or dealer.



Ensure that all equipment is shut down and has stopped moving before attempting to adjust the maximum draper and reel speed.

To adjust maximum draper and reel speed:

1. Locate the priority flow cartridge on the top of the manifold block-“A508 269” Port (see Fig. 113).
2. Loosen the lock nut on the cartridge.
3. Adjust the set screw in half-turn increments as required:
 - Turn clockwise to increase speed.
 - Turn counterclockwise to decrease speed
4. After each half-turn, tighten the lock nut, restart the equipment and check the draper and reel speed. If more adjustment is required, ensure the equipment is turned off.



Adjusting the set screw only sets the maximum speed limit.

The pump flow is set by the windrower controls.



To set this cartridge, loosen the nut and turn the screw all the way in, then turn it out four full turns and re-tighten the nut.

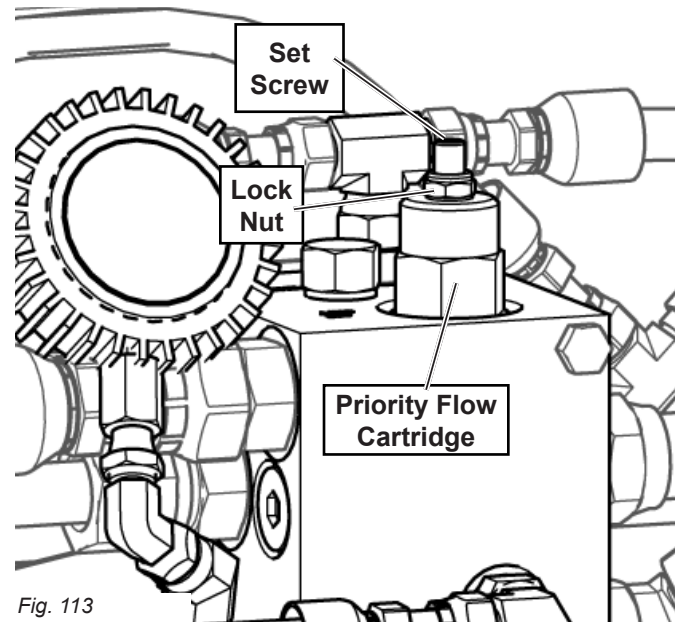

Fig. 113

9 - Cutting System

All cutter bar components must be maintained in good condition to obtain acceptable field performance. Inspect the cutter bar daily for damaged and broken parts before starting work. Repair or replace parts as required.



When working with or around the knife, take the following precautions to avoid death or serious injury:

- Raise the table, raise the reel, stop the engine, set the park brake, and remove the ignition key.
- Wait for all moving parts to stop before dismounting.
- Install the reel and table lift cylinder locks.
- Clear the area of bystanders, especially children.
- Wear heavy canvas or leather gloves when working with the knife.

9.1 - Knife Speed

See section *11.6 on page 83*

9.2 - Removing the Knife

Remove the two socket head cap screws (1) on the knife head block. Slide the knife out of the cutter bar.

Reverse the procedure when installing the knife. Apply a small amount of thread lock solution to cap screws (1) before installation. Torque to recommended specifications - 59 ft-lb (80 Nm).

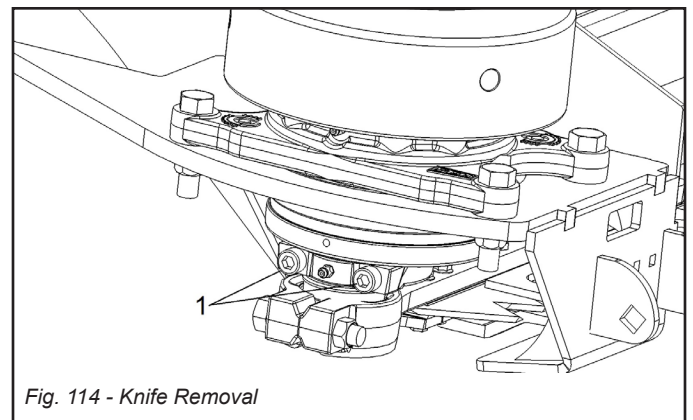

Fig. 114 - Knife Removal

9.3 - Guards

When replacing guards always mount the new guard with the SCH stamp to the top. Be sure the spacer bar is on top of the cutter bar. The crimp-lock nut on the guard bolt should always be on top.

Alignment is critical. Before tightening the guard bolts, push the spacer bar as far back on the cutter bar as possible and pull the guard ahead as far as possible. Sight down the cutter bar to be sure the guards are aligned. Tighten guard bolts.

9.4 - Sickle Sections

The sickle sections of the knife are installed with alternating cutting surfaces. One section will have the cutting surface on the top and the next will have the cutting surface on the bottom. They must be in good condition to obtain proper cutting.



Always alternate the sickle sections, one with the serrations facing up, the next, facing down.

Replace a Section:

- | | | |
|--|----|---|
| <ol style="list-style-type: none">1. Remove the guard to expose the section.2. Unbolt the section and install a new one.3. Tighten the section bolts and nuts.4. Install the guard. | OR | <ol style="list-style-type: none">1. Turn the knife by hand until one section bolt is exposed.2. Remove the bolt.3. Turn the knife until the other bolt is exposed.4. Remove it, and install a new section by reversing this procedure.5. Tighten section bolts and nuts. |
|--|----|---|

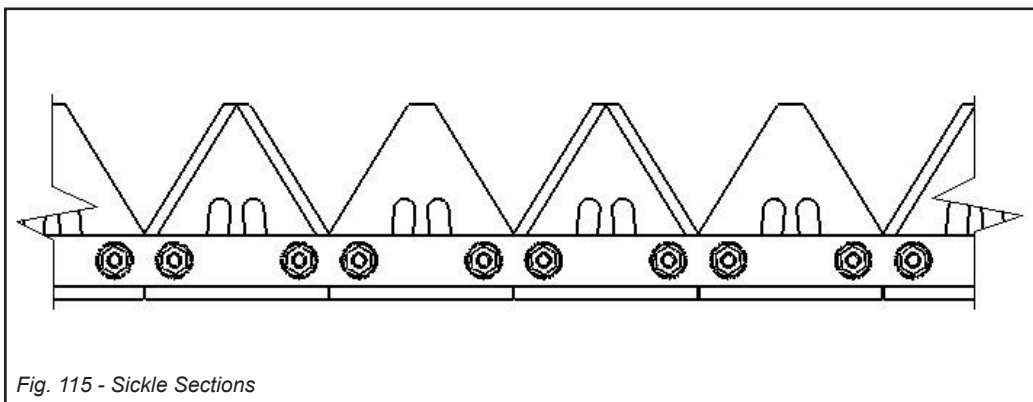

Fig. 115 - Sickle Sections

9.5 - Knife Drive/Knife Head

Proper maintenance of the knife drive and the knife head is critical to the performance of your swather.

Check the knife drive hold down bolts daily. Tighten to the specified torque as needed.

Check the knife head bearing daily. If the bearing is loose, check the tightness of the bolt. If the bolt is tight, check the condition of the bearing and sleeve. If any parts are defective, replace them immediately to avoid damage to the drive.

Check the knife head locking bolt and the socket head cap screws daily. Rotate the knife drive by hand after tightening the knife head bolt to be sure the bearings rotate freely.



NOTE!

Knife drives should always rotate counter-clockwise to keep the bottom cap screw from coming loose.

Check the knife head bolts which attach the knife head to the knife back daily. The bolts should be tightened to 120 in lbs., (13.5 Nm), (9.96 ft lbs.)

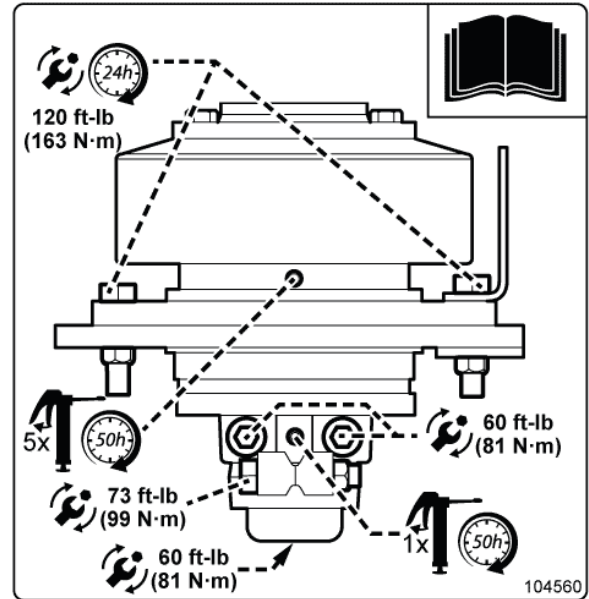

Fig. 116 - Knife Drive Detail

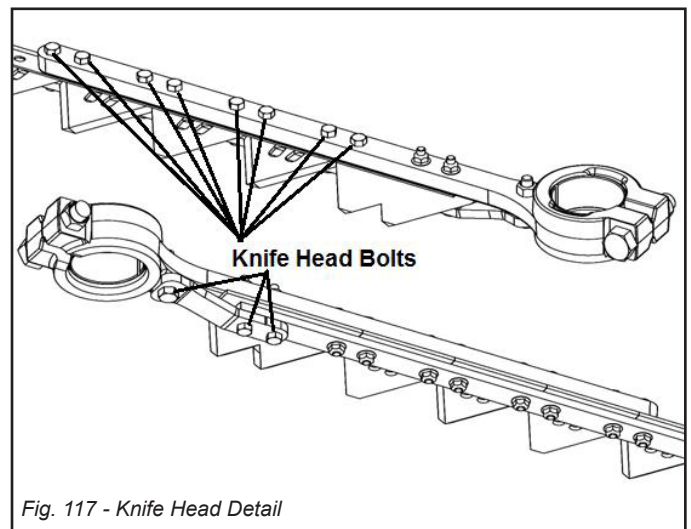
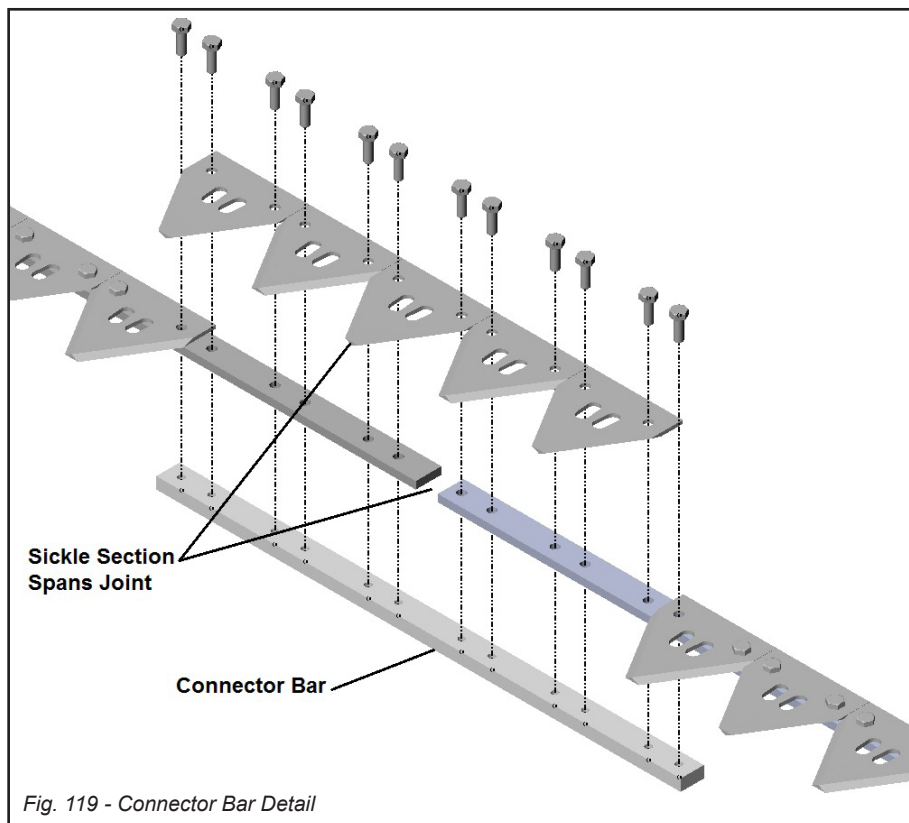
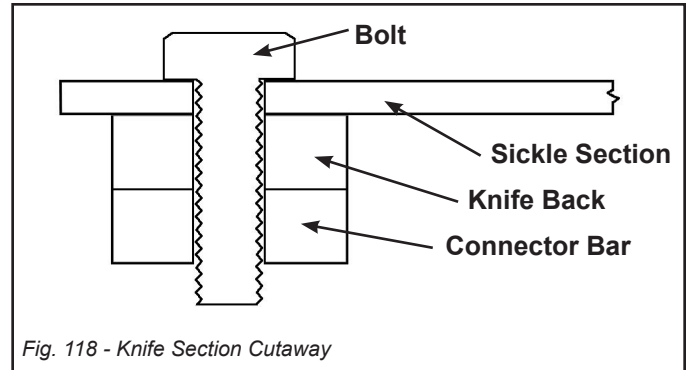

Fig. 117 - Knife Head Detail

9.6 - Connector Bar

On some models of Honey Bee swathers a connector bar is used to join two sections of knife back. The sickle sections are bolted to the knife back. The connector bar is attached to the underside of the knife back with eight threaded inserts installed into the bar which protrude slightly on the side that contacts the knife back. The knife back is punched with slightly tapered holes to accommodate the sickle sections.

The knife sections must be installed on the top side of the knife back (the side stamped "TOP") so that the protruding inserts of the connector bar will fit snugly into the tapered section holes. As the section bolts are tightened, the inserts in the connector bar are drawn into the knife back forcing them to clamp down on the bolt. The bolts should be tightened to 115 in-lbs, (13 Nm).



Do not grind the inserts flush with the connector bar. This will defeat their function, and may cause a knife failure. Check tightness of bolts daily; replace broken and worn sections as required.

9.7 - Overlap Kit

The overlap kit is used on swathers equipped with double knife drives. The fasteners in the overlapping portion of the knife are countersunk to provide a smooth-sliding surface. The overlap guards are open on top, and are deeper to provide room for the double thickness of the knife. The overlap strap bolted to the left-hand knife will slide over the countersunk sections where the knives overlap. If knives are noisy or are over heating, check to see if the overlap guards have been properly installed.

The knife sections that are on the overlap strap and the right hand knife back need to be snugged down to the back up bar when the countersink bolts are tight.

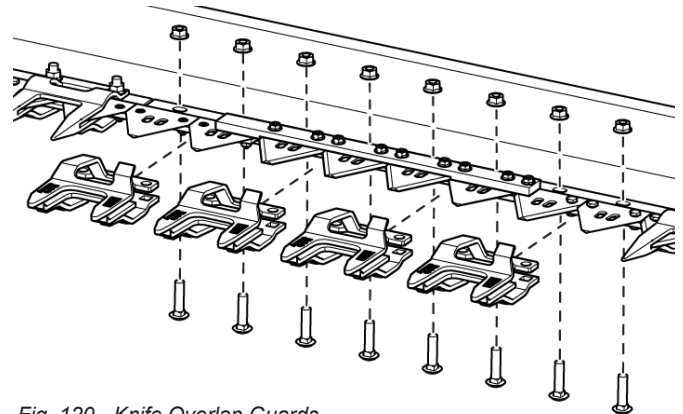

Fig. 120 - Knife Overlap Guards

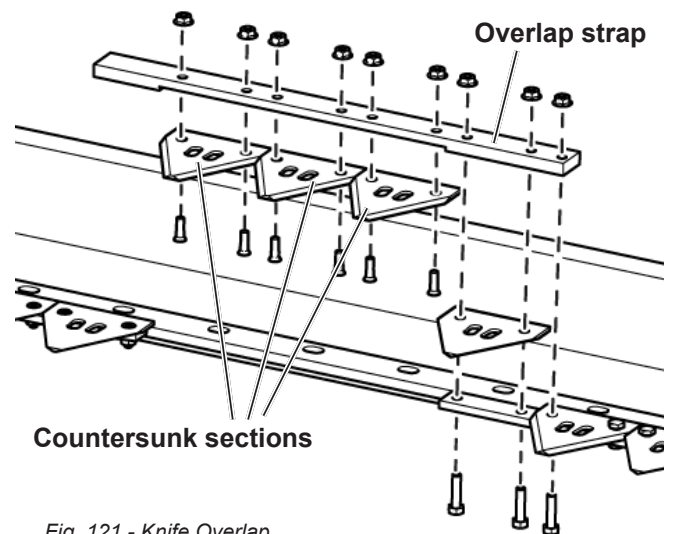

Fig. 121 - Knife Overlap

If the sections are loose:

1. Remove the countersink bolts.
2. Inspect the holes drilled into the knife back or overlap strap for a countersunk depression. This allows the tapered head of the bolt to draw down fully, seating in the knife section.
3. If no countersink is found, drill them in (about 1/32" deep) with a 9/32" drill bit.

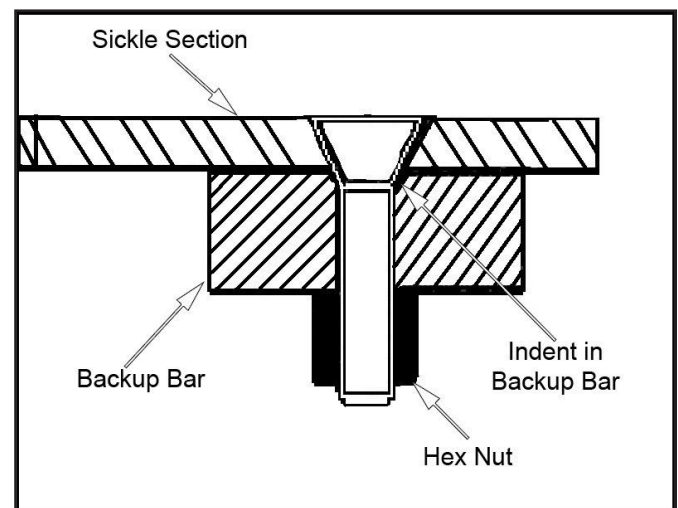



Fig. 122 - Knife Back Insert

9.8 - Repair Broken Knife Back

If the knife breaks during use, repairs can usually be made using a connector bar. Typically, the knife back will break across a sickle section bolt hole. The damaged section needs to be cut out and/or a section of knife removed. If the knife breaks close to the knife head end, remove that section of knife, reconnect the knife head, then add the new piece to the far end of the knife where there is less mechanical stress on the knife.

The join must be directly under the center of a sickle section, not where two sickle sections join.

Inspect the knife for dull/damaged guards and sections and built up crop residues. These are the most common causes of knife breakage.

	Correct any of these cause factors before resuming operation.
---	---

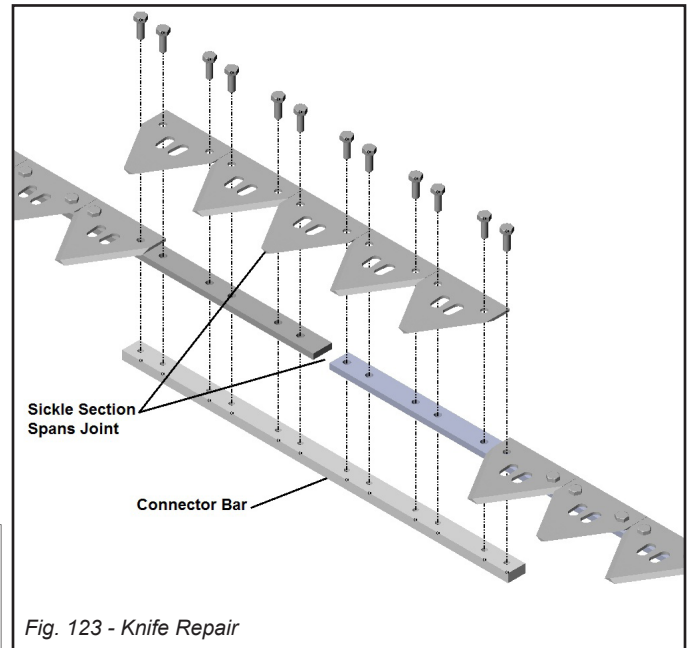

9.9 - Knife Speed Sensor

The table is equipped with a sensor, located on the knife drive motor, which provides the ability to monitor and calibrate knife speed.

The sensor should be positioned so that there is a gap of 1/16" between the pulse wheel and the sensor.

9.10 - Monitoring Knife Speed

Knife speed can be displayed on the CommandTouch Corner Post of the Windrower. It will be seen as Platform Speed. Optimal Knife Speed is preset to 720 rpm.

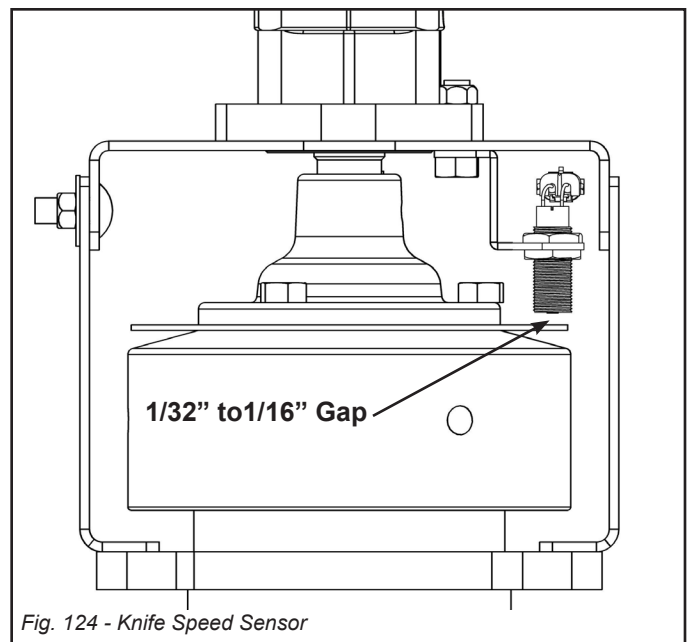

10 - Leveling

10.1 - Forward Angle Adjustment – Hydraulic Tilt Cylinder

Once all the proper hydraulic connections are made, you can tilt the table by setting the Honey Bee Switch Box to Tilt (see Fig. 125), and then using the Tilt Button on the Multi-function Lever (see Fig. 126).

10.2 - Table Angle (Tilt)

The views of the windrower and table at the bottom of this page show the results of adjustments to the tilt cylinder.

Fig. 127 shows the tilt cylinder fully retracted, drawing the top of the table back. The draper decks will run more horizontal to the ground.

Fig. 128 shows the tilt cylinder fully extended, tilting the table forward. The draper decks will run at a steeper angle to the ground.

Remember that the above examples represent the extreme range of adjustment.

Experiment within this range of adjustment to determine the best setting for your operating conditions and for the type of swath you want.

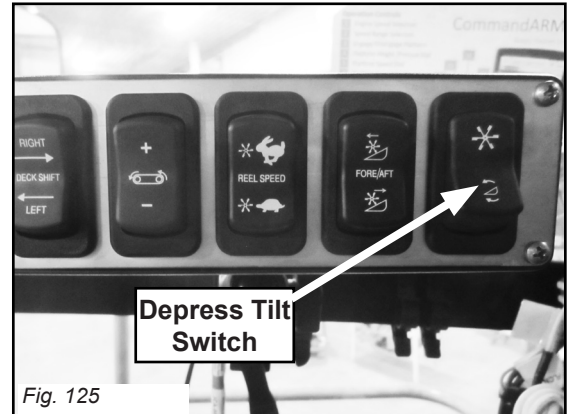

Fig. 125



Fig. 126



NOTE!

In rocky conditions, with a short crop, it may be beneficial to keep the guard tips up. Try shortening the tilt cylinder. In bushy crops, such as mustard, you may want to tip the swather forward to maximize the opening.

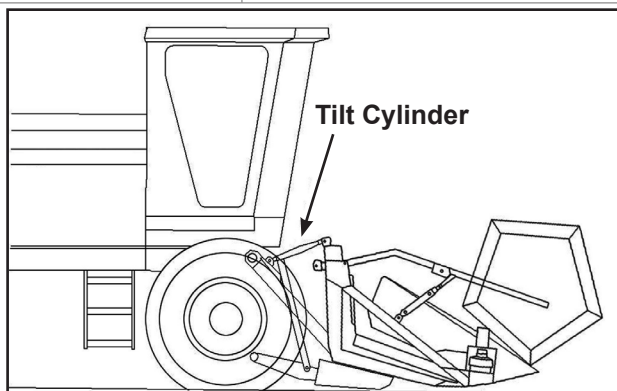

Fig. 127 - Tilt Cylinder Retracted

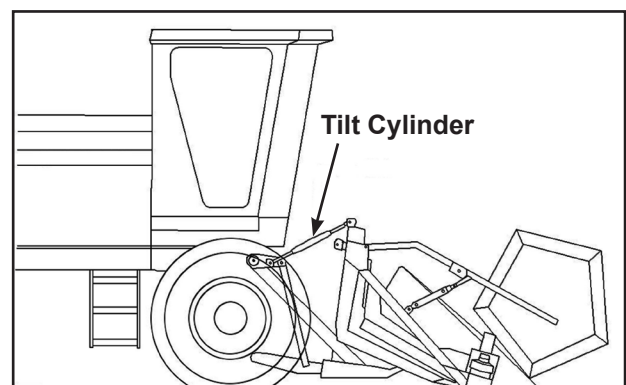

Fig. 128 - Tilt Cylinder Extended

10.3 - Adjusting Independent Table Floatation

The Windrower Floatation Feature allows the operator to tilt the Honey Bee Swather Table laterally to match the terrain that they are cutting on, or to level the table due to weight imbalance.

See the windrower operator manual for details on adjusting table floatation.

The chart below shows approximate Float Settings for the different sizes of Honey Bee WSC Swathers. You will want to adjust the settings for your specific situation. Addition of equipment options will require different settings.

TABLE SIZE	SUGGESTED PRESSURE
15 ft	1200-1300 psi (83 - 90 bar) (8274 - 8963 kPa)
25 ft	1400-1500 psi (97 - 103 bar) (9653 - 10342 kPa)
30 ft	1500 – 1600 psi (103 - 110 bar) (10342 - 11031 kPa)
36 ft	1600 – 1700 psi (110 - 117 bar) (11031 - 11721 kPa)

10.4 - Setting the Cut Height

The cut height is a combination of three settings:

- Flotation pressure for the lift arms.
- Tilt angle for the header
- Gauge wheel setting

Start with setting the gauge wheels all the way up (see 12.2 on page 85) then set the flotation pressure to the values mentioned in the table from the previous section based on your table size, then drop the header down using the drop header button on the MFH,



Fig. 129

If the height of the cutter bar is not what you want, change the flotation pressure up or down to get the desired cut height, then adjust the gauge wheels as mentioned in section 12.2 on page 85.

Note: These gauge wheels are available for sizes 30 & 36 ft only. for 15 & 25 ft use the end strut gauge wheels to support the header and to set the cut height along with the flotation pressure.



NOTE!

You can use the header tilt angle to make fine adjustments to the cut height and not for major settings.

11 - Hydraulics

The Swather uses windrower hydraulics to power its systems. Hydraulic pressure flows to the manifold block, which regulates the flow by sending the primary flow to the 50/50 flow divider, which splits the flow equally between the draper and reel circuits. The secondary flow is directed to the knife drive. The system is protected by a pressure relief valve which should be set to 3000 psi. Return-flow oil is filtered before returning to the windrower.

See section 16.3 on page 109 for hydraulic schematics

11.1 - Manifold Block Cartridge Locations

Identification stamps can be found on individual parts as well as port stamps on the Manifold Block itself.

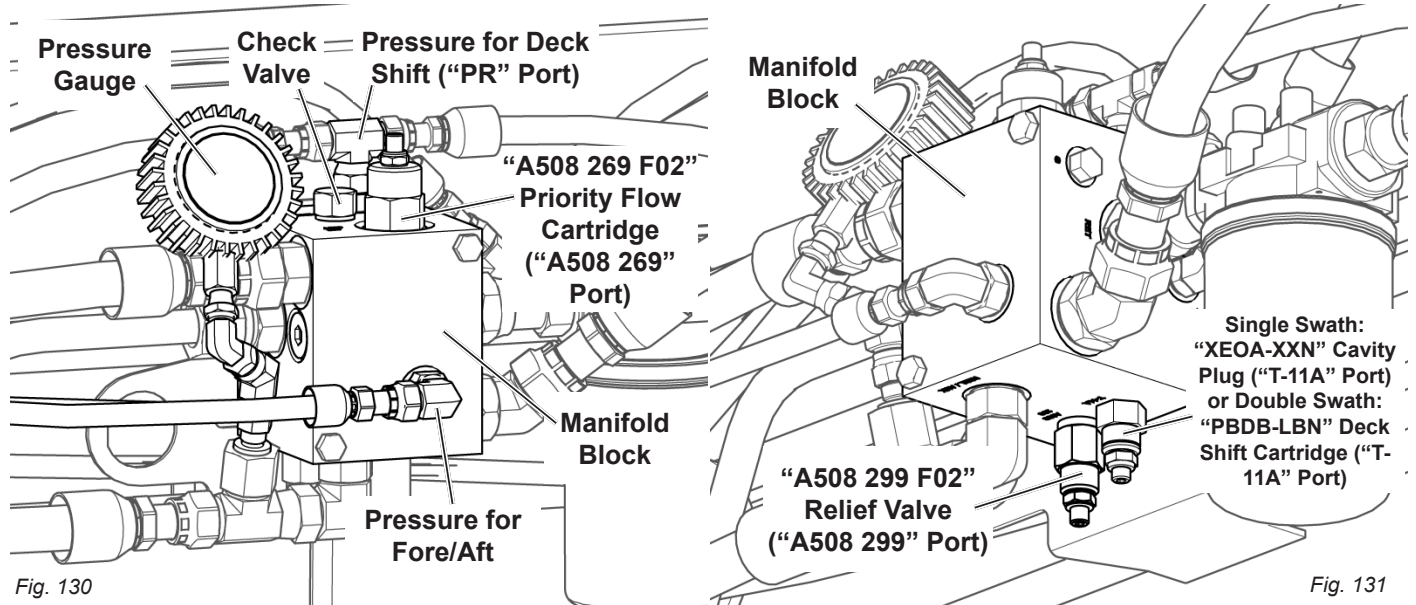

11.2 - Flow Controls

An 11 GPM (41.6 LPM) flow control is used for the drapers, while an 18 GPM (68.1 lpm) flow control is used for the reel. The "R" (control flow) port of the draper flow control goes to the draper motors. The "R" (control flow) port of the reel flow control goes to the reel motor. The "T" (excess flow) port of both flow controls diverts oil directly to the return circuit.



The windrower relief valve is set to 5000 psi. Care must be used when working around pressurized hydraulic systems.

Quick couplers must be securely connected before the windrower is started, and power is applied to the swather. Serious injury, and/or damage to equipment may result from poor connections.

11.3 - Hydraulic Connection Points

Connect the hydraulic hoses from the swather shown below to the windrower.

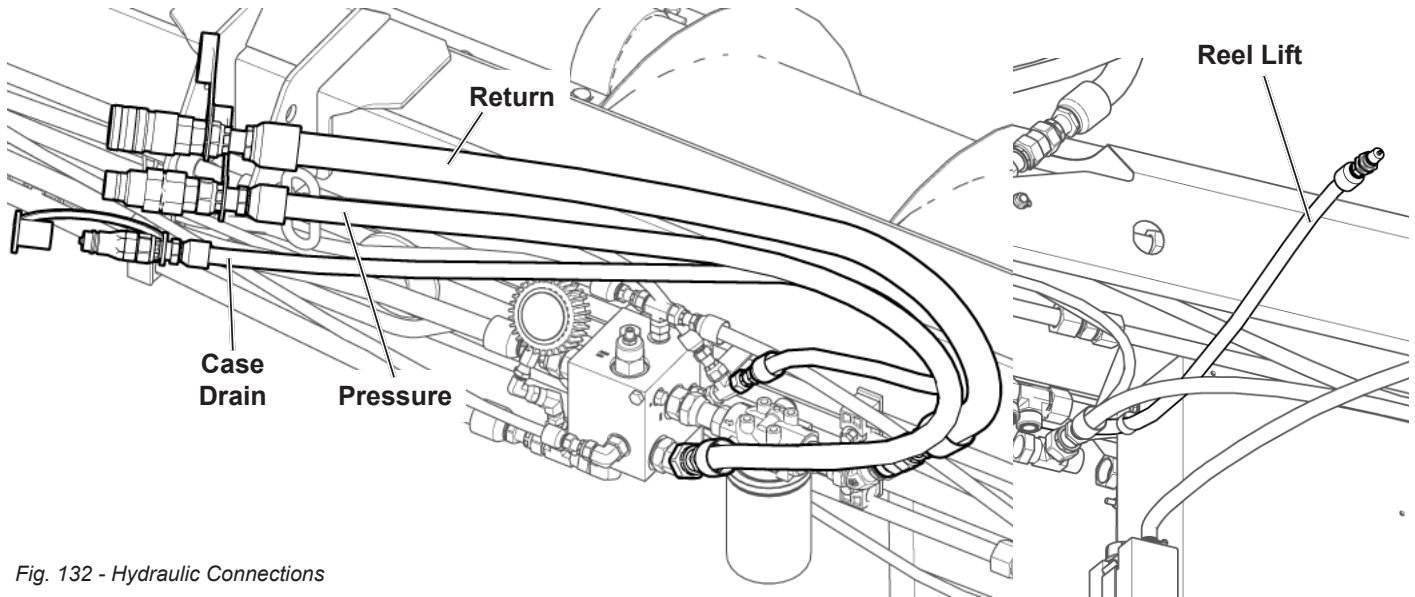

Fig. 132 - Hydraulic Connections

11.4 - Operating Pressure - Knife Circuit

The pressure gauge, located beside the manifold block, indicates the total hydraulic pressure required to run the knife. Normal operating pressure should range between 1200 and 1700 psi for double knife when the windrower is operating at normal working rpm, and the oil is at operating temperature.

It's normal for pressure to fluctuate while cutting, due to crop conditions. Other factors that will affect pressure include the condition of the cutting system, and ground speed.

11.5 - Checking or Adjusting Knife Relief Pressure



Set the park brake, shut the engine down, and wait for all moving parts to stop before leaving cab.

Be certain all bystanders are away from the machine prior to engaging the pump. Only stall the knife long enough to obtain accurate readings. Prolonged operation in this condition could cause damage.

1. Jam a wood block tightly in the knife, between a guard and cutting section.
2. Restart windrower. Raise the reel, and insert the cylinder lock.
3. Engage the hydraulic pump drive, bring the engine rpm to the normal working range, and check the pressure on the gauge. If the reading is 3000 psi, shut the windrower down, remove the wood block, and reel cylinder stop.

If adjustments are required, shut the windrower down, and continue with the following:

4. Locate the relief valve on the left side of the header (**see Fig. 133**). Adjust the relief screw; turning clockwise increases pressure, and counter-clockwise decreases pressure setting.
5. With the knife jammed as described previously, restart the windrower, engage the hydraulic pump drive, and re-check the pressure reading.

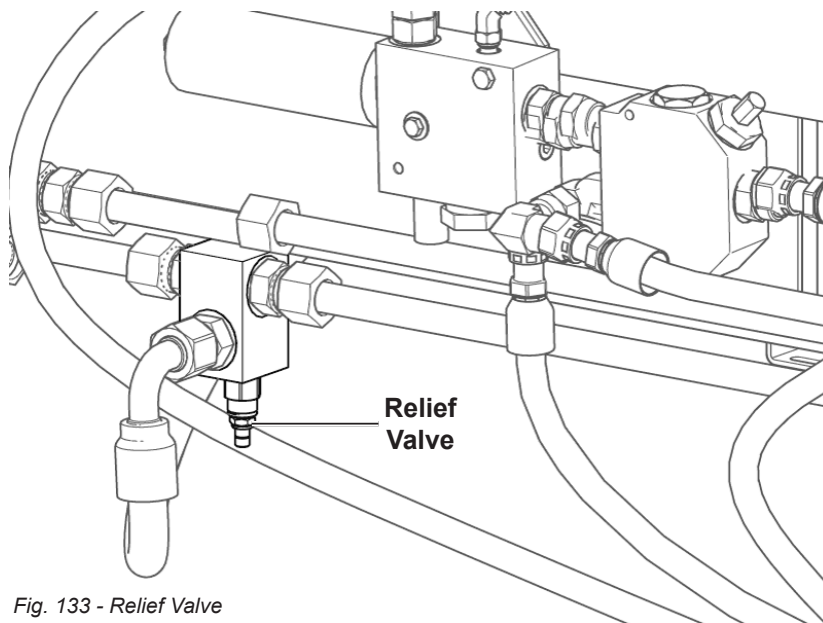

Fig. 133 - Relief Valve

11.6 - Knife Drive Speed Adjustment

Knife speed is adjusted via the windrower's controls. The optimal knife speed is 720 RPM, it is suggested that you not change this setting.



Increasing the knife speed beyond 720 RPM increases the chance of extra wear, additional breakage and/or damage to the cutting system.



Ensure that all equipment is off and has stopped moving before attempting to adjust the knife speed.

Do not adjust the knife speed beyond 720 RPM.

11.7 - Draper and Reel Flow Controls

The draper circuit flow control is located on the upper tube on the left-hand end of the table (see Fig. 134).

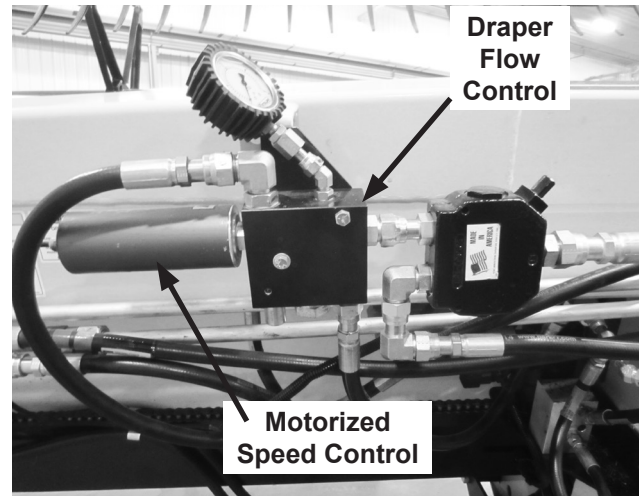

Fig. 134 - Draper Speed Control

The reel circuit flow control is located on the side of the strut on the right-hand end of the table (see Fig. 135).



NOTE!

Both flow controls are equipped with a tamper-proof preset relief valve and a motorized speed control. Each relief valve is preset at 3000 psi (206.9 bar) and is non-adjustable. Each speed control is electrically adjustable by corresponding draper speed and reel controls in the cab.

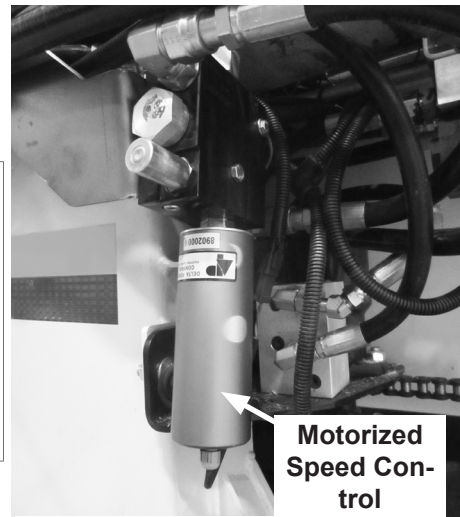

Fig. 135 - Reel Speed Control

11.8 - Return Line Filter

This filter cleans the oil as it returns to the windrower. Change this filter after the first 50 hours of operation, and seasonally thereafter. The OEM filter is a Donaldson P164375. A partially plugged oil filter can adversely affect the flow of oil in the system.

See section 16.10 on page 119 for a list of compatible replacement filters.

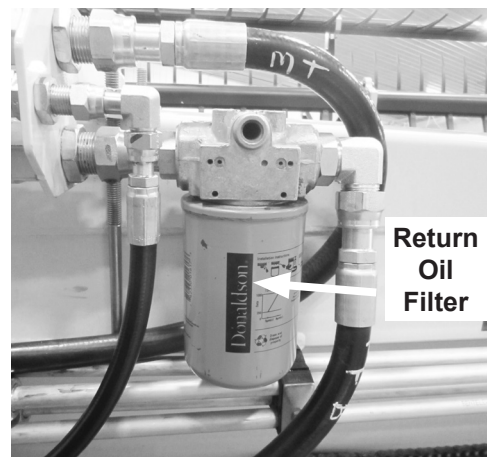



Fig. 136 - Return Oil Filter

12 - Optional Equipment

12.1 - Caster Gauge Wheels

Gauge wheels enhance the table's ability to follow the profile of uneven ground. In the cutting position, especially in short or "down" crops, this can be essential. The gauge wheels are designed to swivel, making it unnecessary to raise the swather when cornering.

 <p>IMPORTANT</p>	<p>Damage to the gauge wheels could result if header and gauge wheels are not lifted clear of the ground when backing up.</p> <p>Damage to castor wheels can also result from making tight turns. The sharp turning capabilities of some combines can cause one of the wheels to be dragged backwards.</p>
---	--

 <p>NOTE!</p>	<p>The swather should be leveled and parked on level ground before attempting to adjust gauge wheel height.</p>
---	---

Gauge wheels must be adjusted relative to the height at which the swather will be operated in the field.

Normal adjustment would allow the weight of the swather to compress the spring shaft of the gauge wheel assembly by 1.5" (38mm) to 2" (50mm).

 <p>IMPORTANT</p>	<p>Excessive compression of the Shock Assembly will cause stress and premature wear in the top link.</p> <p>Adjustments to table tilt, spring flotation, and pitch will affect the amount of compression in the Shock Assembly. Check shock shaft exposure, and adjust accordingly, after any of these adjustments.</p>
---	---

 <p>IMPORTANT</p>	<p>Remember, the Gauge Wheels are NOT designed to support the full weight of the swather! Their purpose is to help guide the table over variations in ground level.</p>
--	---

12.2 - Gauge Wheel Height Adjustment

1. Fully retract the gauge wheel jack, the pointer should be at or above the "1" mark.
2. Adjust the swather height until the cutter bar is at the desired average cutting height for the crop being cut, i.e. stubble height.
3. Lower the gauge wheel assembly to the ground using the screw jack until the Spring Shaft is compressed by 1.5" (38mm) to 2" (50mm). Repeat this procedure on the other gauge wheel assembly.
4. Confirm that the spring shaft of the gauge wheel assembly is compressed to the specified 1.5" (38mm) to 2" (50mm) range. If incorrect, repeat steps (1-4) as described.

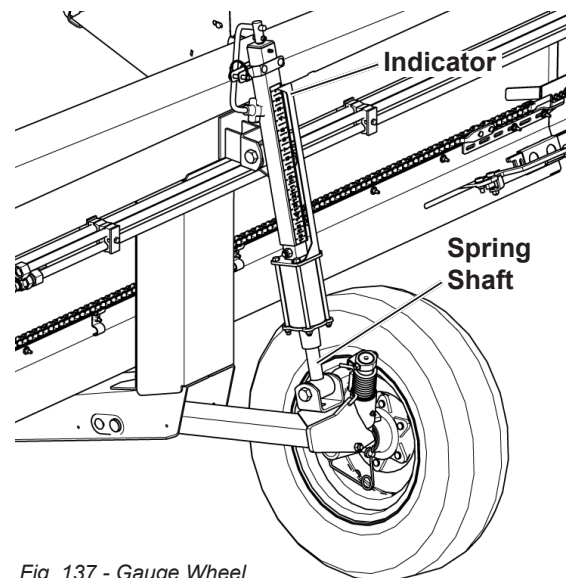

Fig. 137 - Gauge Wheel

12.3 - End Strut Gauge Wheels

End strut gauge wheels are mounted at the outboard ends of the main table frame to enhance the ability to closely follow the contour of the ground with the cutter bar.

Holes drilled in the wheel mount provide height adjustment by relocating the axle shaft as needed.



The draper decks will need to be moved to allow **at least 1"** of clearance from the end strut gauge wheels.

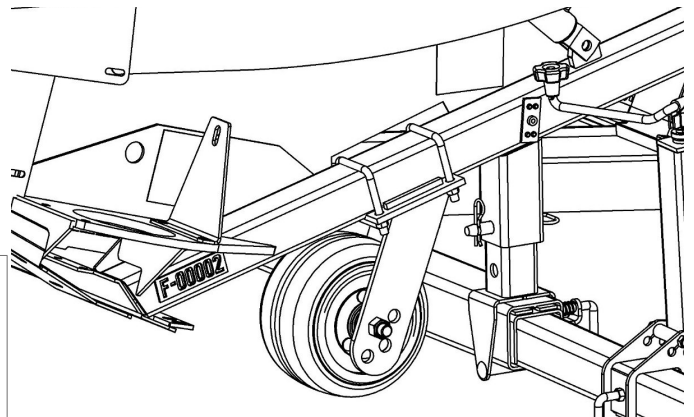

Fig. 138 - End Strut Gauge Wheel

12.4 - Cross Auger

The optional cross auger should be adjusted so the flighting engages the crop to help move it towards the feeder deck opening.

The adjustment jacks are used to change how far the cross auger is extended. The lock bolts can be loosened to allow the angle of the cross auger to be adjusted. Always tighten the lock bolts after adjustment.

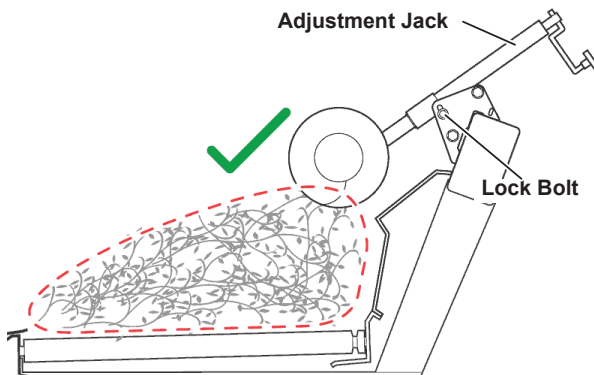

Fig. 139 - Adjust hold-down clearance to cutting section

- Keep a minimum of 3/4" of space between the cross auger and back panel to avoid contact.
- Keep the cross auger close enough to the back panel to avoid crop wrapping, caused by overextending or over adjusting the cross auger angle. If wrapping continues to be a problem, the center paddles can be removed from the cross auger.

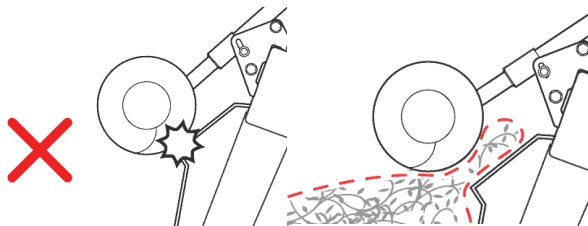

Fig. 140 - Cross auger impacting back panel

Fig. 141 - Crop wrapping around cross auger

- Ensure the center reel arm braces do not contact the cross auger.

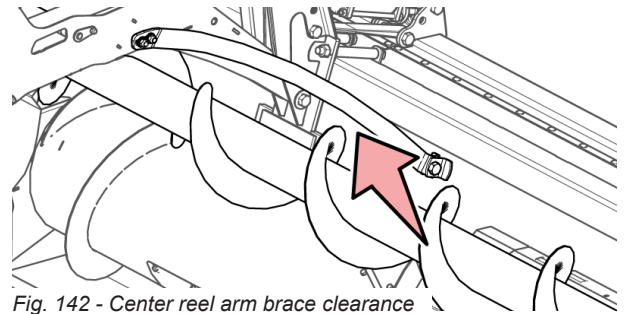

Fig. 142 - Center reel arm brace clearance

The speed of the cross auger can be adjusted via the flow control located on side of the hydraulic manifold as shown below. There is a mechanical limiter to the flow control limiting the range from 1-4, with 1 being the slowest and 4 being the fastest.

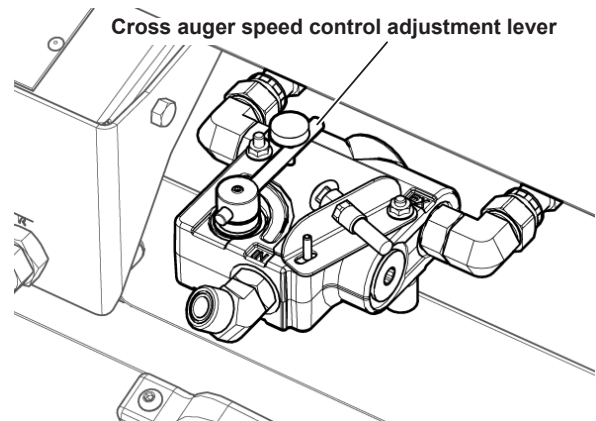

Fig. 143 - Cross auger flow/speed control

WARNING!

Do not bypass the mechanical speed limiter. Setting a speed higher than 4 can result in equipment damage or injury.

12.5 - Double Swath Option – 30ft and 36ft Tables Only

Honey Bee Swathers can be equipped with a double swath option. This option allows the operator to lay two swaths. The first swath will be delivered to the opening on the right end of the swather. On the next round, the decks can be shifted to the right, creating an opening on the left end of the swather. This places the second swath beside the first. This option is useful in light crop conditions.

The decks are shifted using hydraulic motors on a chain and sprocket assembly.

The reverser valve (see Fig. 145) reverses the flow through the output ports when activated. The valve is located under the Left Side Hydraulics Shield.

The deck shift and the draper reverser are electrically controlled in parallel, so that when the deck arrives in its new position, the deck shift motor stops and the draper motor will be running in the opposite direction.

The deck shift roller chains are located on the back of the rear panel (see Fig. 146).

Adjuster bolts at either end of the chain are used to adjust tension.

The chains should not have too much slack, nor should they be too tight.

Excess tension will cause the decks to warp.

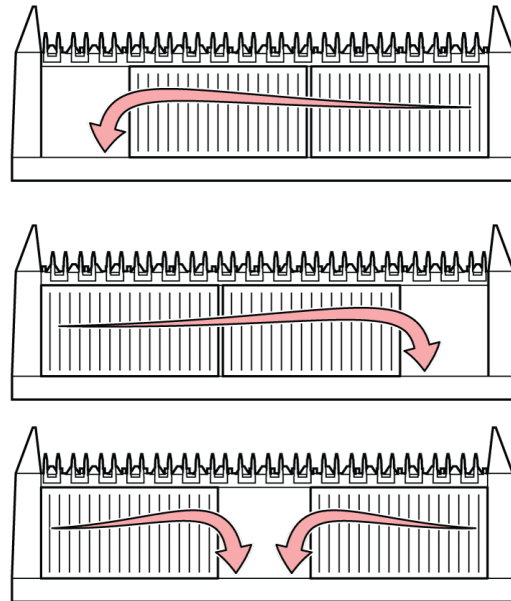

Fig. 144 - Deck Shift System Crop Flow

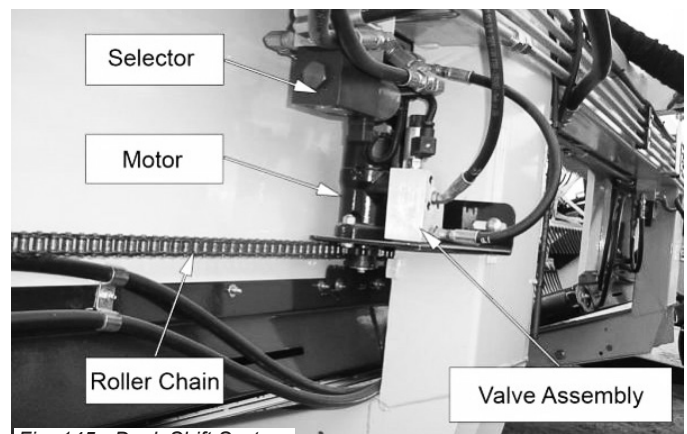

Fig. 145 - Deck Shift System

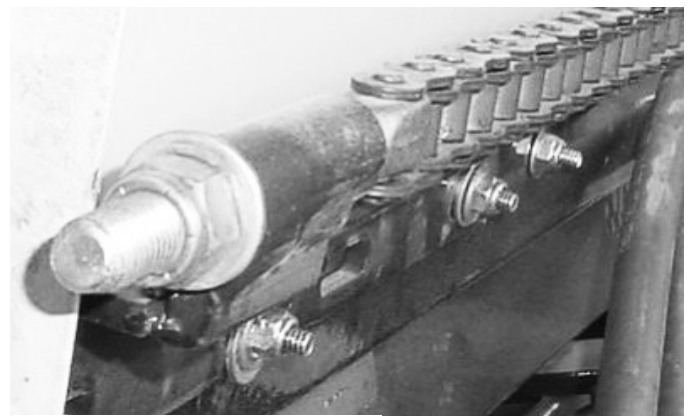

Fig. 146 - Roller Chain Tensioner

12.6 - Increasing Center Swath Opening

(Applies to 2016 & newer “Double Swath” tables with center draper drive motors)

The Honey Bee Swather has a provision for enlarging the center swath opening on a “Double Swath” table. For high volume crops, it may be necessary to increase the center opening in order to produce a good swath.

To enlarge the center opening, one or both decks may be shortened by removing the 14” wide deck extension near the center opening of the table.



This procedure involves cutting a section from the draper material. If you anticipate changing the opening back to the original size, you will need either a section of draper material and an extra connector bar kit for each draper you shorten, or a second set of drapers to be used with the narrower opening.

Note 1: The section you cut out will be too short for this purpose.

Note 2: newer versions (MY 2024) will include two-piece draper so no need to cut anything, just remove the short one.



Before servicing, engage park brake, shut off engine, and wait for all moving parts to stop. Ensure the swather is safely raised, with safety locks or blocks in place as needed.



The “Double Swath” option must be disabled while operating with the extensions removed. Disconnect the electrical connectors for both LH & RH decks to prevent accidental activation of the decks. Failure to do so may result in severe damage.



It is recommended to work on one draper deck at a time.
Keep all removed hardware and parts for re-assembly.

1. Raise the swather table and engage the Windrower's table lift lock mechanism (if this is too high for comfortable access, the table can be set on blocks or lowered to the ground)
2. Raise the reel and engage the locks on the lift cylinders to prevent the reel from falling.

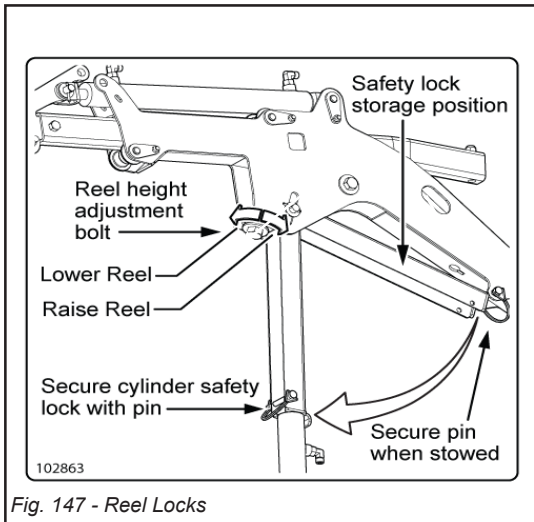
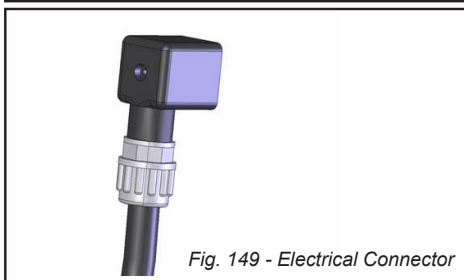
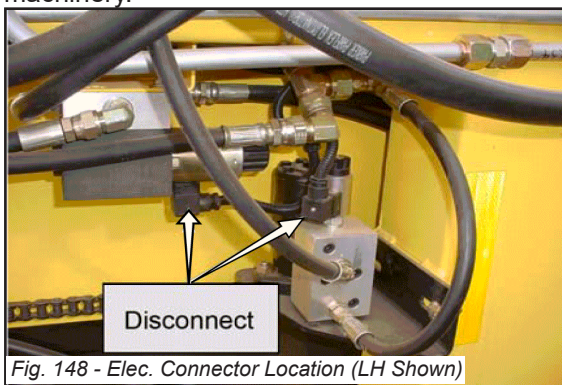
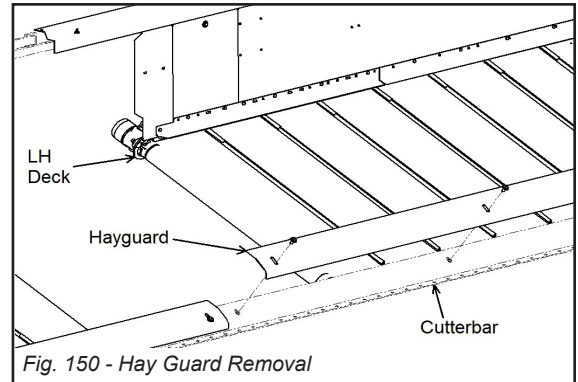

Fig. 147 - Reel Locks

3. Set the swath opening to the center delivery position, and run the drapers to get the connector bars on the top side. For both LH and RH decks, disconnect the deck shift electrical connectors on the control valves located at the struts. Cover the connectors to keep them clean, and secure them out of the way of moving machinery.



4. Remove the retaining hardware and hay guard sections from the cutter bar for the left-hand half of the table.



5. Remove the joiner bolt and washer from the end of the center tube shield. Loosen, **but do not remove**, the two retainer nuts on the tube shield. Once the tube shield is loose, remove it from the upper tube.

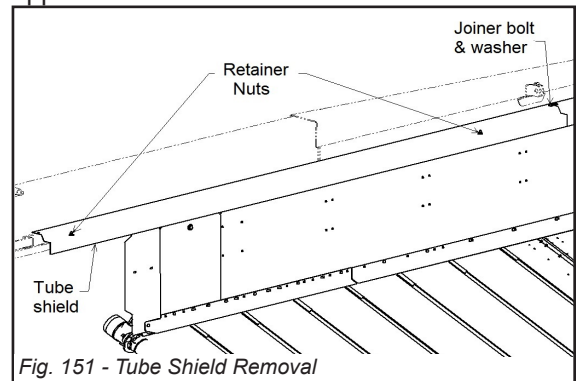

6. Remove the retaining hardware and back panel extension. Mark the motor hoses. Disconnect the hoses from the motor fittings, and cap/plug all open connections.

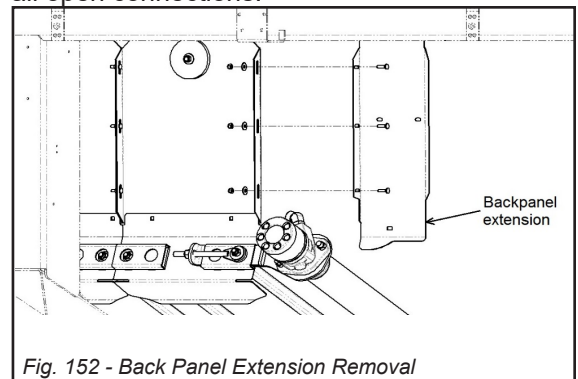

7. Release tension on the deck shift chain on the rear side of the deck by loosening the chain tension nut on the eyebolt.

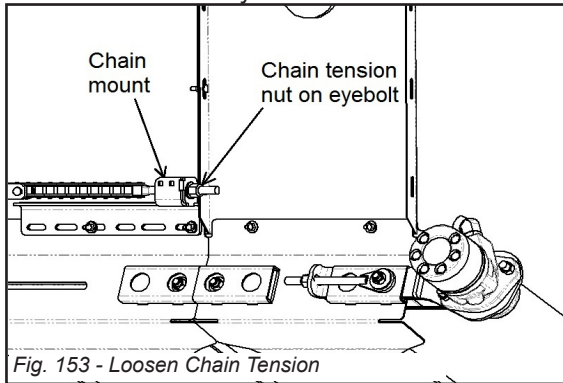

8. Remove the retaining hardware and first section of rear hay guard from the deck. The chain mount (with chain attached) on the rear side can hang down for now.

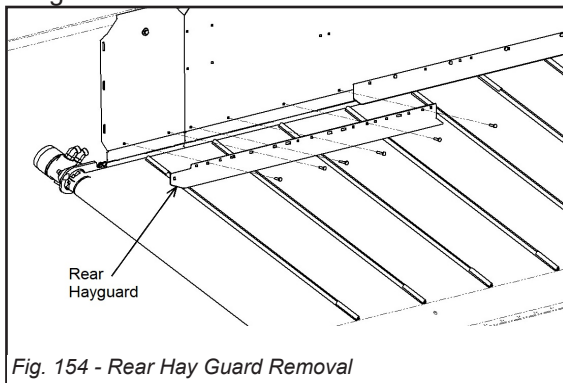

9. Release tension on the draper belt using the quick-release lever at the idler roller end of the deck.

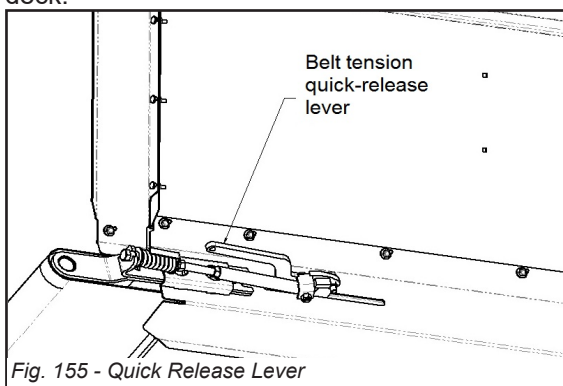

10. Turn the draper by hand to position the connector bar near the center opening. Open the draper joint at the connector bar and roll the draper back on top far enough to give room to work around the drive roller. If needed, you can also pull the lower section of the draper back to provide extra room.

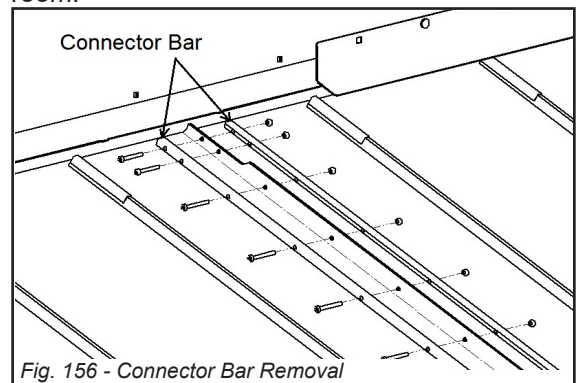

11. Remove the retaining hardware at the front and rear ends of the deck, then remove the drive roller (with motor and mounts) as a unit.

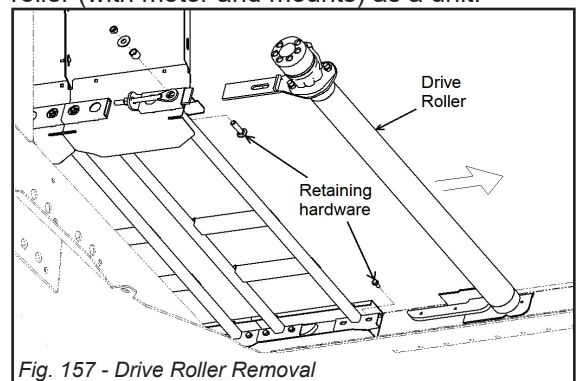

12. Remove the formed plate with eyebolt out of the channel of the 14 inch deck. **Do not** remove the nut or adjust the nut's position on the eyebolt.

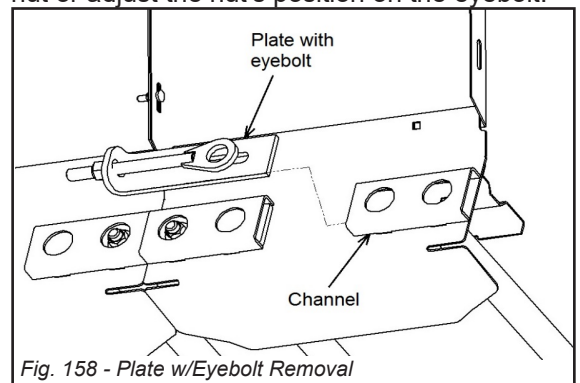

- Remove the retaining hardware and black disc from the 14 inch back panel. Remove the retaining hardware and 14 inch back panel from the table.

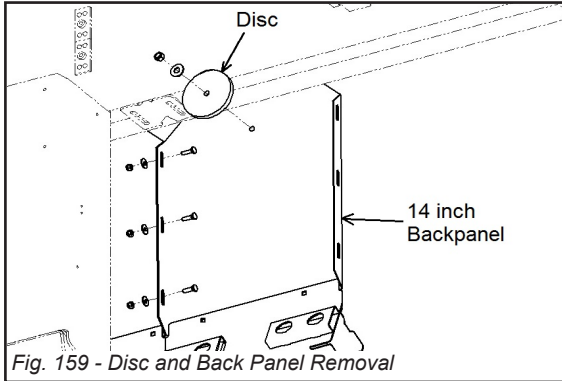

- Remove the retaining hardware and 14 inch deck (with connectors) as a unit from the table.

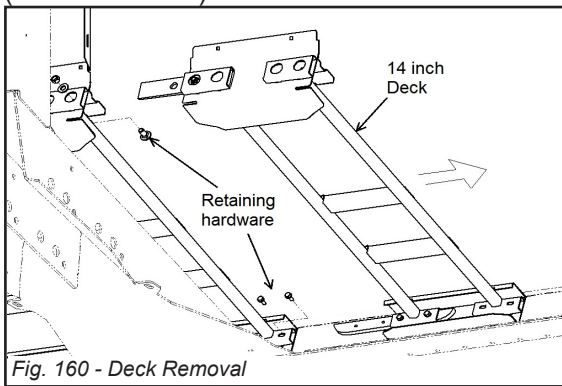

- Re-install the formed plate with eyebolt into the channel of the main deck.

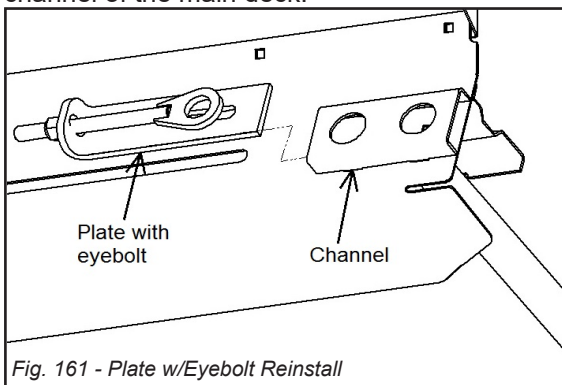

- Re-install the drive roller (with motor and mounts) as a unit into the main deck, and secure with the retaining hardware.

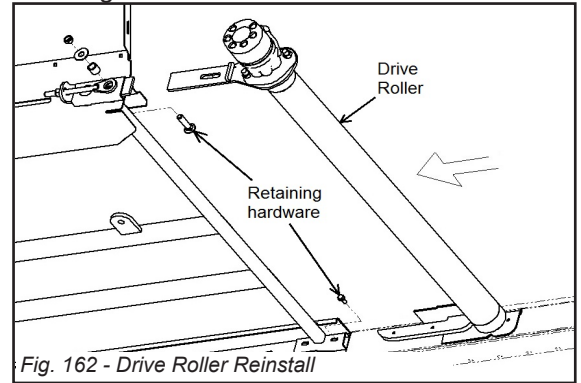

Before tightening the retaining hardware, make sure that the end of the formed plate is butted-up against the stop on the mount, and that the nut is against the face of the formed plate. **Do not** adjust the nut's position.

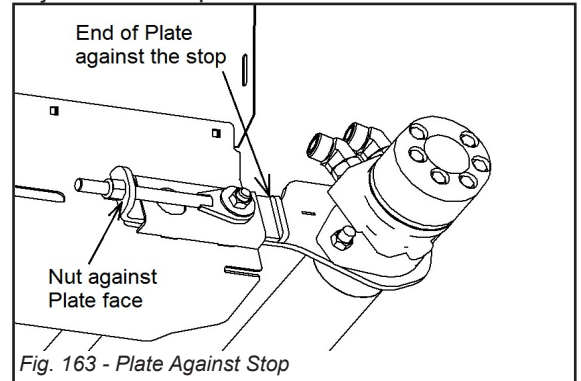

17. Draper shortening **for one piece draper only.**

- Stretch the draper back into place and carefully measure to determine the amount of material to be removed.
- The draper should be cut between two slats to provide ample material for the new join. Place a board directly under the line you have marked, to support the section you will be cutting. With a utility knife and a straight edge cut the draper along the marks. This cut must be accurate, and square, to assure that the draper will track properly.
- To mark the location for holes, measure 1" in from each edge to be joined, and mark a line parallel to the cut edges.
- On each of these lines, measure 1-1/8" from the front edge of the draper, and make a mark for the first hole.
- Drill 3/16" holes through each mark.
- Place the backs of the draper together, lining up these drilled holes.
- Place a connector bar on each side, line up the holes, and secure with a machine screw and nut.
- Match up the edges of the draper and drill a hole at the opposite end on the 1" line, using the connector bar as a template. Insert a screw and secure in place. Drill the remaining holes through the holes in the connector bar, insert screws and secure.
- Adjust draper tension. Trim all joins to 1/2" above connector bar.

PRO TIP: Retain the section of draper material you have removed as possible patch material for future repairs

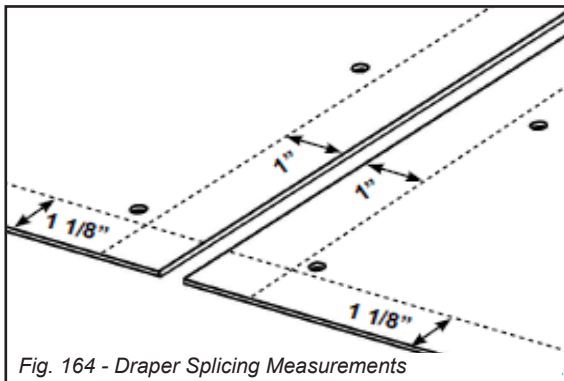

Fig. 164 - Draper Splicing Measurements

18. Shorten the end of the rear hay guard (removed in Step 8) by 14 inches, using an appropriate cut-off tool. Deburr all cut edges and touch-up with spray paint as required.

Keep the 14 inch cut-off piece for re-use if ever re-installing the 14 inch decks in the future (or purchase a new original length part).

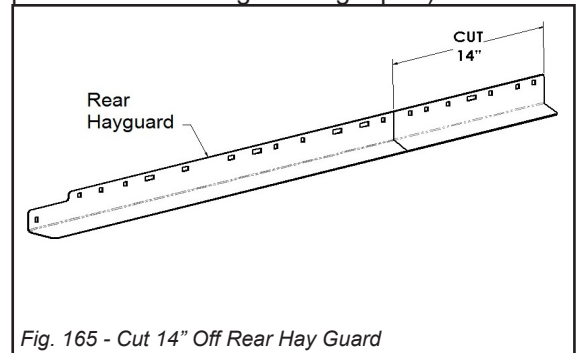

Fig. 165 - Cut 14" Off Rear Hay Guard

19. Using the retaining hardware, re-install the shortened rear hay guard at the end of the existing middle section of rear hay guard. Re-install the chain mount on the rear side of the deck. Do not re-install any hose clamps.

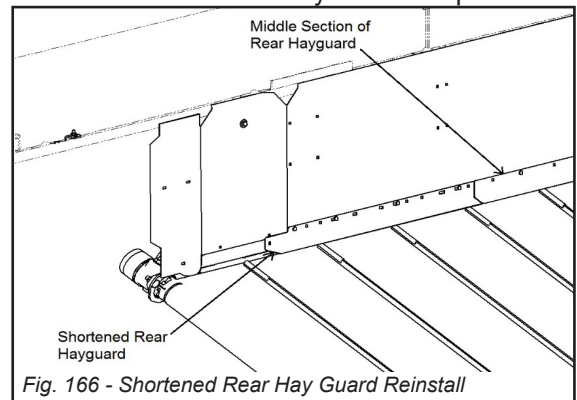

Fig. 166 - Shortened Rear Hay Guard Reinstall

20. If you decide to remove the chain and shifting motor, you will need to order deck braces (Fig. 167) to secure the decks. If the chain and motor remain engaged, braces are not required.

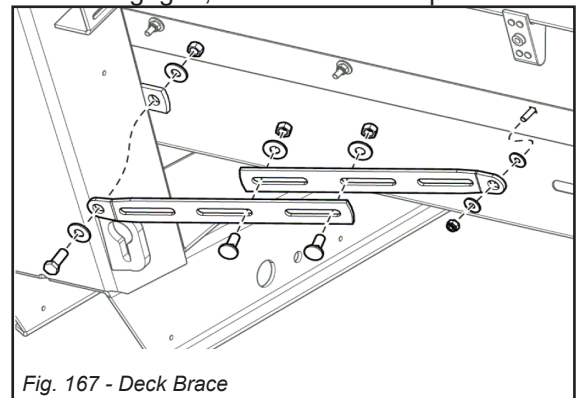

Fig. 167 - Deck Brace

21. Loosen any remaining hose clamps, pull the hoses back enough to match-up to the motor fittings, and re-connect the hoses to the motor fittings.

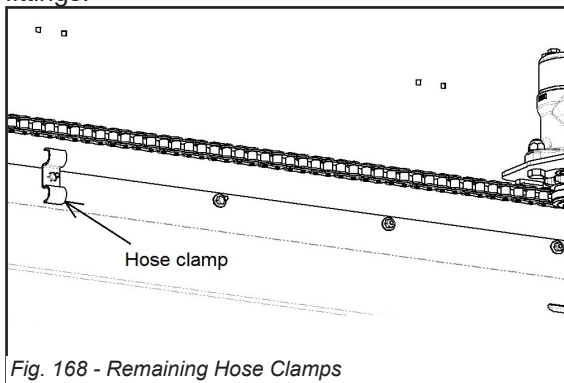

Fig. 168 - Remaining Hose Clamps

22. Re-install the back panel extension and secure with the retaining hardware.

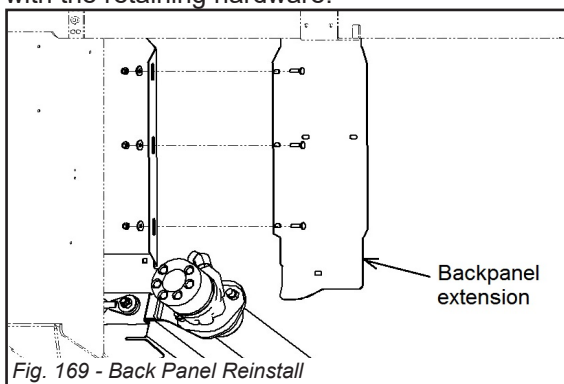

Fig. 169 - Back Panel Reinstall

- The draper motor hoses will have excess length. Secure them to the frame and away from the swather opening
- Adjust canvas tension and tracking as explained on page 61 & page 62
- Repeat these steps for the RH deck.

12.7 - Hay Guard / Short Crop Guard

Lay out Hay Guard starting at the end of the cutter bar. Install the longest section at the ends. The hay guards butt together end to end.

The hay guard should fit tight against the rise of the cutter bar leaving approximately $\frac{1}{4}$ " clearance between the ribs of the draper and the underside of the hay guard.

Secure the first hay guard in place using the threaded inserts, lock washers, flat washers and $\frac{3}{8}$ " x 1" button-head bolts as shown to the right. Install the next section of hay guard, butting it up to the first section. Continue until all sections of hay guard are installed.

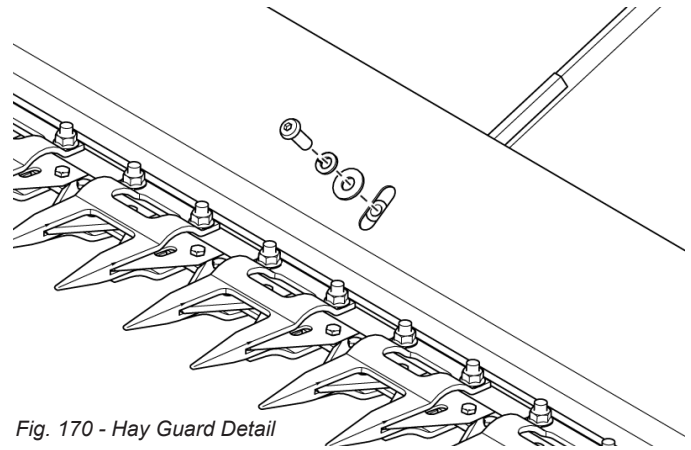

Fig. 170 - Hay Guard Detail

13 - Lubrication & Maintenance



Use good quality, general purpose grease, unless otherwise noted.

Component	Lubricant	Frequency/Notes
Knife Drives	Grease	Five(5) shots every 50 hours(fitting on side of knife drive)
Knife Head Bearing	Grease	One(1) shot every 50 hours(fitting above knife head)
Knife	Diesel	Soak with diesel or clean with a pressure washer
Reel Bearings	Grease	10 hours
Gauge Wheels – King Pin	Grease	10 hours
Wheel Bearings	Grease	Disassemble and re-pack yearly.
Hydraulic Return Line Filter	n/a	Change after first 50 hours of operation and seasonally thereafter. (Filter: HB - 27281/Donaldson – P164375) Refer to page 94 for a list of compatible filters.

The following maintenance decals and lubrication locations have been placed on your machine in the areas indicated. Please take this manual, walk around your machine and familiarize yourself with the lubrication locations and content of these decals. Review this information, with your machine operators. Please keep decals legible.

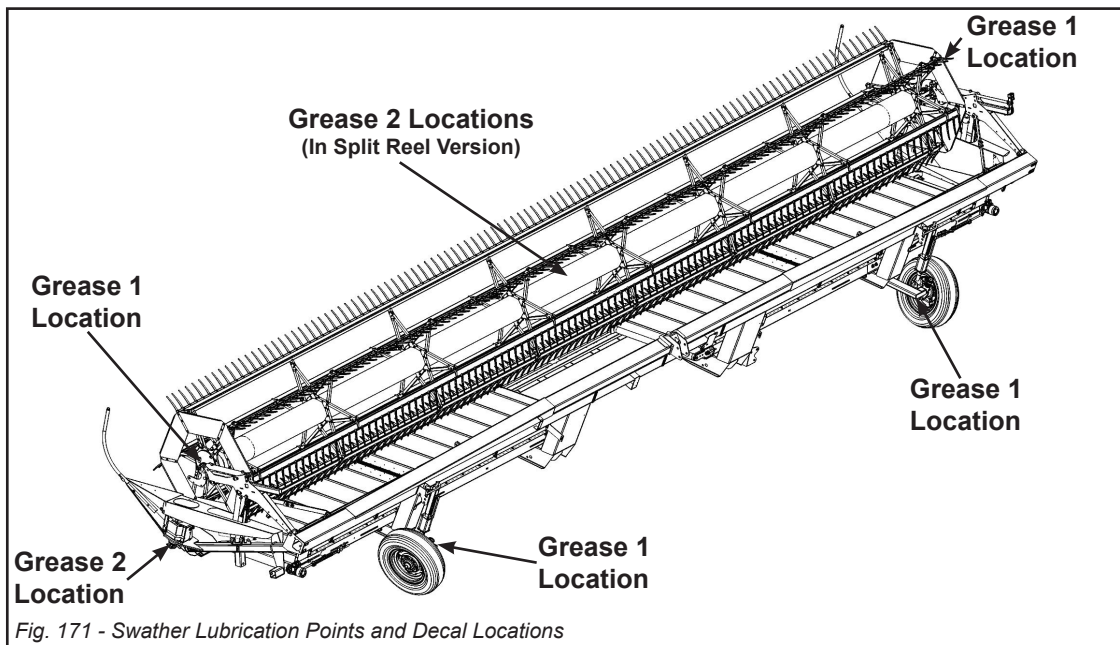

Fig. 171 - Swather Lubrication Points and Decal Locations

14 - Troubleshooting

Problem	Possible Cause	Solution
Reel		
Reel won't hold height.	Leaking hose or fitting.	Repair or replace.
	Valve in windrower leaking.	See windrower Manual.
Reel won't hold level.	Leaking hose or fitting.	Repair or replace.
	Air in system.	Bleed slave cylinder.
	Faulty cylinder.	Replace.
Reel raises or lowers erratically.	Reel cylinders binding.	Replace cylinder.
	Arms bent or binding.	Replace.
	Low hydraulic oil.	See windrower Manual.
Reel won't raise.	Hydraulic couplers don't match.	Install correct couplers.
	Valve is not open.	Open Valve.
	Faulty windrower hydraulics.	See windrower Manual.
	Reel not plumbed into tilt circuit.	Check plumbing schematic.
Damage to center of reel.	Reel set too low.	Adjust height.
	Reel tube bent.	Replace.
Reel hitting at end.	Reel not centered.	Adjust centering.
Reel will not turn or turns erratically.	Flow control set too low.	Advance setting.
	Draper flow set too high.	Reduce draper speed.
	Faulty relief valve.	Clean or replace.
	Seized bearing(s).	Replace bearing(s).
	Faulty drive motor.	Replace motor.
	Reel Tied Down.	Release Reel.
Reel Speed cannot be adjusted.	Poor electrical connection.	Check connections and cable.
	Defective reel speed motor.	Replace motor.
	Circuit breaker open or burnt out.	Replace.
Knife		
Knife won't run.	Low hydraulic oil.	Add oil. Determine cause of oil loss.
	Cutter Bar jammed.	Check for damaged guards or sections.
	Faulty drive motor.	Repair or replace motor.
	Faulty knife drive.	Repair or replace.
	Faulty hydraulic pump.	Repair or replace.
	Knife gummed	Clean cutter bar.

Problem	Possible Cause	Solution
Knife (continued)		
Knife Stalls Easy	Type of material being cut.	Reduce ground speed
	Low pressure at knife motor.	Check system pressure
	Bent guards or cutter bar.	Repair or replace
	Faulty knife drive.	Check for loose crank shaft
	Seized knife head bearing.	Replace
	Knife head out of alignment.	Adjust knife head bearing
Unloaded system pressure too high	Faulty draper motor.	Repair or replace
	Relief valve set too low (Should be set to 3000 psi).	Adjust
	Relief valve stuck open.	Remove and clean or replace cartridge
	Wrong type of hydraulic oil.	Change windrower hydraulic oil
	Flow control set low.	Set control higher
	Low oil level.	Add oil, locate cause and repair
	Low oil volume.	Reset volume, 19.5 gpm required
	Wrong motor size.	Check with manufacturer
	Worn pump or motor.	Repair or replace
Excessive vibration	Knife speed is too high.	Reduce knife speed
	Loose bearings in drive.	Replace bearings
	Loose knife head bolts.	Tighten knife head bolts
	Damaged sickles or guards.	Replace
Excessive noise	Guard bent or out of alignment	Straighten or replace
	Knife drive bearing faulty	Replace
	Knife drive loose	Tighten bolts and check for damage to housing
	Knife head out of adjustment	Adjust Knife Head bearing
Knife leaves strip of crop standing	Excessive ground speed	Slow down
	Bent or broken guard	Straighten or replace
	Broken knife section	Replace
	Plugged guard	Clean
Connector Bar breaks	Damaged sections or guards	Repair or replace
	Knife gummed up	Soak with diesel fuel, or wash with pressure washer
	Section bolts not tight	Tighten or replace
	Section or Knife Back installed on wrong side	Remove sections, turn Knife over and replace sections

Problem	Possible Cause	Solution
---------	----------------	----------

Knife (continued)

Knife Head breaks	Section bolts not tight.	Tighten and/or replace bolts.
	Knife gummed up.	Soak with diesel fuel, or wash with pressure washer.
	Damaged sections or guards.	Repair and/or replace.
	Sickle sections dull.	Replace sections.
	Tough crop.	Reduce ground speed.
	Knife drive running too fast.	Check speed with photo tach.

Draper

Draper not tracking straight	Drive or idler roller out of alignment.	Adjust draper tracking.
	Draper splice not cut straight.	Re-punch connector bar holes in draper.
	Material building up on rollers.	Clean rollers.
Draper slipping	Draper too loose.	Adjust draper tension.
	Draper is snagging.	Check alignment. Look for obstructions.
Draper not turning	Draper is snagged or caught.	Check for interference.
	Flow control is shut off.	Adjust flow control.
	Oil flow is being by-passed.	Check relief valve setting.
		Remove and clean relief cartridge.
Windrower RPM too low.	Increase windrower RPM.	
Draper oil pressure is excessive	Material build up on rollers.	Clean rollers.
	Faulty bearing in roller.	Replace bearing.
	Faulty draper motor.	Check motor temperature, check for oil leaking from shaft seal.
		Replace motor.

Decks

Decks creep sideways	Restrainer bars not installed or have fallen off.	Install or replace bars.
Decks lift out of position	Deck is not locked under rear edge of cutter bar.	Place deck in proper position.
	Hold down clips on back panels are loose or are not installed.	Tighten or replace.
Decks will not shift	Poor electrical connections.	Trace and repair.
	Electrical cable not plugged into windrower or control box.	Check connections.
	Decks or back panels jammed or binding.	Check decks and clean out debris.

Problem	Possible Cause	Solution
---------	----------------	----------

Decks (continued)

Heads shattering or breaking off.	Reel speed too fast.	Reduce reel speed.
	Ground speed too high.	Reduce ground speed.
	Crop over-ripe.	Cut earlier in morning or late at night when humidity is higher.
Cut grain falling off cutter bar.	Reel set too high.	Lower reel.
	Table set too high.	Lower table.
	Reel too slow for ground speed.	Increase reel speed.
Does not pick up lodged crop.	Table too high.	Lower table.
	Reel too high.	Lower reel.
	Reel too far back.	Move reel forward.
	Ground speed too fast for reel speed.	Reduce ground speed or increase reel speed.

Hydraulic Oil

Temperature is too high.	Excessive oil going over reliefs.	Check reliefs on flow controls.
	Faulty pump or motors.	Repair or replace.
	Draper too tight or not tracking.	Adjust draper alignment.
	Oil too light.	Refill with correct grade.

Leveling

Swather not level.	Float pressure too low.	Adjust float pressure for the side that is too low.
--------------------	-------------------------	---

Table Angle

Draper running too flat or too steep.	Tilt cylinder out of adjustment.	Adjust.
---------------------------------------	----------------------------------	---------

Raising and lowering the Swather

Swather will not lift.	Windrower lift capacity.	Check system pressure
Swather table lifts and lowers too slowly.	Lift rate set too low	Adjust lift rate via windrower settings.

Problem	Possible Cause	Solution
Lift and Float Systems		
Platform Does Not Follow Ground Contour. NOTE: If float pressure is set too high platform will feel light and bouncy. If float pressure is too low, the platform will feel heavy and unresponsive. It should require less than 150 lbs to lift the end of the platform.	Platform float pressure too high, making platform feel light.	Check windrower operator's manual. Adjust float pressure.
	Field/Road switch in the Road Position.	Set switch to Field position.
	Faulty Relay.	Replace Relay.
	Accumulator pre-charge pressure too low.	See your windrower manual.
Platform Digs Into Ground and Pushes Hard.	Guards digging into ground.	Adjust guard angle, with hydraulic tilt cylinder.
	Platform float pressure too low, making platform feel too heavy.	Adjust float pressure.
	Accumulator pre-charge pressure too high.	See your windrower manual.
Platform Drops Too Fast or Does Not Lower Smoothly.	Platform float pressure too low, making platform too heavy.	Adjust platform float.
	Accumulator pre-charge pressure too high.	Adjust platform float.
		See your windrower manual.
Platform Will Not Lift or Lifts Too Slow.	Binding lift linkage.	Replace bent or worn parts.
	Platform float pressure too low, making platform too heavy.	Adjust platform Float.
	Worn lift pump.	See your windrower manual.
	Low Relief valve setting.	See your windrower manual.
	Faulty switch or relay.	Replace.
	Faulty solenoid or valve cartridge.	Replace.

15 - Lighting

The lighting system incorporates two circuits; the transport running lights for use when moving the swather via the transport hitch and the warning flashers which are used when operating the swather in the field.

15.1 - Transport Lights:

- The transport lights consist of two wiring harnesses and two (tail, signal, and stop) lights.
- The 52ft (15.84m) Harness extension with a male (Universal Trailer Connector, 4 Pole) leads to the towing equipment. It is the transporters' responsibility to ensure proper connection to towing equipment.
- The 9.8ft (3m) Harness wishbone with male (Universal Trailer Connector, 4 Pole) that connects to the female end of the 52 ft (15.84m) extension harness. The plugs on the other end connect directly to the pig tail of the lights.

15.2 - Warning Flashers:

- The warning flasher light wiring consists of a 12.5 ft (3.81m) pigtail harness that attaches from the windrower to the warning flasher harness. The adaptor plug (JD - 7 - way connector) is installed at factory with the reel speed wiring plug.
- The warning flasher harness is a total of 45 ft (13.73m) in length and connects the warning flasher lights to the windrower.

All swathers are equipped with clearance lights as well as signal and brake lights. Ensure that all lights are in good working order, and that you swing them out to their transport positions before transporting the header.

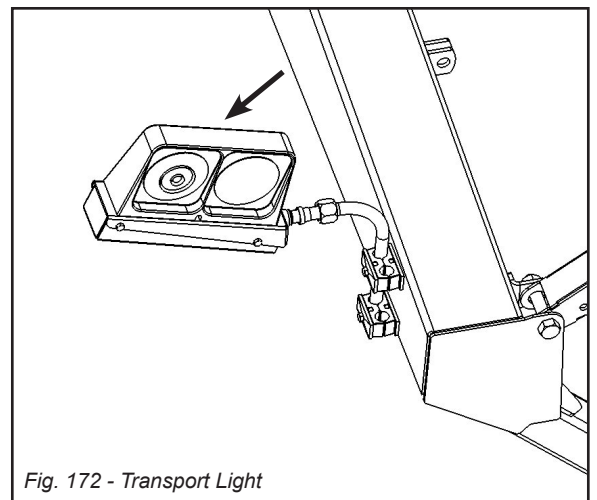

Fig. 172 - Transport Light

15.3 - Wiring

Amber - Warning Flasher

Red/Amber - Tail. Signal and Stop

Warning Flashers

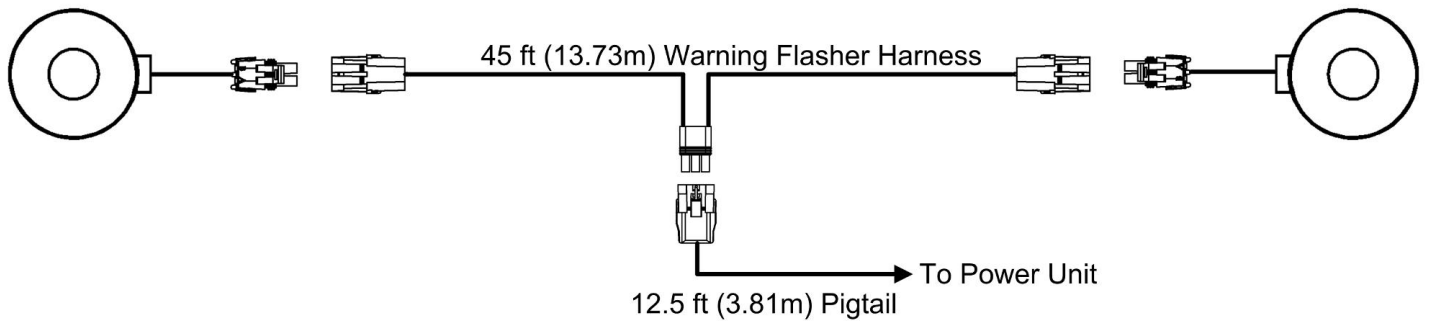

Transport Lights

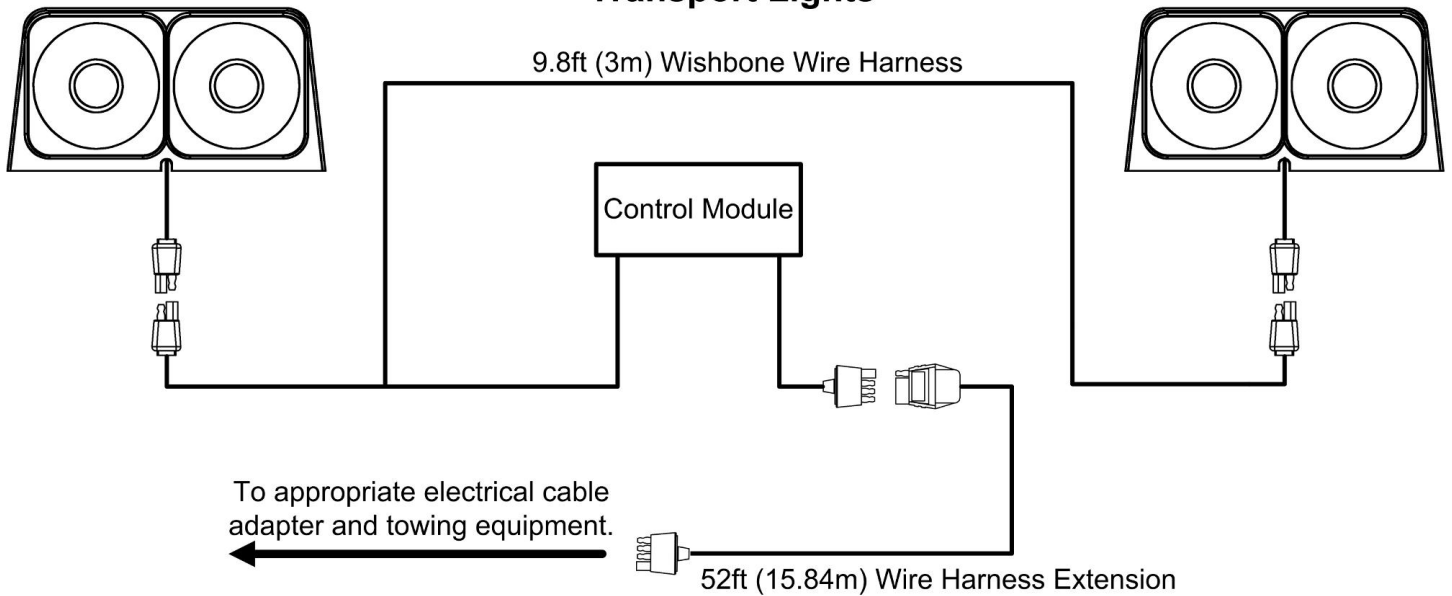

The lights operate on two circuits:

- Transport lights.
- Warning flashers.

15.4 - Transport Lights

Transport lights should be used at all times when the swather is towed on public roads. Connect to the tow vehicle using the proper plugs.

Wiring color code:

- White - Ground
- Brown - Tail Lamps
- Green - Right Hand Stop / Turn signal
- Yellow - Left Hand Stop / Turn signal

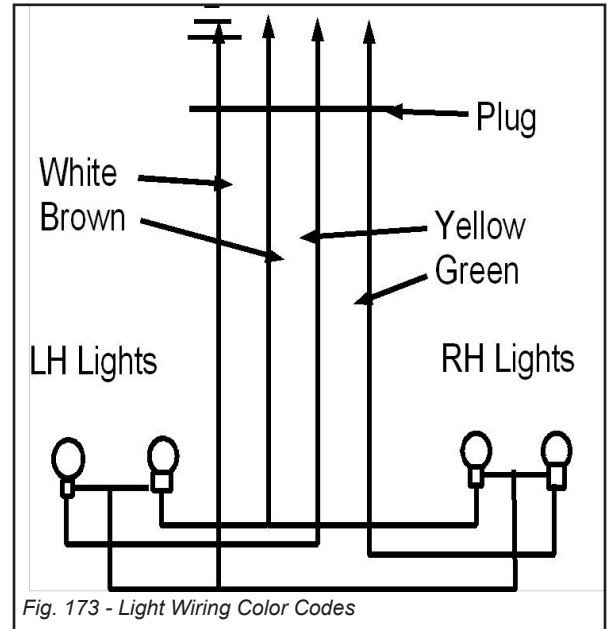

Fig. 173 - Light Wiring Color Codes

15.5 - Warning Flashers

When transporting the swather while it is mounted to the windrower, hazard warning lights must be connected and operating. The amber warning lamps must be visible from both the front and the rear.

Wiring Layout:

- White - Ground
- Green - Right Flasher
- Yellow - Left Flasher

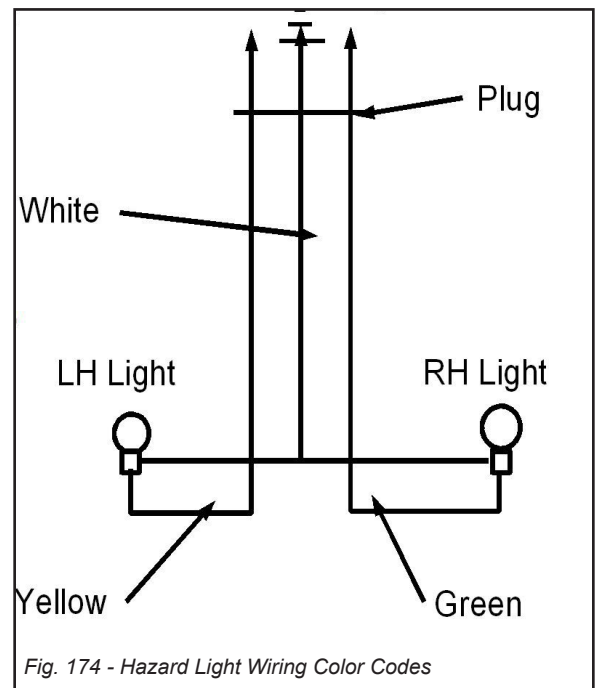

Fig. 174 - Hazard Light Wiring Color Codes

Be Seen. Be Safe!

16 - Appendix

16.1 - Hydraulic Fitting Naming Standards

There will be a number of different hydraulic fittings used in this manual. The naming standards can be a little confusing, however this section should clear up any questions you may have.

A standard 2 sided hydraulic fitting is named in the following format:

- ##XX-##XX

The information on each side of the hyphen represents its respective end of the fitting. The '#' is the size designation. The 'X' denotes the type of end on that side of the fitting, this information is divided into a prefix and a suffix. The prefix indicates either male or female, and the suffix indicates the type of connection.

A 'T' fitting will be named in the following format:

- ###XX-##XX-##XX

The center set of characters describes the middle port on the 'T' fitting.

The size designations denotes which fittings go together. For example, a 10FJ fitting will fit with a 10MJ fitting, but not a 12MJ.

Hydraulic Fitting Types		
Prefix	Suffix	Description
M or F	J	JIC 37° flared connectors
M or F	F	Face Seal
M or F	P	Pipe Fitting
M or F	B	O-Ring Boss
F only	X	Swivel (no image shown)
M or F	STC	Snap To Connect

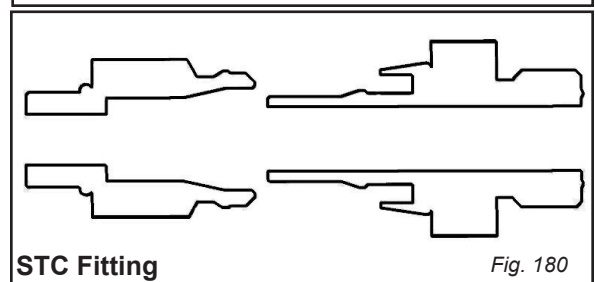
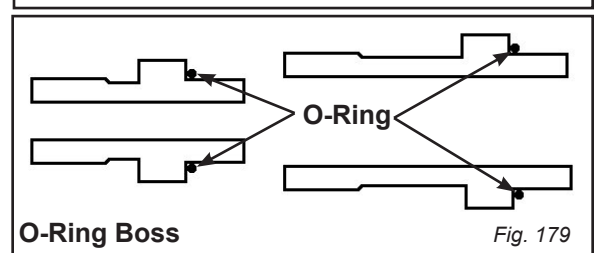
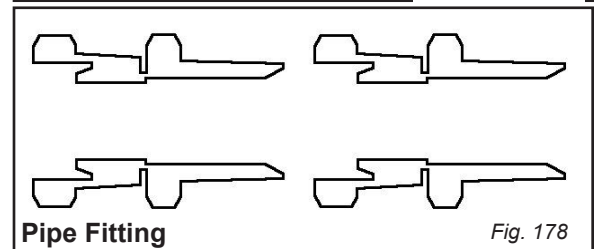
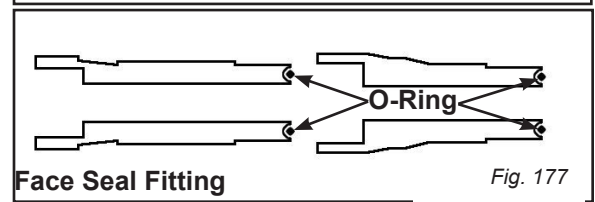
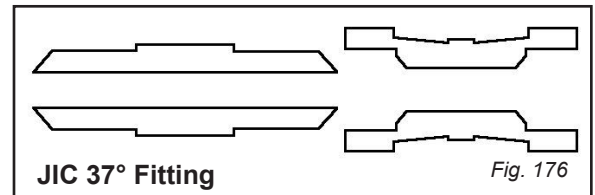
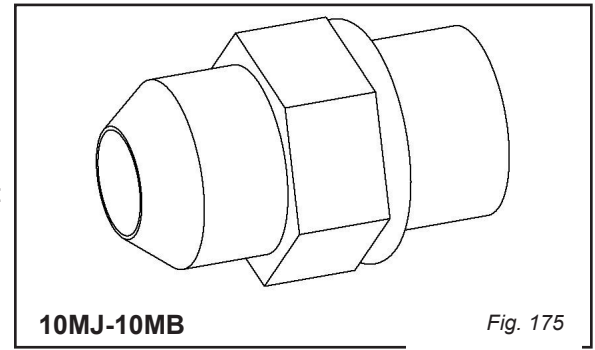

16.2 - Electrical Schematics & Charts

16.2.1 - Swather Table Electrical Schematic

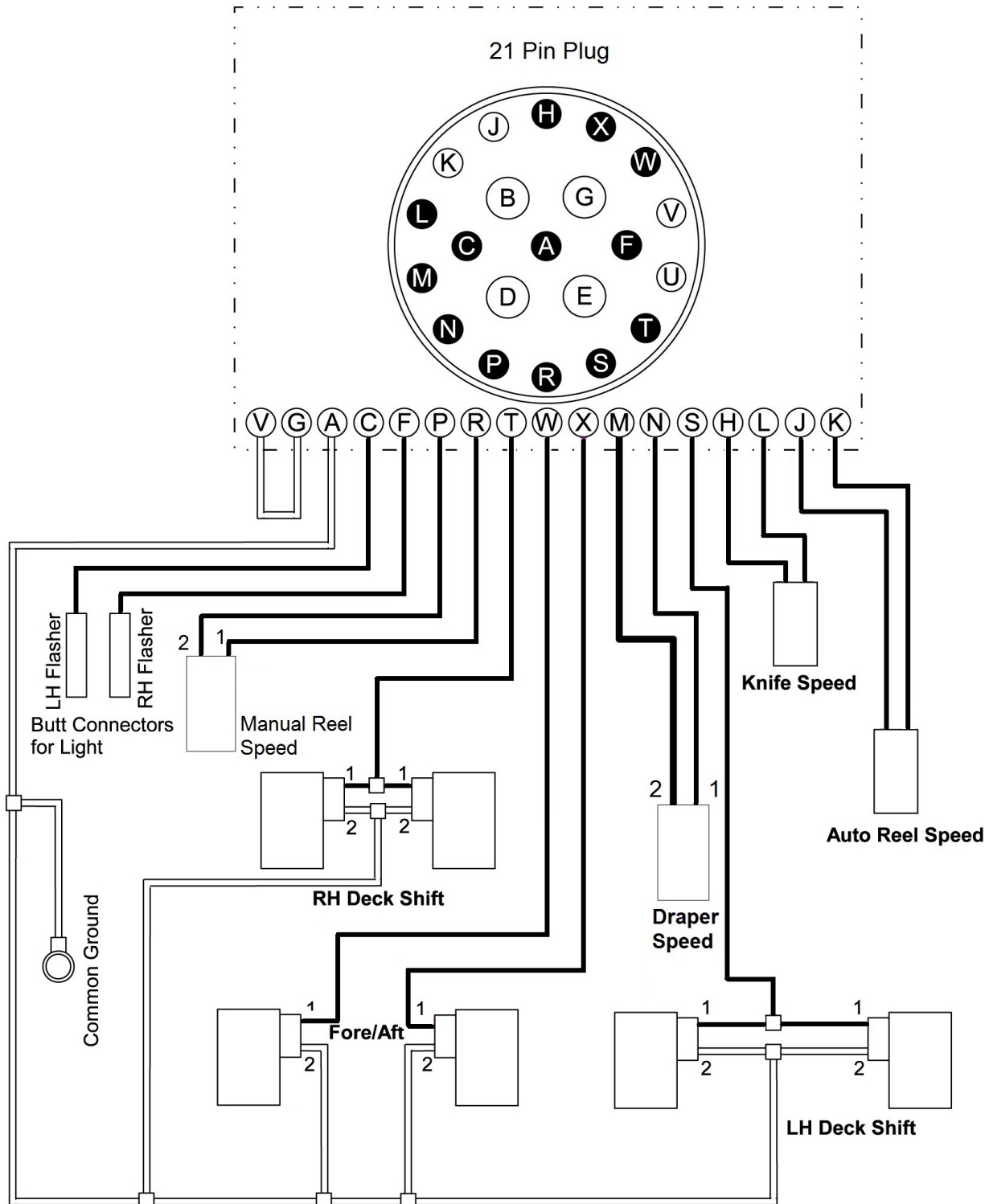

16.2.2 - Common 21 Pin Plug Features

Cavity	Circuit Reference
A	Power Ground
B	
C	LH header Flashing Light
D	
E	
F	RH header Flashing Light
G	Recog Jumper to V
H	Header Speed Sensor
I	
J	Auto Reel Speed (decrease)
K	Auto Reel Speed (increase)
L	Knife Speed
M	Draper Speed (decrease)
N	Draper Speed (increase)
O	
P	Manual Reel Speed (decrease)
R	Manual Reel Speed (increase)
S	LH Deck Shift*
T	RH Deck Shift*
U	
V	Recog Jumper to G
W	Fore/Aft (Aft)
X	Fore/Aft (Fore)

*Double swath header only

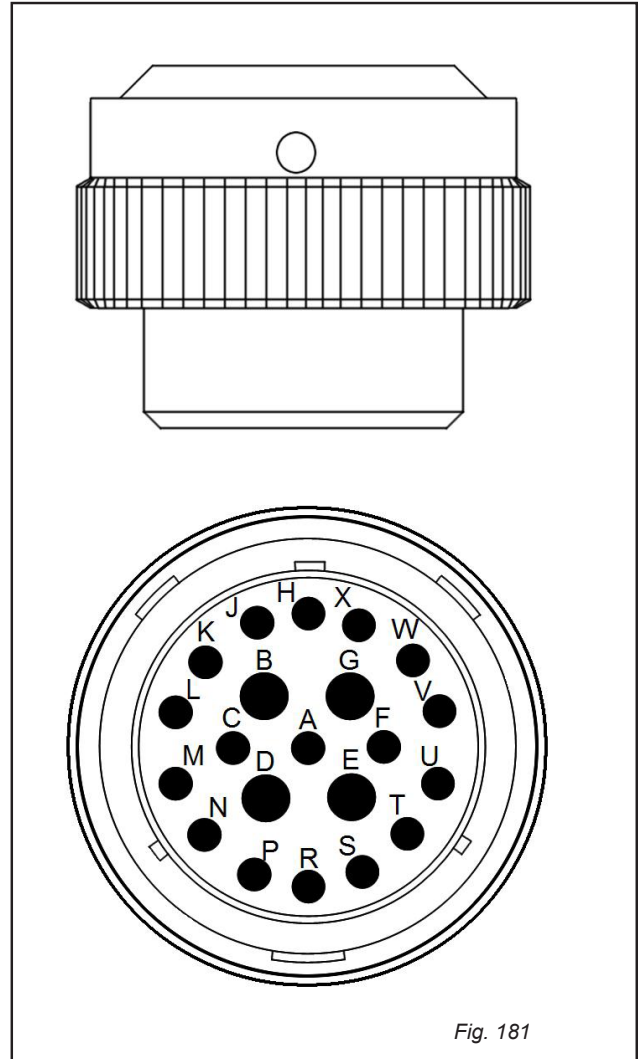
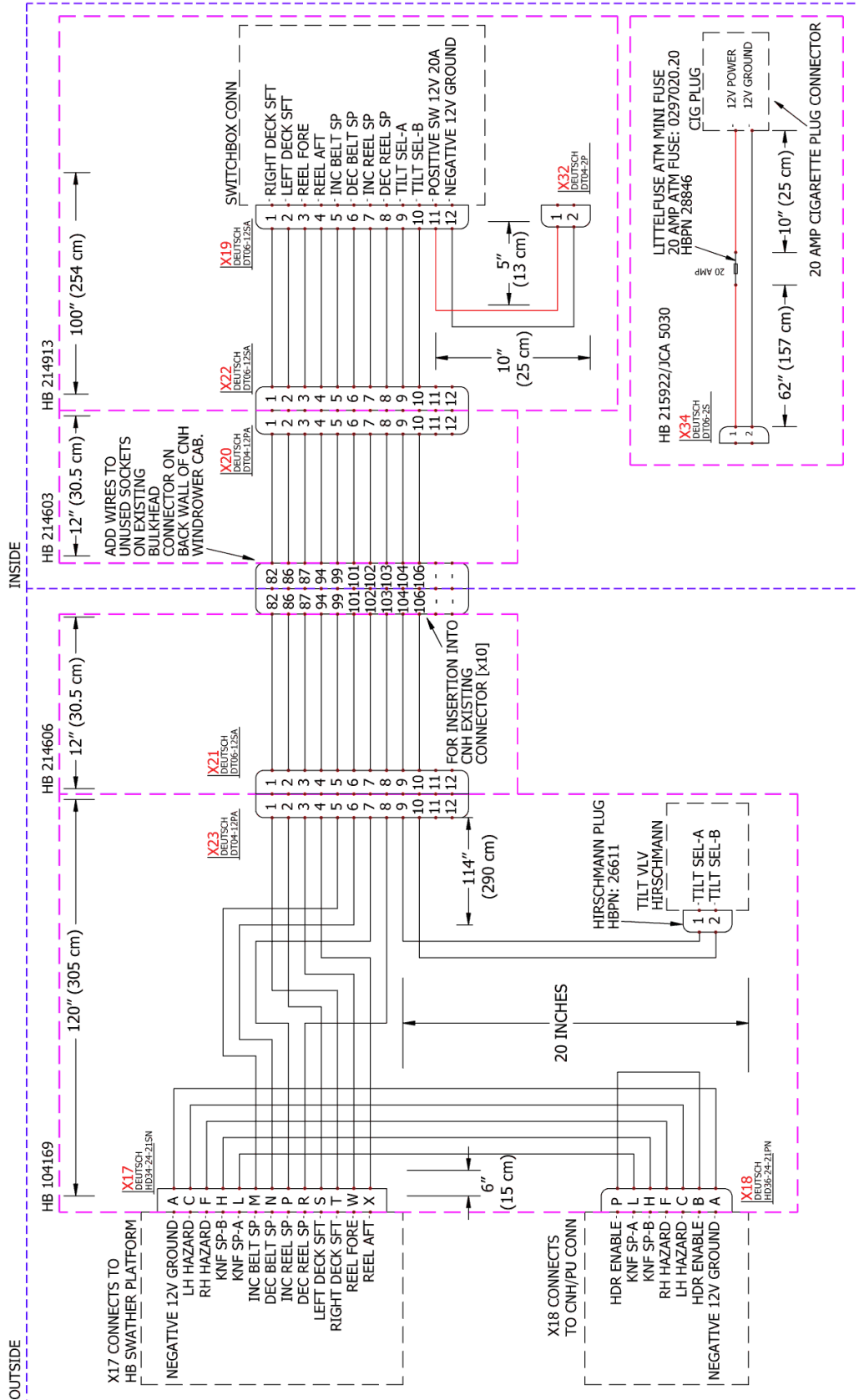

Fig. 181









Pins G, J, K, and V do not apply to Honey Bee swathers.

16.2.3 - Adapter Wiring Schematic

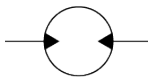
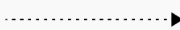
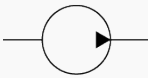

16.3 - Hydraulic System Schematics

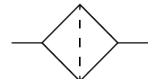
16.3.1 - Hydraulic System Schematic Symbols

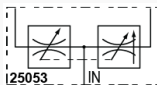
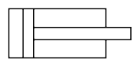
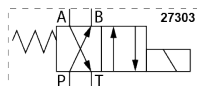
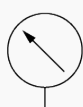
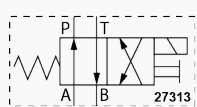
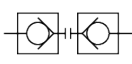
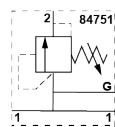
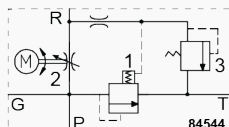
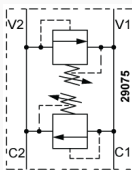
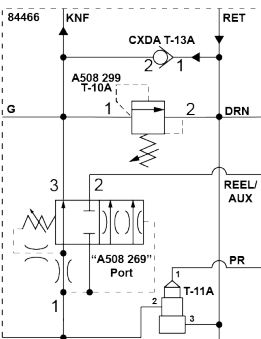
	Oil flow - bidirectional		Capped port
	Oil flow - unidirectional		Hydraulic motor - bidirectional
	Bypass flow - unidirectional		Hydraulic motor - unidirectional
	Motor rotation - bidirectional		Oil filter
	Motor rotation - unidirectional		Flow divider
	Hydraulic cylinder		Selector valve
	Pressure gauge		2 position deck shift valve
	Quick coupler		3 port relief valve
	Flow control with relief valve		Cross-over relief valve
	Upper tube hydraulic manifold block		

16.3.2 - Double Swath - Double Knife - Solid Reel - System Hydraulic Schematic

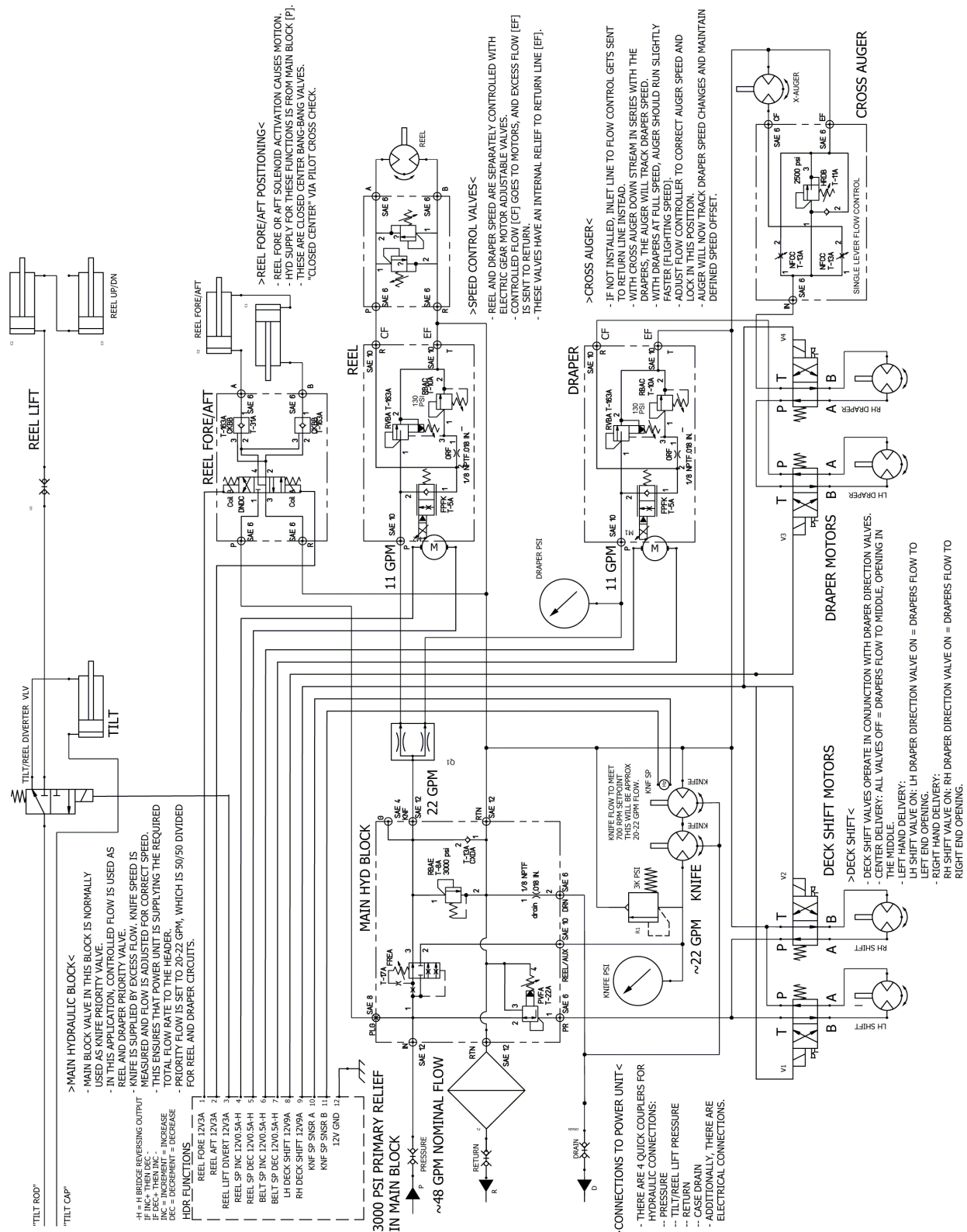

16.3.3 - Single Swath - Double Knife - Solid Reel - System Hydraulic Schematic

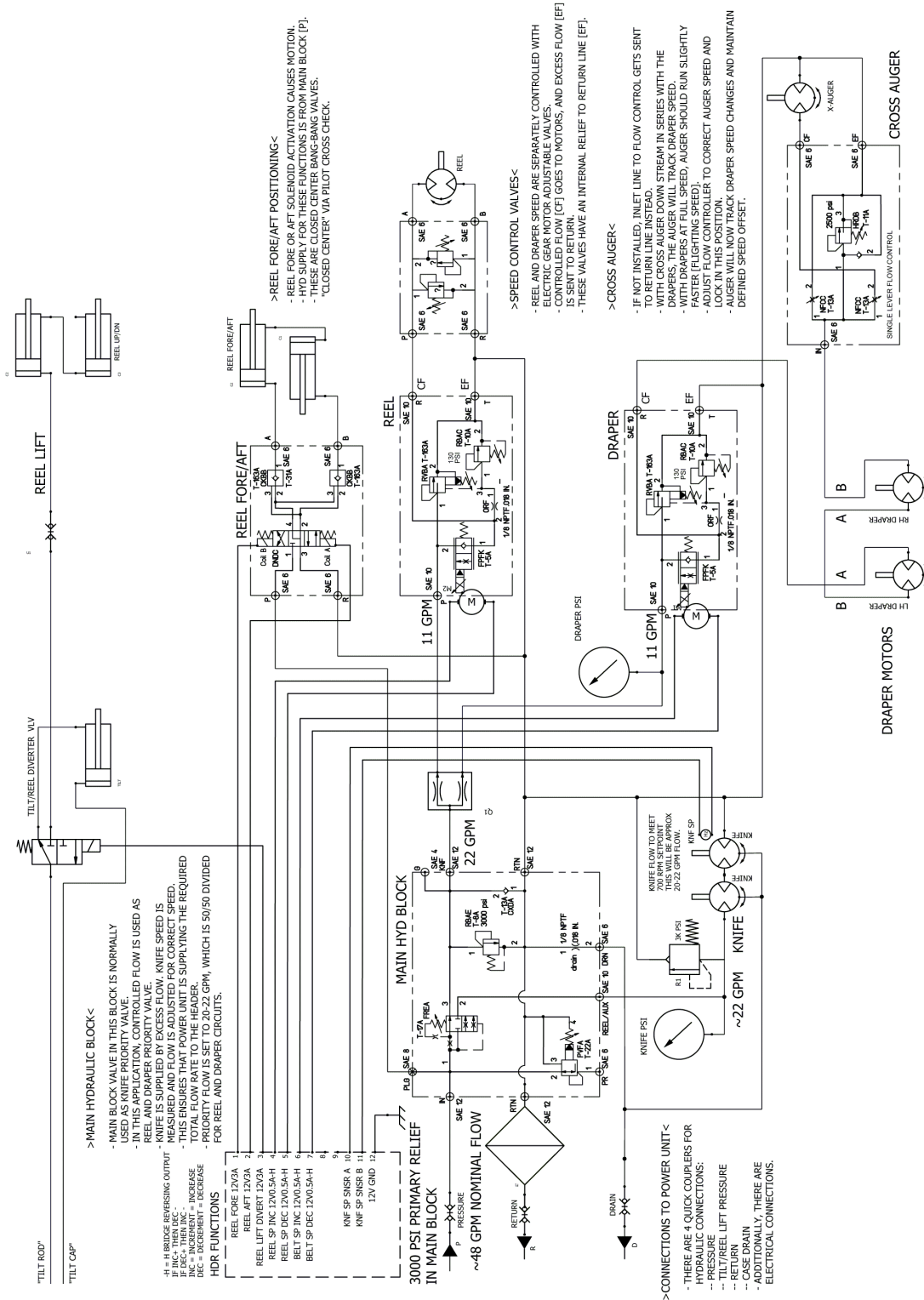

16.4 - Dimensions

Refer to the illustration below for the following dimensions:

Model (ft/m)	A (in/cm)	B (in/cm)	C (in/cm)
15ft (15/4.5)	100/254	80/203	100/254
25ft (25/7.6)	110/280	80/203	110/280
30ft (30/9.1) Single Swath	135/342	80/203	135/342
30ft (30/9.1) Double Swath with center delivery	149/378	56/142	149/378
36ft (36/11) Single Swath	174/441	80/203	174/441
36ft (36/11) Double Swath with center delivery	188/477	56/142	188/477

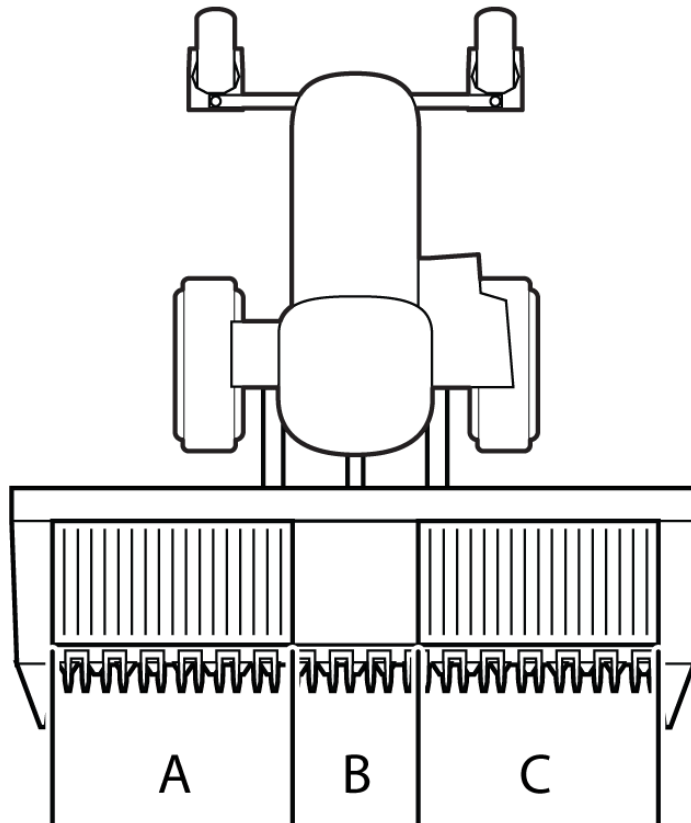

Fig. 182 - Single Swath Delivery

16.5 - Windrow Type

Several factors affect windrow formation: Ground speed, draper speed, type of crop, reel speed, table angle, and stubble height. This manual will give the operator some guidelines in how machine settings can affect windrow formation. It is the operator's responsibility to adjust the settings for the type of windrow desired.

16.5.1 - Windrow Formations

Herringbone: The ideal formation for weathering and ease of pick up. The crop needs to be standing straight or leaning uniformly in one direction.

Parallel: A good windrow that is easier to form.

Angled Parallel (75 Degree Diagonal): A good windrow but not as good as the parallel.

Fan Tail: Good weathering ability and easy to pick up, but not as good as the first three types.

Diagonal (45 Degrees): This swath is less desirable, because the heads are concentrated on one side of the swath. It is more difficult to pick up and is more easily affected by wind or rain.

Dovetail: Also less desirable, because heads are concentrated in the middle of the swath. More difficult to pick up and more easily affected by wind or rain.

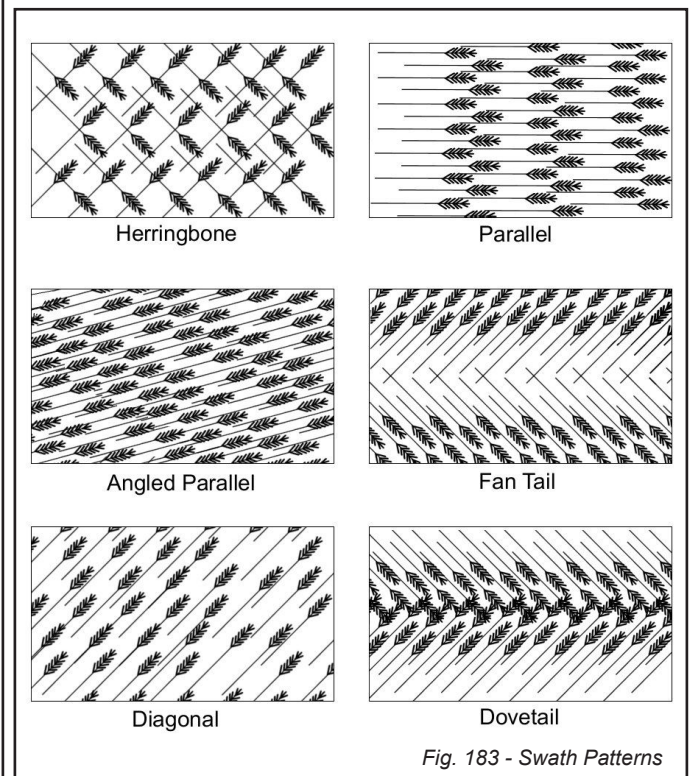

Fig. 183 - Swath Patterns

16.5.2 - Ground Speed

Use windrow quality as a guide to travel speed. Cut at lower speeds when terrain is rough and when crops are lodged or tangled. Excessive speed may be indicated by a ragged cut in the stubble.

16.5.3 - Stubble Height

For most crop types, best results are obtained when the table is adjusted for a stubble height of 6" to 8" or (150 to 200 mm). This height of stubble should have strength to support the windrow and to provide air flow underneath. Also, the windrow should be easier to pick up.

16.6 - Specifications/Features

16.6.1 - Weights

This weight includes the following options:

- Reel
- Flotation (caster) gauge wheel
- End strut gauge wheels
- Transport axle/hitch
- Double swath (the single swath will be 210 lb lighter)

Model	WSC15	WSC25	WSC30	WSC36
Width	15'	25'	30'	36'
Weight	3465 lbs 1572 kg	4950 lbs 2245 kg	5500 lbs 2495 kg	6346 lbs 2878 kg

Windrower required ballast weights (For MY23-MY25 6 Cyl)

Model	WSC15	WSC25	WSC30	WSC36
Width	15'	25'	30'	36'
Weight	550-725 lbs	1000-1100 lbs	1150-1184 lbs	1320 lbs
Notes	27-35 plates in rear weight box (No rear weight bracket kit needed)	Combination of rear weight kit and weight box plates needed	Combination of rear weight kit and weight box plates needed	Combination of rear weight kit and weight box plates needed. 20 plates in weight box (320lbs) and 6 suitcase weights (600lbs), plus rear bracket weight (100lbs) is currently the recommended setup

16.6.2 - Technical Specifications

- Knife Drive - SCH epicyclic 3 5/16" stroke, hydraulically driven, 1100-1400 strokes per minute. (2 strokes = 1 RPM)
- Cutting System - SCH Easy Cut, spring steel guards and bolted sections.
- V-Guided Draper - 42" Rubberized polyester, fiberglass reinforced, tie bar connectors.
- Draper Speed - adjustable in cab, 0-760 fpm.
- Reel Speed - adjustable in cab.
- Adjustable cutting angle.
- Standard single swath opening is approximately ~80".
- Standard double swath opening is approximately ~56".



Specifications are subject to change without notice or obligation.

16.6.3 - Options

- End Strut Gauge Wheels
- Cross Auger Kit (Not available for WSC21)
- Swath Delivery Kits - Hydraulic deck shift.
- Ziegler vertical shear mounting brackets.

16.6.4 - Included in Standard Swather

- Storage Axle and Hitch
- Remote Draper Speed Control + Reel Speed Control
- Hay Guard
- UHMW Poly Skid Plate
- Caster Gauge Wheels - WSC30, WSC36
- Tires/Wheels/Hubs/Spindles
- Fore/Aft Hydraulic Reel Adjustment

16.7 - Bolt Torque

The tables shown below give correct torque values for various bolts and cap screws. Tighten all bolts to the torques specified in chart unless otherwise noted. Check tightness of bolts periodically, using bolt torque chart as a guide. Always replace fasteners with the same strength rating and size.

Unified Torque Specifications				
Grade	SAE 5		SAE 8	
Size	Nm	Lb-ft	Nm	Lb-ft
1/4"	12	9	17	12
5/16"	25	19	36	27
3/8"	45	33	63	45
7/16"	72	53	100	75
1/2"	110	80	155	115
9/16"	155	115	220	165
5/8"	215	160	305	220
3/4"	390	290	540	400
7/8"	570	420	880	650
1"	915	675	1320	970

Metric Torque Specifications				
Grade	8.8		10.9	
Size	Nm	Lb-ft	Nm	Lb-ft
M6	11	8.5	17	12
M8	28	20	40	30
M10	55	40	80	60
M12	95	70	140	105
M14	150	110	225	165
M16	240	175	350	255
M18	330	250	475	350
M20	475	350	675	500
M22	650	475	925	675
M24	825	600	1150	850



Torque figures indicated above are valid for non-greased or non-oiled threads and heads unless otherwise specified. Therefore, do not grease or oil bolts or cap screws unless otherwise specified in this manual. When using locking elements increase torque values by 5%.

16.8 - Hydraulic Fitting Torque

Tightening Flare Type Tube Fittings

- Check flare and flare seat for defects that might cause leakage.
- Align tube with fitting before tightening.
- Lubricate connection and hand tighten swivel nut until snug.
- To prevent twisting the tube(s), use two wrenches. Place one wrench on the connector body and with the second tighten the swivel nut to the torque shown.

Hydraulic Torque Fitting Table					
Tube OD Size	Nut Size	Torque Value	Torque Value	Flats to tighten	Turns to tighten
Inches	Inches	Nm	lb-ft	-	-
3/16"	7/16"	8	6	1	1/6
1/4"	9/16"	12	9	1	1/6
5/16"	5/8"	16	12	1	1/6
3/8"	11/16"	24	18	1	1/6
1/2"	7/8"	46	34	1	1/6
5/8"	1"	62	46	1	1/6
3/4"	1-1/4"	102	75	3/4	1/8
7/8"	1-3/8"	122	90	3/4	1/8



The torque values shown are based on lubricated connections as will be found in reassembly.

16.9 - Tightening O-ring Fittings

- Inspect O-ring and seat for dirt or obvious defects.
- On angle fittings, back the lock nut off until washer bottoms out at top of groove.
- Hand tighten fitting until back-up washer or washer face (if straight fitting) bottoms on face and O-ring is seated.
- Position angle fittings by unscrewing no more than one turn.
- Tighten straight fittings to torque shown.
- Tighten angle fittings to torque shown while holding body of fitting with a wrench.

O-ring Fitting Values					
OD Thread	Nut Size	Torque Value		Flats to Tighten	Turns to Tighten
Inches	Inches	Nm	Lb-ft	-	-
3/8	1/2	8	6	2	1/3
7/16	9/16	12	9	2	1/3
1/2	5/8	16	12	2	1/3
9/16	11/16	24	18	2	1/3
3/4	7/8	46	34	2	1/3
7/8	1/2	62	146	1-1/2	1/4
1-1/16	1-1/4	102	75	1-1/2	1/6
1-3/16	1-3/8	122	90	1-1/2	1/6
1-5/16	1-1/2	142	105	3/4	1/8
1-5/8	1-7/8	190	140	3/4	1/8
1-7/8	2-1/8	217	160	1/2	1/12



The torque values shown are based on lubricated connections as will be found in reassembly.

16.10 - Compatible Replacement Hydraulic Filters

When replacing the OEM hydraulic filter (Donaldson P164375) on the swather, ensure you select a compatible filter.

Acceptable replacement filters must meet the following specifications:

- Working pressure to 500 psi
- Rated static burst to 1000 psi
- MIN filter collapse rating is 150 psi
- Flow range to min 35 gpm
- Beta rating $\beta_{<9(c)}=1000$
- Filter rate 9 μm
- Thread size is 1 3/8-12UNF-2B
- Bypass rating 25 psi



Honey Bee

Harvest Faster

2024 WSC Swather Op Manual

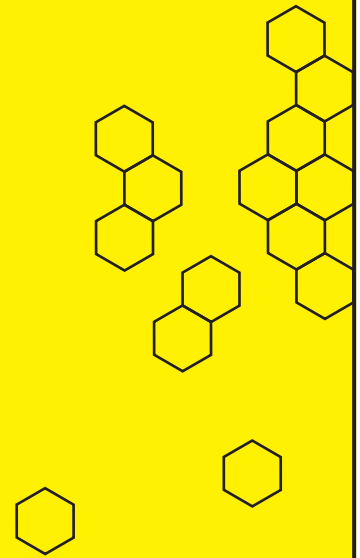

Honey Bee Manufacturing Ltd.

P.O. Box 120

Frontier SK

S0N 0W0

Tel: (306) 296-2297

Fax: (306) 296-2165

www.honeybee.ca

E-mail: info@honeybee.ca