

New Holland CR/CX Header Height Control Installation

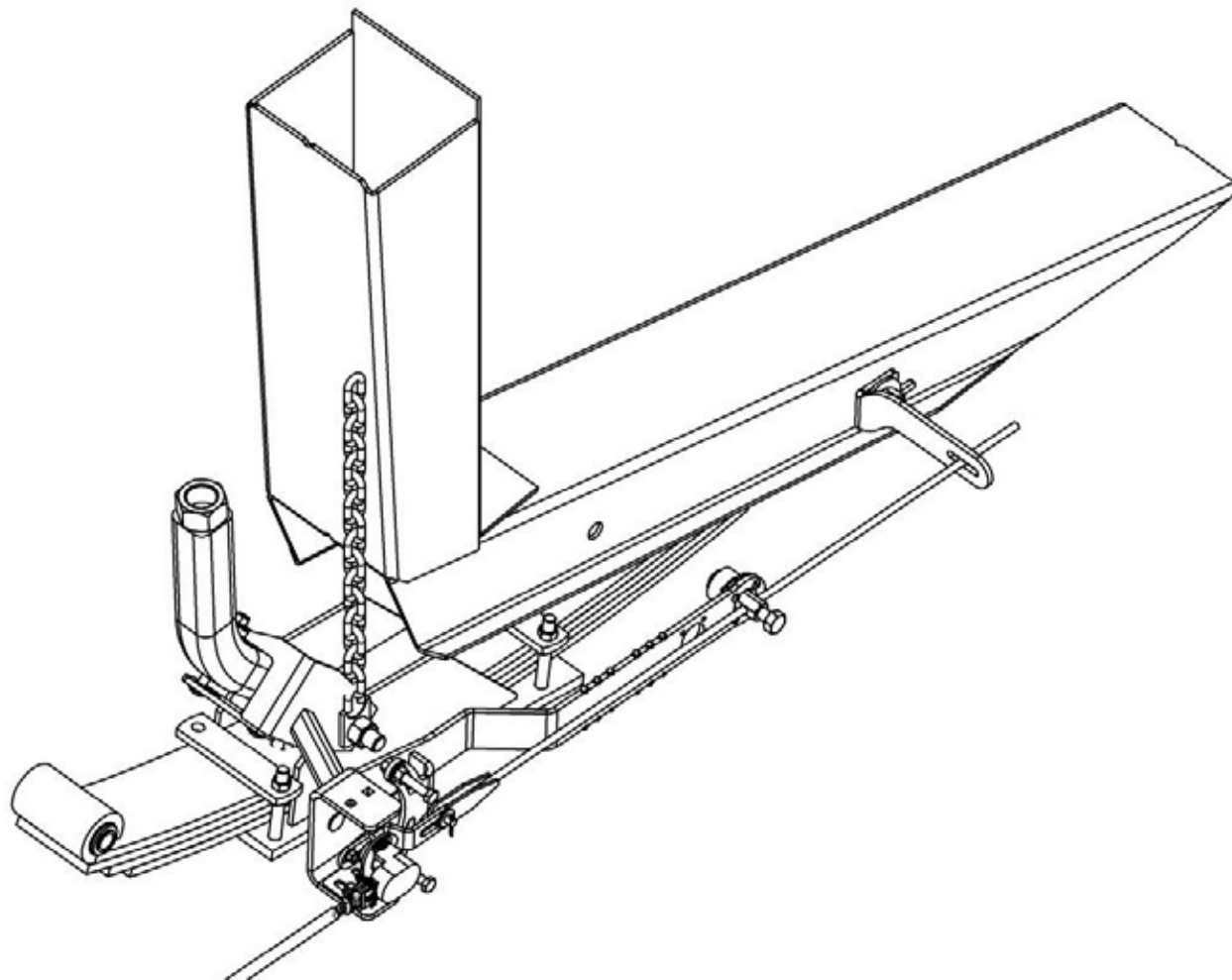

New Holland Header Height Control

Introduction

The Header Height Control system is greatly affected by the other settings on the header. For this reason, it is critical to the correct operation of the Header Height Control that it be adjusted after the header is prepared for the crop conditions that exist in your location. To achieve this, it must be set up in the shop simulating these operating parameters, or in the field under actual operating conditions. The header must be lowered into the cutting position, with the proper amount of weight on the gauge wheels and with the cutting angle set.

Since the header tilt changes the header's center of gravity and cutting angle, adjustments to the header tilt will affect the deflection of the suspension springs, which in turn will affect the calibration of the height sensor. Make sure that the cutting angle is properly set.

Refer to the Operator's Manual. Ensure the header is level, the cutter bar is at a good height for most crops, and that the mounting points, restrainer chains and lift link bolts are set correctly. When you are satisfied that the header is physically set up, study these instructions, then install and calibrate the Header Height Control.

The header height control system uses different sensors for each make of combine, therefore the sensors you see in the illustrations in this manual may not appear to be the same as those that arrived in your kit.

Terminology

The following diagram illustrates the important components and the terms used for them in this installation guide.

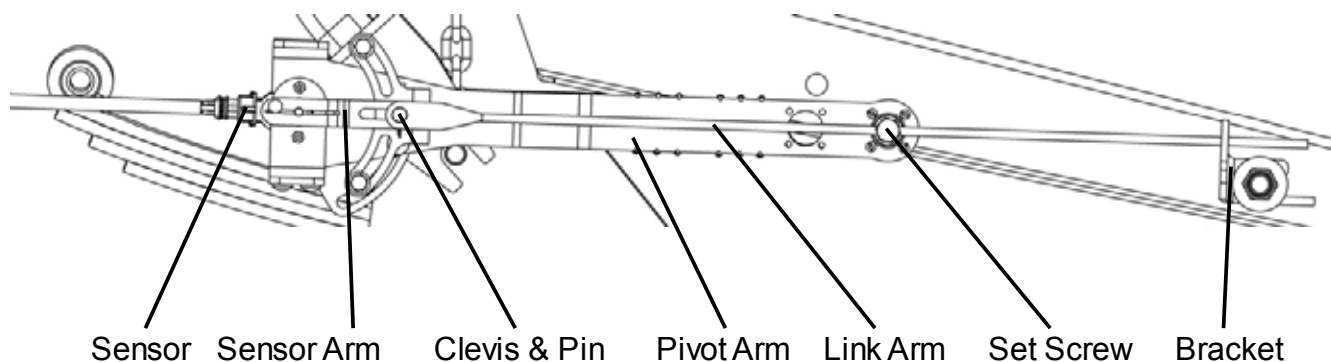

Parts List

1. Bracket - RH Sensor Rod
2. Wire Harness
3. Bracket - LH Sensor Rod
4. Sensor Link Arm
5. Sensor Mount Arm LH
6. Sensor Mount Arm RH
7. Sensor Assembly LH
8. Sensor Assembly RH

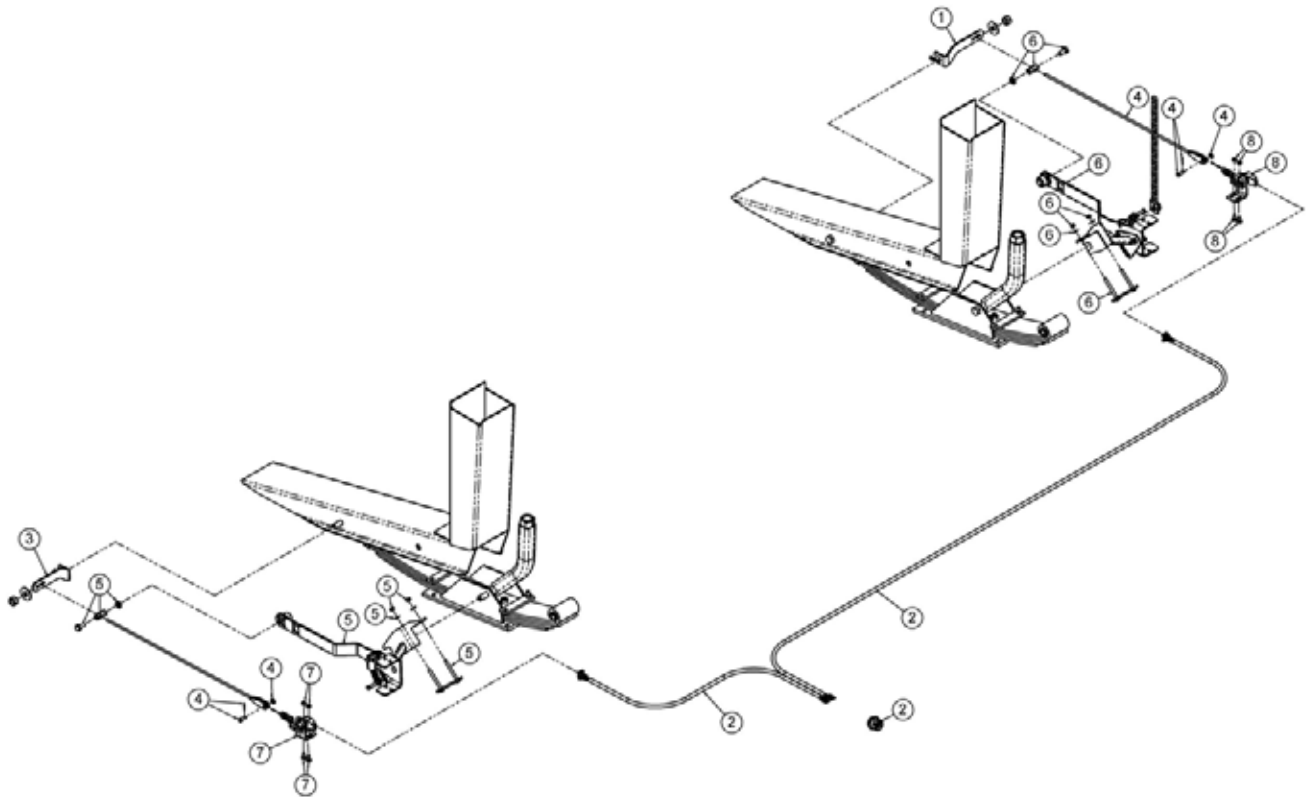

Installation

1. Attach the Mounting Brackets to the frame. Connect the two sensor mount arms to the mounting brackets. Take note of the restrainer chain location on the right hand side.

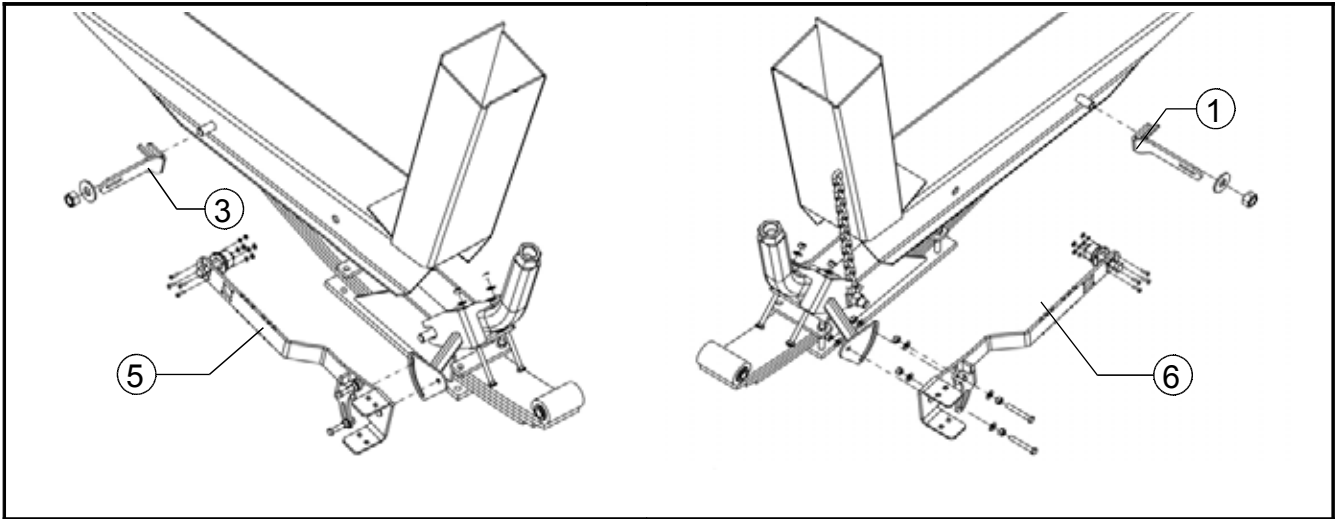

2. Connect and assemble the Link arm, sensor assembly and the wire harness.

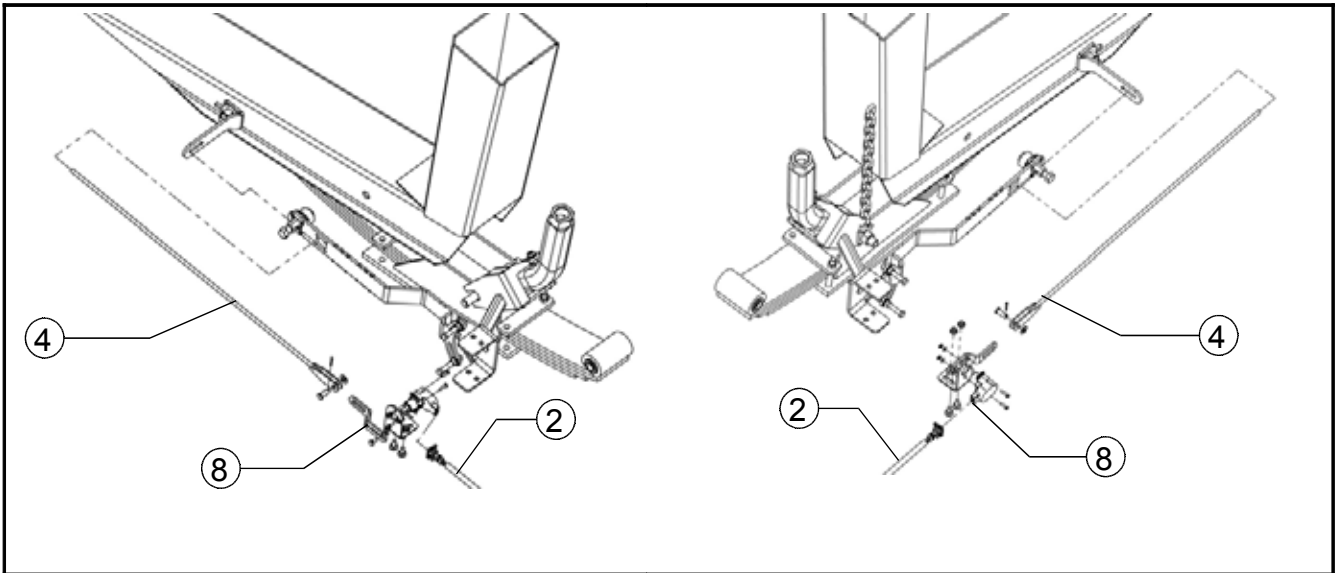

New Holland Header Height Control – Owner's Manual

1. Ensure everything is assembled as shown in the illustration below.

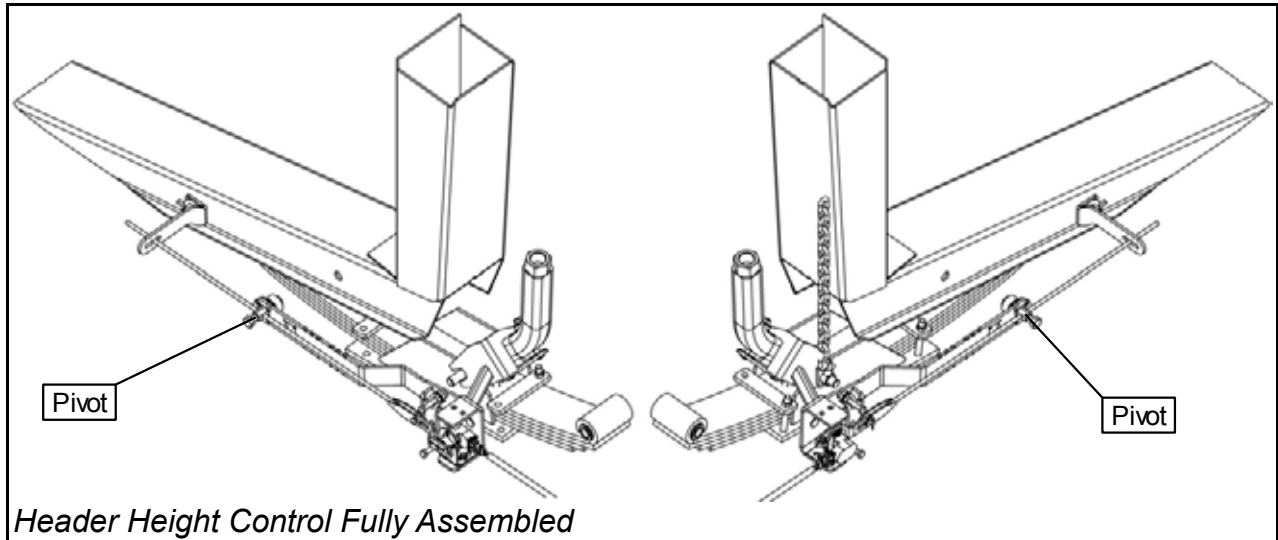

2. Check the pivot to ensure it does not bind and has adequate room for movement. If it is restricted, unscrew the pivot point and install additional ½" SAE Washers in between the coupler nut and bearing to increase the clearance.
3. Ensure the Clevis and Pin rotate freely and do not bind (*See Lower Right*). If there is not enough clearance, pry the clevis slightly apart with a screwdriver. Make sure the pin is located in the rear of the sensor arm slot (*See Below*).

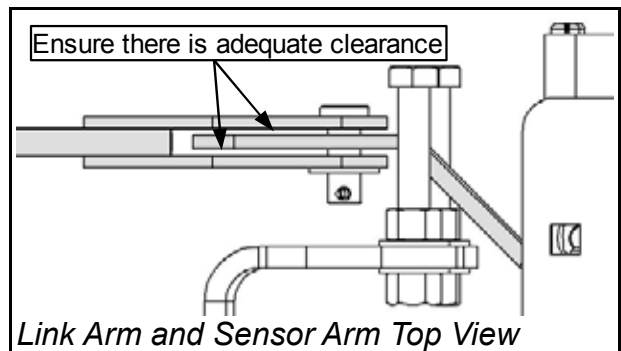
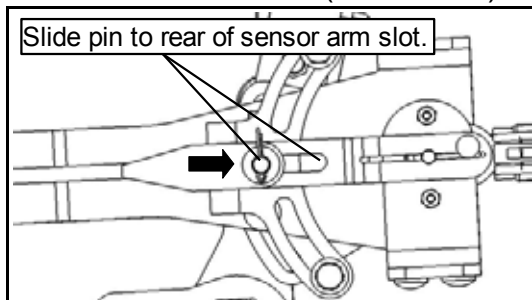
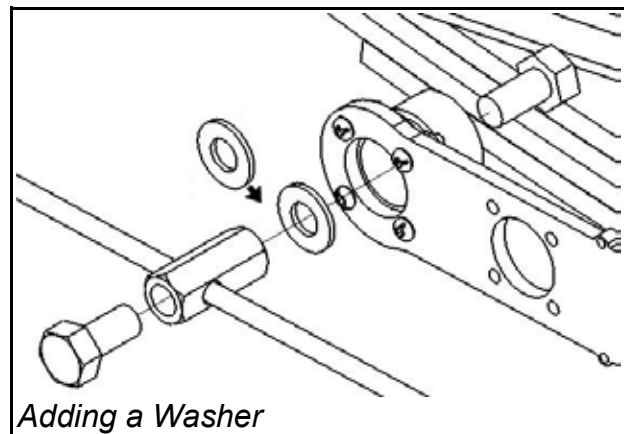

New Holland Header Height Control – Owner's Manual

3. Connect the wire harness to the 31 pin plug located on the multi coupler.

- The LH Green wire goes in hole 1.
- The LH White wire goes in hole 23.
- The LH Black wire goes in hole 25.
- The RH Green wire goes in hole 2.
- The RH White wire goes in hole 5.
- The RH Black wire goes in hole 6.

4. Run the left hand wire down to the left hand sensor and plug in. Ensure you secure the wire along the route and on the top of the sensor assembly with zip ties.

5. Run the right hand wire down through the 2x2 angle iron along the bottom of the sub frame, then secure the plug to the right hand sensor. Use zip ties to secure.

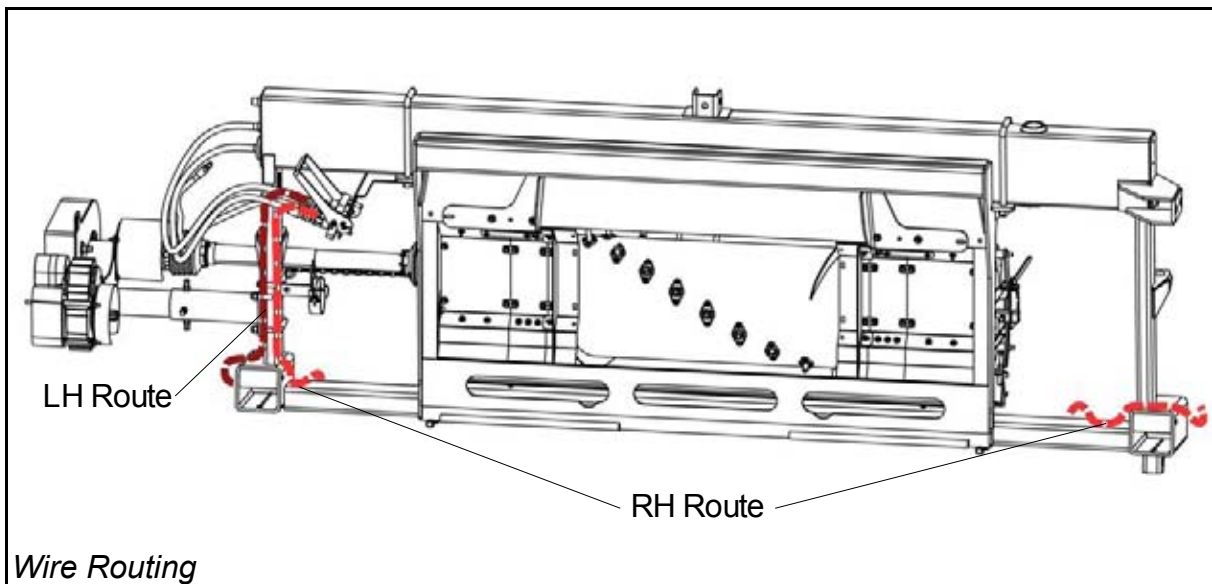
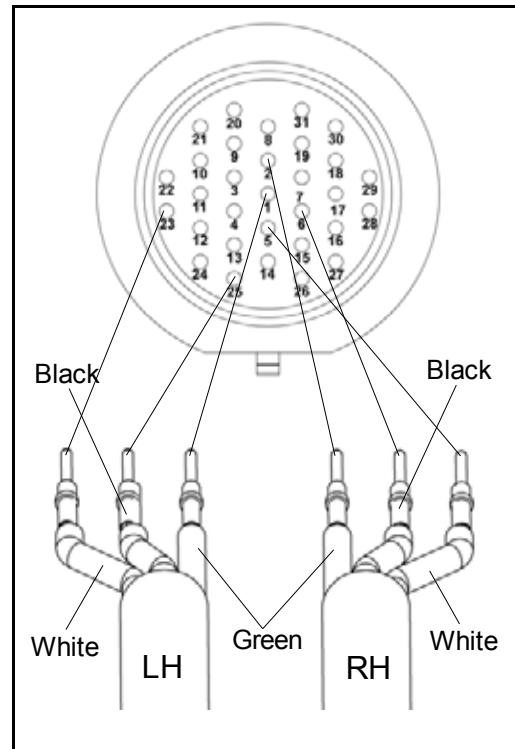

Initial Setting

1. Ensure the header is properly installed on the power unit, leveled and fully connected to all hydraulic and electrical systems.
2. Park the unit on a flat, hard surface and fully raise the header off the ground so there is no weight on the gauge wheels.
3. Ensure the restrainer chains on both sides of the sub frame have been placed in their loosest position.
4. Set the header tilt to the anticipated operating angle, using either the manual turnbuckle or the hydraulic tilt, if equipped.
5. Turn off the combine and wait for all moving parts to stop before exiting the cab.
6. Set the feeder house lift cylinder safety locks in place.
7. Check the pressure of the sensor arm against the top stop. The arm should contact the stop very lightly.
8. If the arm does not contact the top stop or it is too tight against the stop, loosen the pivot and pivot lock bolts and tilt the unit until the desired contact pressure is achieved.
9. Proceed to “Calibration” on the following page. If the calibration is successful, the unit is ready to operate. If the combine computer cannot calibrate the header, one or more voltage is outside the parameters. Continue with “Detailed Setting”.

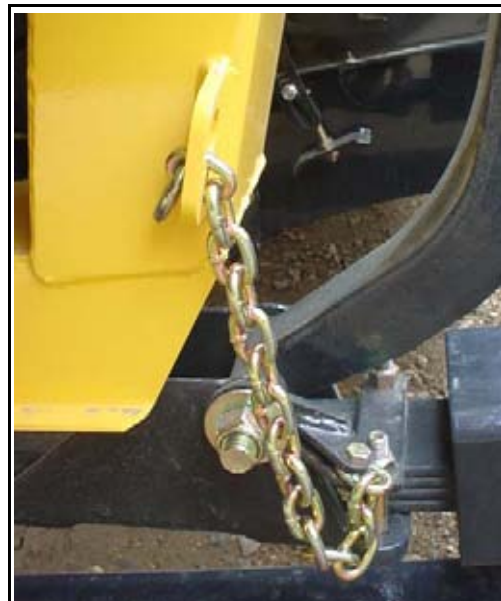

Loose Restrainer Chain

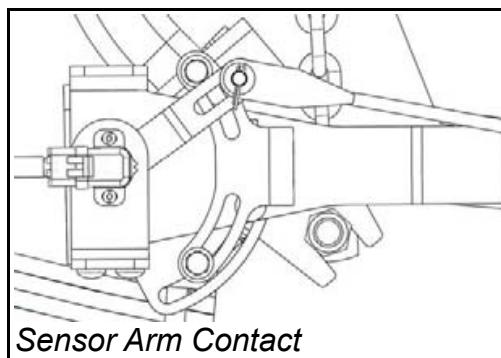

Sensor Arm Contact

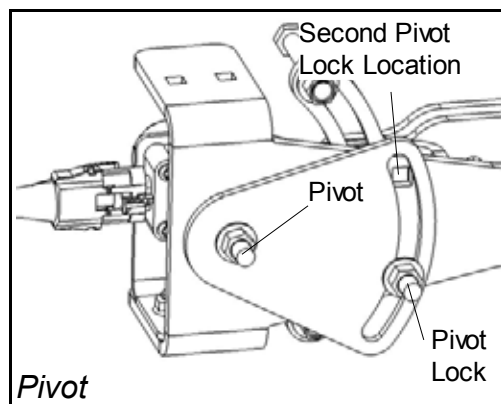

Pivot

Detailed Setting

1. To obtain the maximum range of voltage variation from the sensors, make sure that the clevis on the link arm is retracted all the way towards the back of the header. If not, loosen the set screw located at the center of the link arm, and slide the clevis portion of the link arm as far as possible to the rear, while maintaining the line of sight previously set. Secure the set screw at the center of the link arm. (*See Right*)

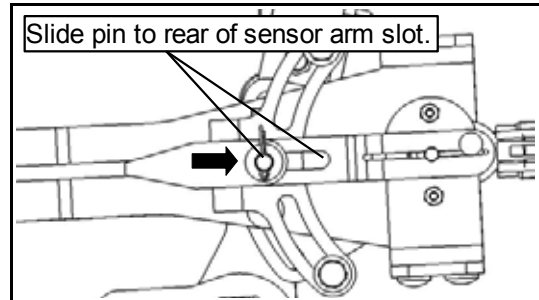

Some sensors are internally limited in their travel, and forcing them will break the sensor. These units can be identified by turning the sensor shaft and noting a slight spring-loading in one direction of travel.

If you cannot easily align the unit, check your assembly against the sensor diagrams provided in the operator's manual, and correct as needed.

2. If the sensor arm reaches the end of it's travel before contacting either the top or the bottom stops, loosen the stop bolt and move it into light contact with the arm, then re-tighten.

Calibration

1. It may be easier, depending on the height control system in the combine, to have an assistant in the cab operate the controls, monitor, and record the readings.
2. Check the multi-coupler plug connection to ensure it is fully seated.
3. Review in detail the combine instructions for the electronic controls, as they relate to diagnosis and calibration.
4. If the readings are within the specified range, (See *Table 1: Voltage Readings listed by Application*), the unit is calibrated. If not, follow the steps on the previous page under “Detailed Settings”

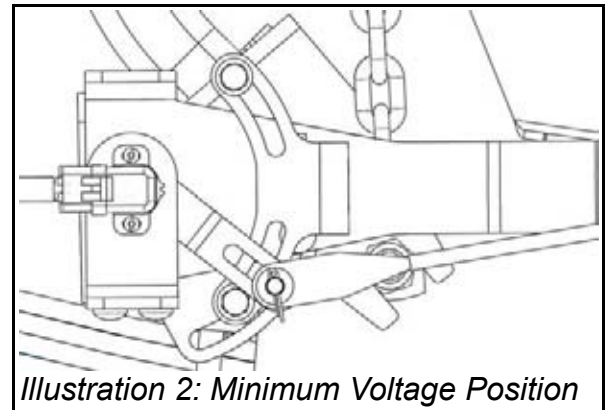
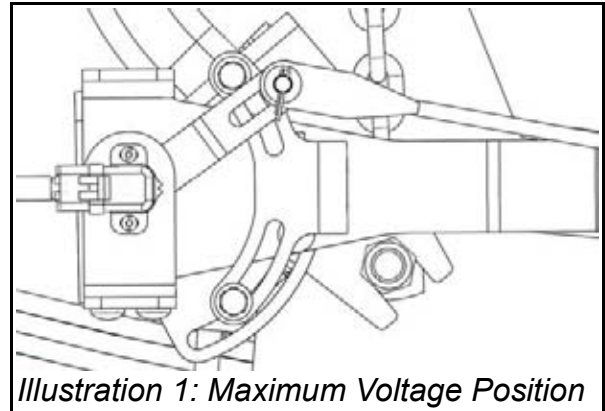

	High Reading Not above:	Low Reading Not Below:	Maximum Difference:	Minimum Difference:
2008 New Holland CR 9040/9060	4.5 Volts	0.5 Volts	4.5 Volts	1.5 Volts
New Holland CR/CX	7.5 Volts	2.5 Volts	5.0 Volts	2.5 Volts
AFX 7010/8010	4.5 Volts	0.5 Volts	4.0 Volts	2.5 Volts
John Deere 50/60	4.5 Volts	0.5 Volts	4.0 Volts	2.5 Volts
CAT Lexion 400/500	4.5 Volts	0.5 Volts	4.0 Volts	2.5 Volts
Challenger 660/670	4.5 Volts	0.5 Volts	4.0 Volts	2.5 Volts
MF-9690/9790	4.5 Volts	0.5 Volts	4.0 Volts	2.5 Volts
Gleaner R 65/R75	4.5 Volts	0.5 Volts	4.0 Volts	2.5 Volts
AGCO w/ Multi Coupler	3.8 Volts	1.5 Volts	2.3 Volts	1.5 Volts

Table 1: Voltage Readings Listed by Application



Some combines do not have a header height sensor voltage reading on the display in the cab. In this situation, a combine diagnostic computer will be required. Please consult your dealer for additional voltage information.

Fault Diagnosis

- If the upper position voltage reading is above the maximum, (or you receive an upper limit error code), you can decrease the upper voltage reading by using the following steps:
 - Lift the sensor arm until it comes into contact with the top stop bolt.
 - Loosen the Screws holding the sensor in place.
 - While facing the rear side of the sensor, slightly rotate the sensor counter-clockwise until the desired voltage is achieved.
 - Re-tighten the sensor screws.
 - If this adjustment makes the lower position voltage too low, loosen the bottom stop bolt and raise it up until the low position voltage reaches the desired value.
- If the lower position voltage is too low, (or you receive a low limit error code), you can increase the lower voltage reading by using the following steps:
 - Lower the sensor arm until it comes into contact with the bottom stop bolt.
 - Loosen the Screws holding the sensor in place.
 - While facing the rear side of the sensor, slightly rotate the sensor lockwise until the desired voltage is achieved.
 - Re-tighten the sensor screws.
 - If this adjustment makes the upper position voltage too high, loosen the top stop bolt and lower it up until the upper position voltage reaches the desired value.
- If the difference between “High” and “Low” voltages is too small, a restriction in movement of the suspension, or a problem with the clevis pin location is indicated. Look for any restriction, such as restrainer chains caught or hooked too short, and ensure the clevis is set fully to the back of the sensor bracket, with the line of sight as close to straight as possible.

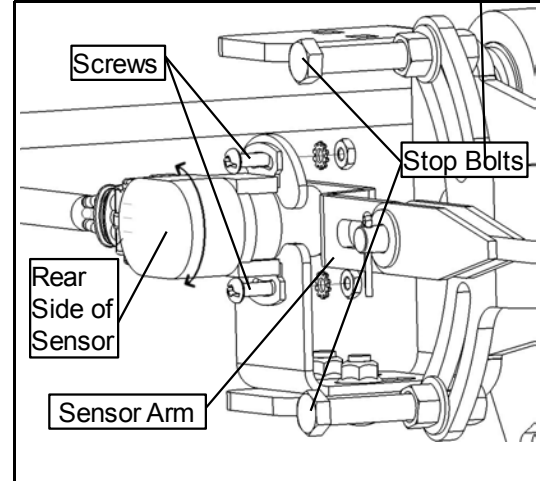

New Holland Header Height Control – Owner's Manual

- For some conditions/combines, it may be necessary to install the set screw in the rear hole of the pivot arm in order to decrease the sensitivity of the sensor, thus lowering the range of voltages available.

