

Honey Bee

CAT Combine Hydraulic Reservoir Integration Instructions

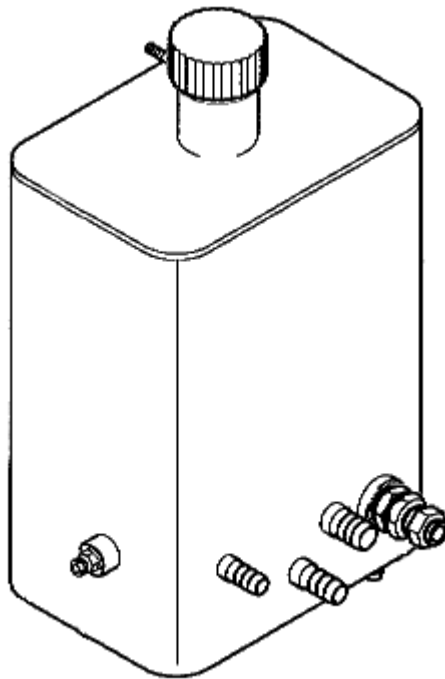

CAT Grain Belt Plus - Combine Reservoir Integration

Parts List		
ITEM NO.	QTY	DESCRIPTION
1	1	Q/CPLR 3/4 M PKR-FPT
2	1	Q/CPLR 3/4 M DUST CAP
3	2	ADAPTOR 12MJ 22MM STD PIPE
4	2	TEE SW. L22-MM30-MM30
5	1	HH12 336 12MP -12FJX FRMX
6	1	HH12 222 8MP -12FJX FRMX
7	1	Q/CPLR 1/2 F
8	1	Q/CPLR 1/2 F DUST CAP

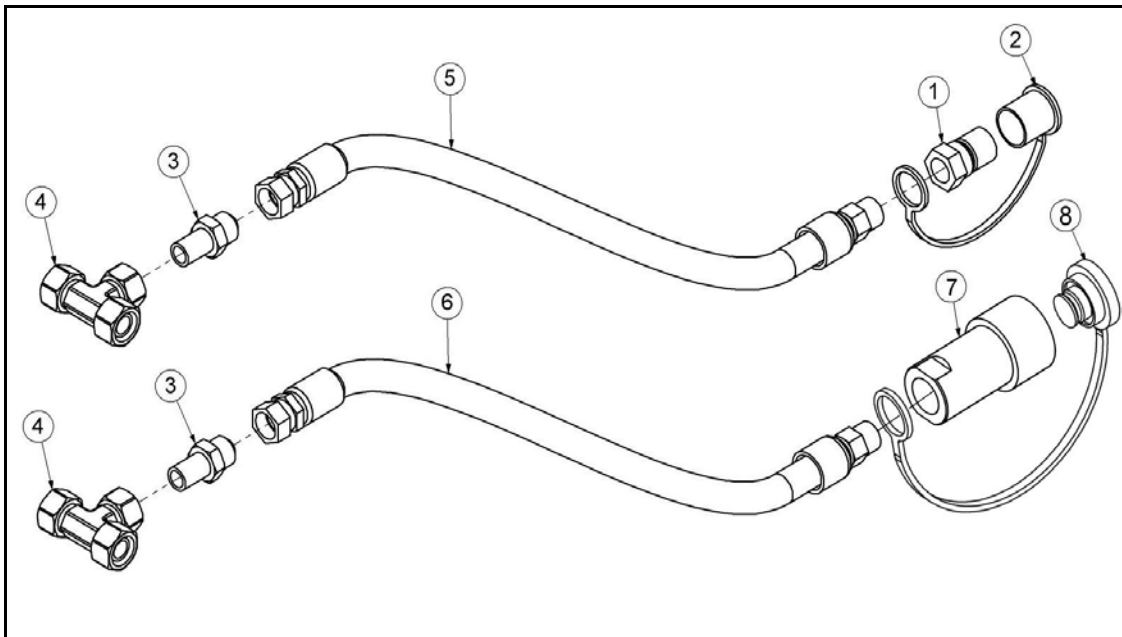

Preparation

Check the contents of the kit to ensure you have received all the correct parts, and everything is in good condition.

In this procedure, All the hydraulic fluid needs to be drained from the combines reservoir. This is a large volume of oil, in order to keep as much of it in the system as possible, fully extend all hydraulic cylinders so that they each act as a small reservoir. Tilt the table forward, open the trap door under the finger auger. Fully raise and extend the reel, secure the locks on the reel lift cylinders to prevent the reel from falling. Lift the table off the ground, lock in place, and extend the combine auger.

Familiarize yourself with the parts and these instructions before starting work on the installation.

 **IMPORTANT** Use teflon tape on the quick coupler fitting to ensure a good seal.

 **DANGER** Be sure to turn off the combine and wait for all moving parts to come to a complete stop before exiting the cab.

 **DANGER** When checking a pressurized hydraulic system for leaks, do not use your bare hands, use a piece of cardboard as high pressure hydraulic fluid can penetrate your skin.

Directions

For the purposes of this manual, front refers to the cutter bar portion of the header, rear refers to the combine mount side, and left and right are as seen when standing at the rear facing the front.

1. Disconnect the indicated brass line from the main valve assembly and from the hose clamp as shown.

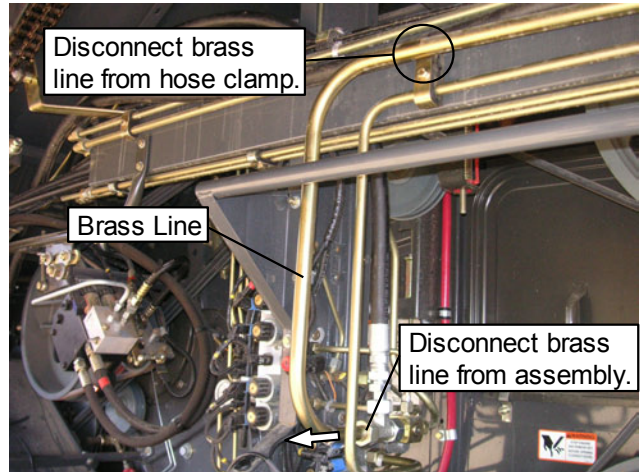

2. Secure one of the provided tees to the fitting from which you had disconnected the brass line. Secure the adapter to the middle fitting of the tee. Remove the cap from the side of the tee and connect the brass line to the assembly.

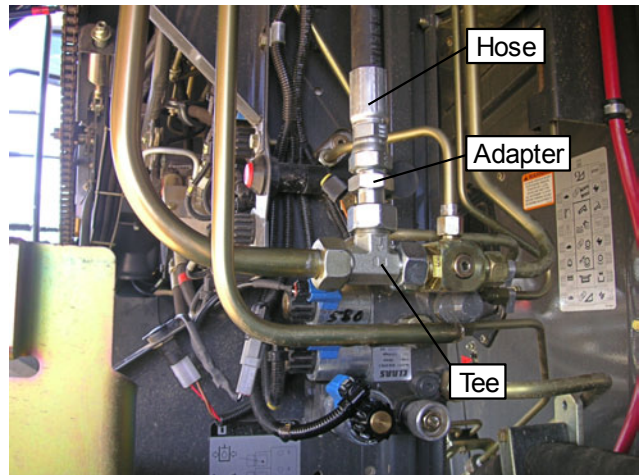
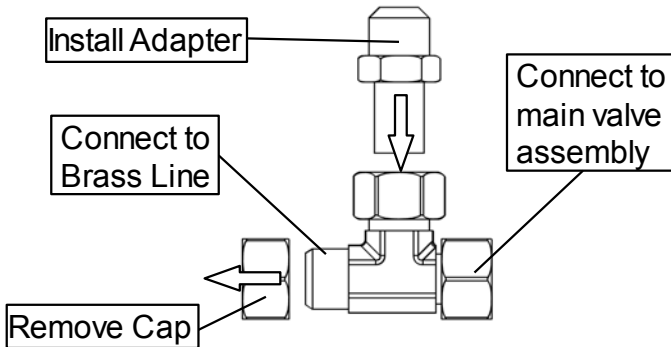

3. Secure the HH12 222 8MP -12FJX hose (#6) to the adapter on the tee.

4. Run the hose up along the path indicated to the right, and out underneath the front of the walkway to the cab.

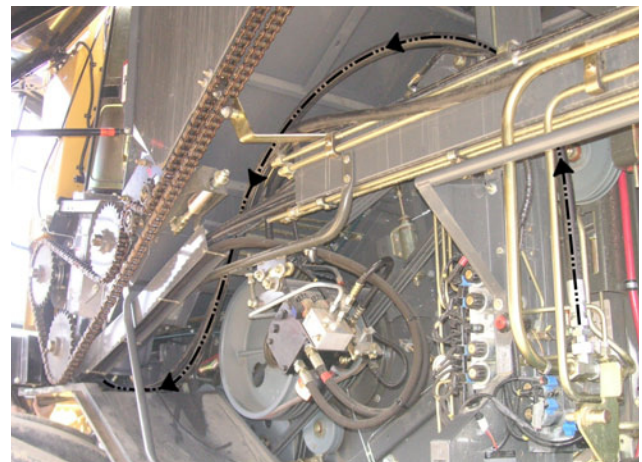
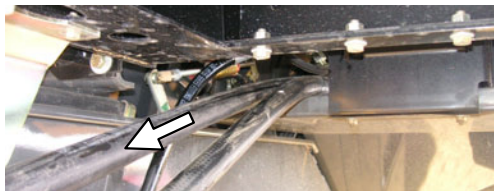

5. Wrap the remaining end of the HH12 222" 8MP -12FJX hose (#6) with teflon tape and secure the female quick coupler to the hose.

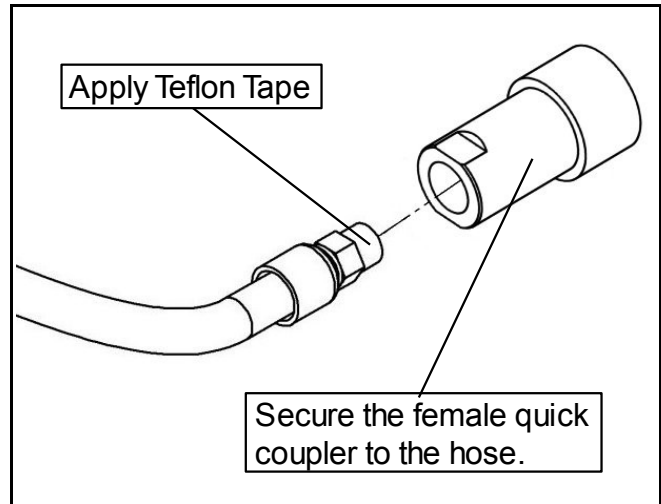

6. Secure the hose with the female quick coupler to the pump supply line on the hydraulic pump on the header. The pump supply line comes from the hydraulic oil filter on the pump assembly.

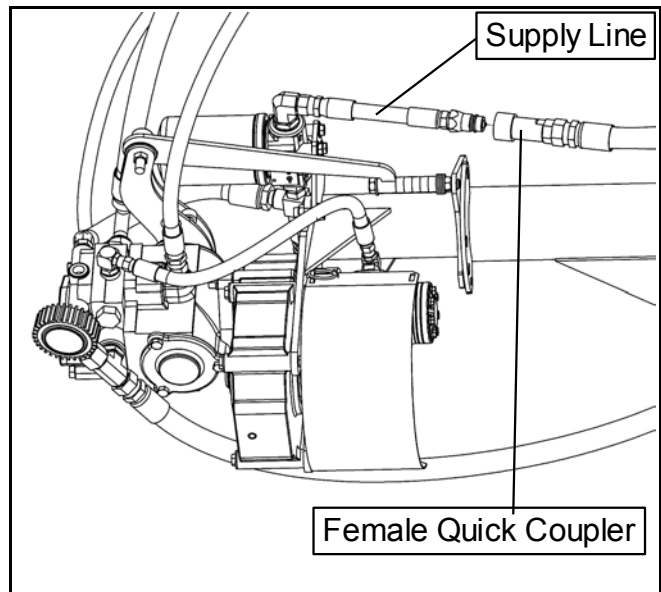

7. Remove the hose from the return port on the combine hydraulic reservoir.

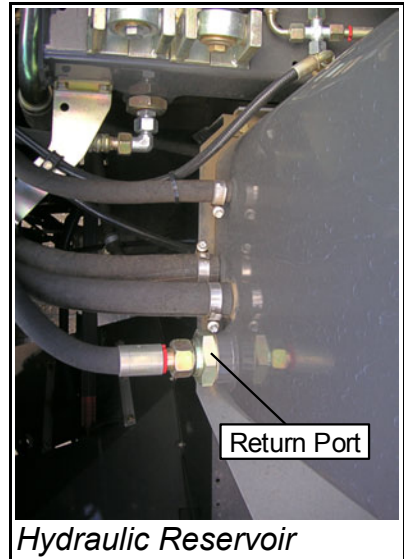
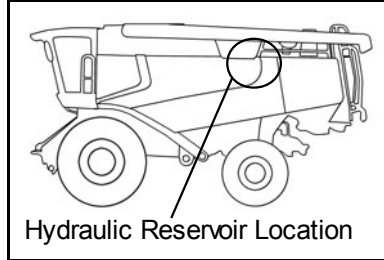

8. Install the tee fitting into the return port on the hydraulic reservoir.

9. Remove the cap from the tee fitting and connect the original hose to the end of the tee.

10. Attach the adapter fitting to the offshoot of the tee.

11. Connect the provided hydraulic hose to the adapter fitting.

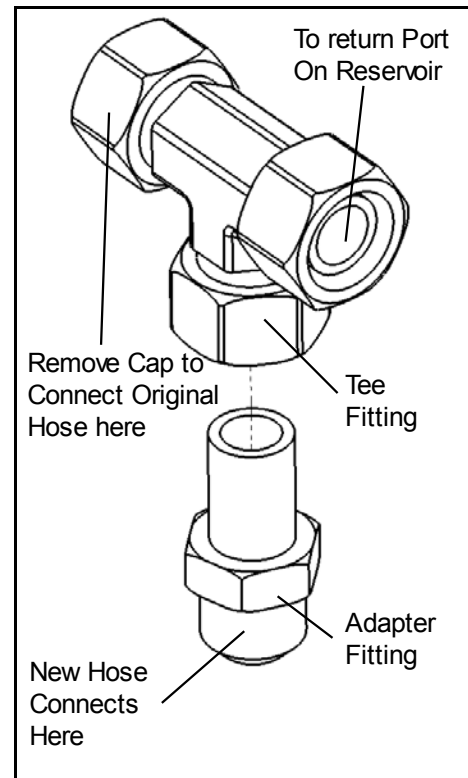

12. Run the hose along the same route as the hose that you installed in a previous step. Continue to the front of the combine, securing with zip-ties along the way. Do not route the hose along any location where it may become damaged through contact with moving parts.

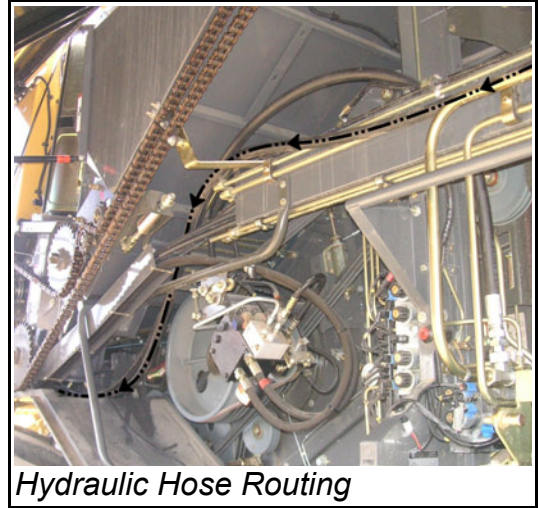
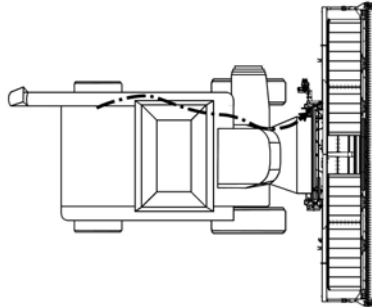

Hydraulic Hose Routing

13. Slide the base of the end cap over the hose. Wrap the end of the hose with teflon tape and screw on the quick coupler fitting.

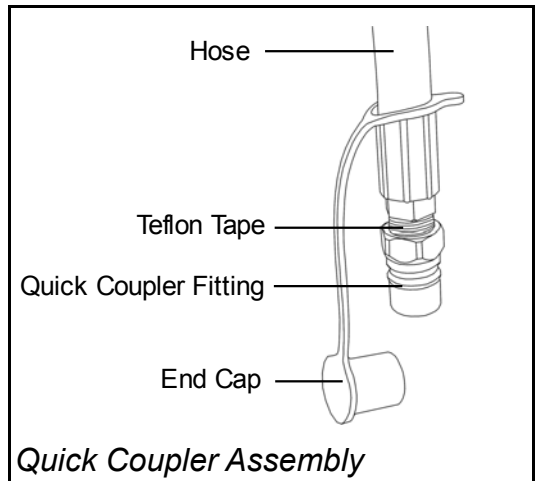

Quick Coupler Assembly

14. The hose plugs into the quick coupler located at the upper left corner of the sub frame.



Ensure that the quick coupler connection is secure. Failure in this connection will result in damage to your equipment.

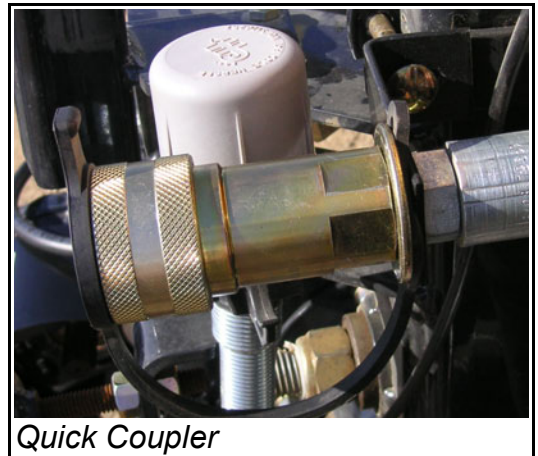

Quick Coupler

15. Check all new hydraulic connections for leaks.



Ensure that all hydraulic connections are secure. Failure in the hydraulic system can lead to equipment damage or injury.

16. Test your table to ensure everything is working correctly.

