

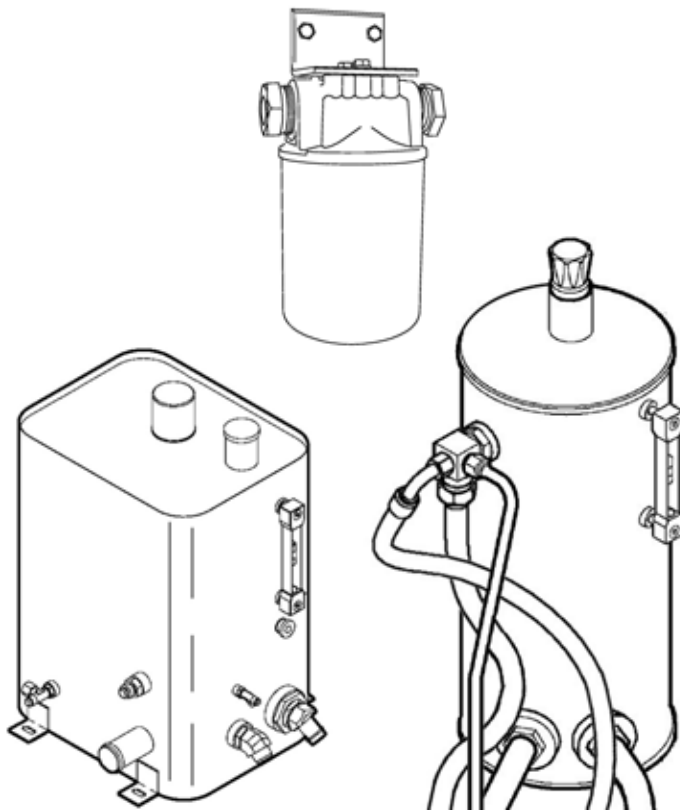

AGCO
Combine Hydraulic Reservoir Integration
Instructions



AGCO Grain Belt Plus Combine Reservoir Integration

Parts List			
ITEM NO.	QTY	DESCRIPTION	PART NO.
1	1	TEE SW. 12MJ -12FJX-12MJ	21279
2	1	NIPPLE 12MJ - 12MP	21303
3	1	TEE SW. 16MJ -16MJ -16FJX	21330
4	1	TEE 12FP-12FP-12MP	26095
5	1	Q/CPLR 3/4 M PKR-FPT	26354
6	1	Q/CPLR 3/4 M DUST CAP	26593
7	1	HH12 336 12MP -12FJX FRMX	81096
8	1	ADAPTER 12MJ - 16FJ	25847

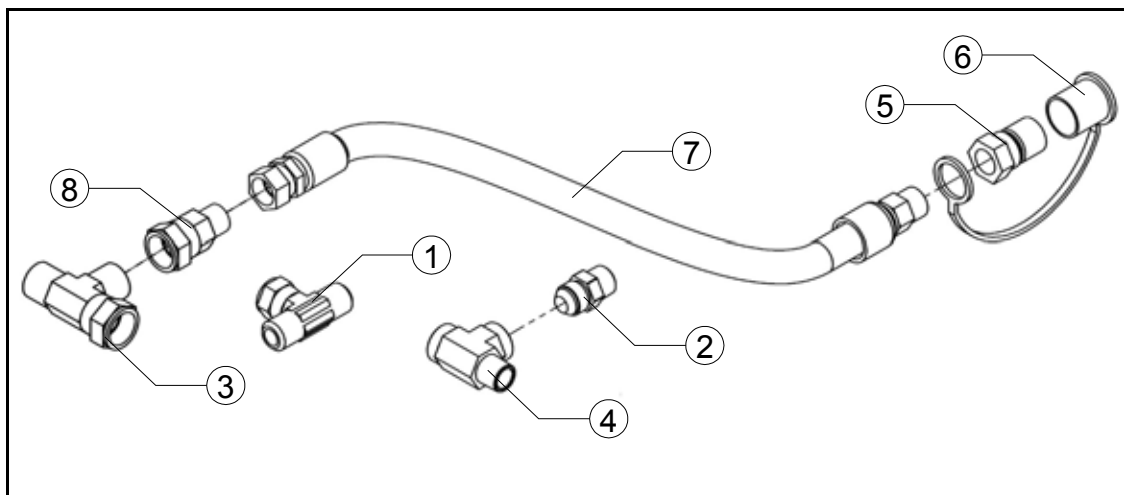

Use 12MJ-12FJX-12MJ (#1)
For:
- Massey 9790/9690
- Challenger 670/660
- Gleaner A75/A65

Use 12MJ-12MJ-12FJX (#3)
For:
- Massey 9895
- Challenger 680B
- Gleaner A85

Use 12MP-12MJ (#2) And
12MP-12FP-12FP (#4) For:
- Gleaner 'R' Series

Preparation

For the purposes of this manual, front refers to the cutter bar portion of the header, rear refers to the combine mount side, and left and right are as seen when standing at the rear facing the front.

Check the contents of the kit to ensure you have received all the correct parts, and everything is in good condition.

In this procedure, All the hydraulic fluid needs to be drained from the combines reservoir. This is a large volume of oil, in order to keep as much of it in the system as possible, fully extend all hydraulic cylinders so that they each act as a small reservoir. Tilt the table forward, open the trap door under the finger auger. Fully raise and extend the reel, secure the locks on the reel lift cylinders to prevent the reel from falling. Lift the table off the ground, lock in place, and extend the combine auger.

Familiarize yourself with the parts and these instructions before starting work on the installation.

 **IMPORTANT** Use teflon tape on the quick coupler fitting to ensure a good seal.

 **DANGER** Be sure to turn off the combine and wait for all moving parts to come to a complete stop before exiting the cab.

Before You Begin

Determine which make and model of combine you are using. If you are using a Gleaner “R” series combine, you will be required to drain all the hydraulic oil from the system as you will be connecting to the hydraulic oil filter.

All other makes and models of combine will be hooking directly up to the hydraulic reservoir. In this case you will only be required to drain enough oil to drop the level in the hydraulic reservoir down below that of the return port.

See your combine operator's manual for details on draining the hydraulic system.

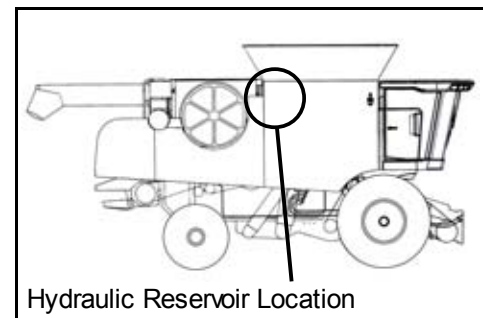

 **IMPORTANT** Each section (**A.** **B.** & **C.**) of these instructions is intended for a specific make and model of AGCO combine. Please pay careful attention and only follow the directions in the section intended for you and your machine.

A. For all Gleaner 'R' Series Combines.

- a. Remove the hose from the return port on the combine hydraulic oil filter.

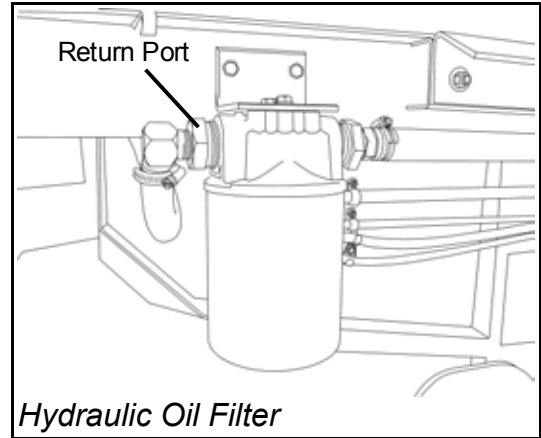
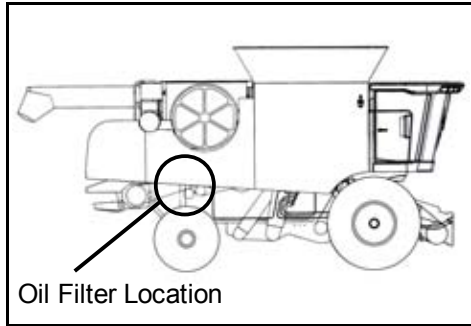

- b. Install the tee fitting into the return port on the oil filter.
- c. Attach the adapter fitting to the branch on the tee fitting.
- d. Connect the original hose to one end of the tee.
- e. Connect the provided hydraulic hose to the tee fitting.

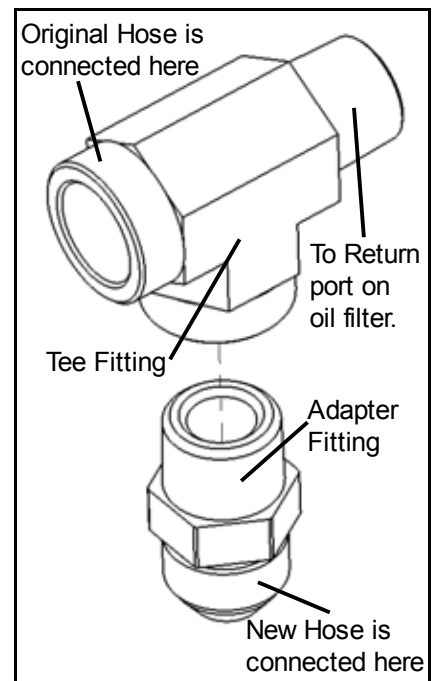

B. MF 9790 & 9690, Challenger 660 & 670, Gleaner A65 & A75.

- a. Remove the hose from the return port on the combine hydraulic reservoir.

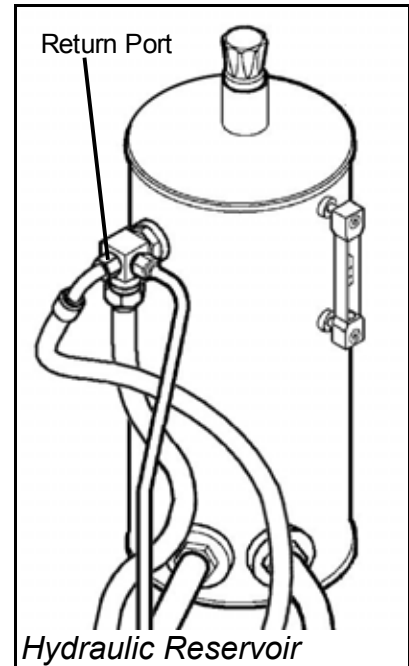

- b. Install the branch of the tee fitting into the return port on the hydraulic reservoir.

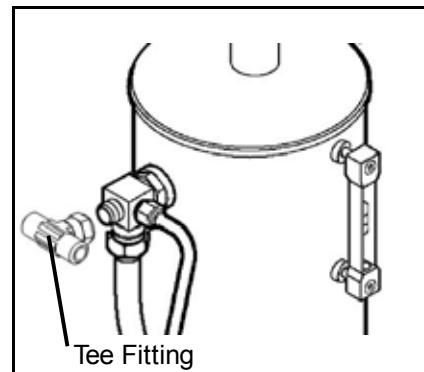

- c. Connect the original hose to one end of the tee.

- d. Connect the provided hydraulic hose to the other end of the tee fitting.

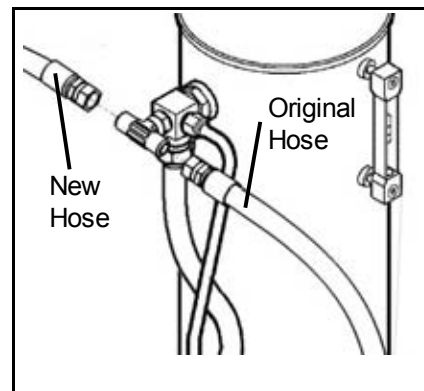

C. MF 9895, Challenger 680B, and A85 Gleaner

- a. Remove the hose from the return port on the combine hydraulic reservoir.

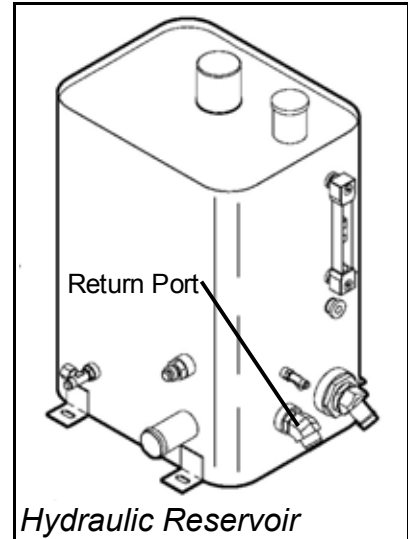

- b. Install the tee fitting onto the return port on the hydraulic reservoir.

- c. Connect the original hose to the end of the tee.

- d. Secure the indicated adapter fitting to the tee.

- e. Connect the provided hydraulic hose to the adapter.

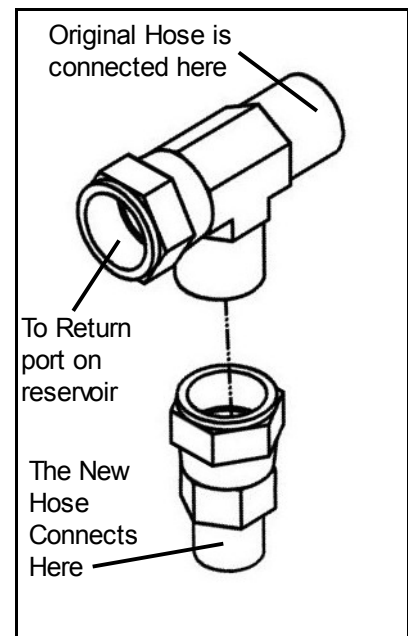

Completing the Installation (Common for all Makes)

1. Run the new hose along the existing hydraulic lines. Continue to the front of the combine, securing with zip-ties along the way. Do not route the hose along any location where it may become damaged through contact with moving parts.

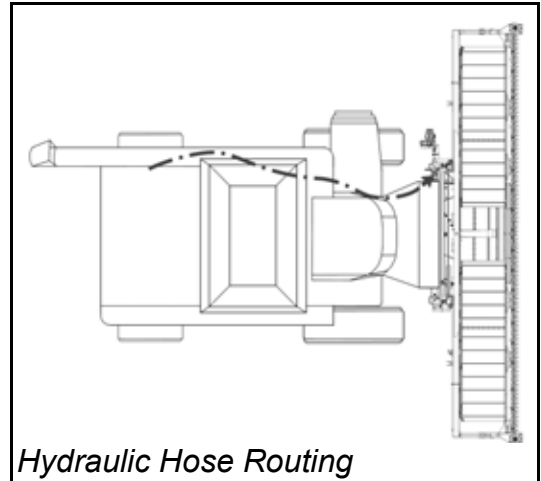

2. Slide the base of the end cap over the hose. Wrap the threads on the end of the hose with teflon tape and screw on the male quick coupler fitting.

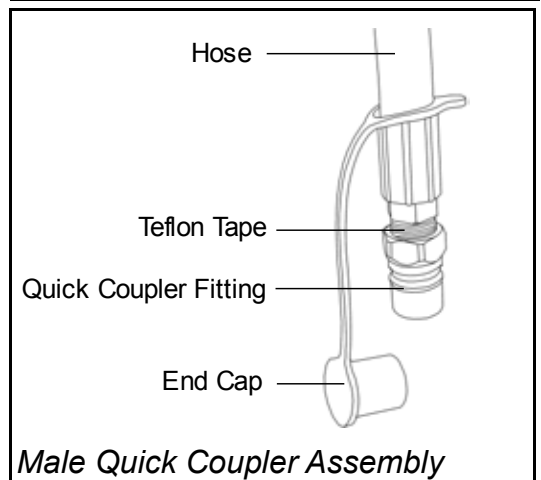

3. The hose plugs into the female quick coupler located at the upper left corner of the sub frame.



Ensure that the quick coupler connection is secure. Failure in this connection will result in damage to your equipment.

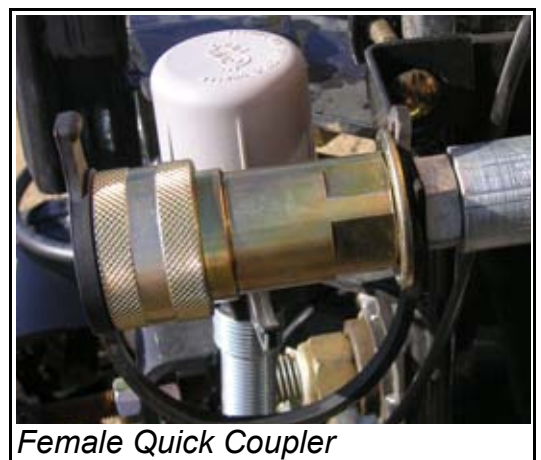

4. Refill the hydraulic reservoir as described in your combine operator's manual.
5. Check all new hydraulic connections for leaks.



Ensure the reel return quick coupler is securely connected to the hydraulic pump. Failure in this connection will also result in damage to your equipment.

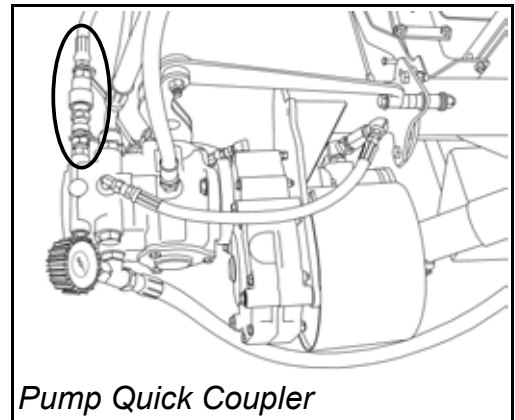

6. Test your table to ensure everything is working correctly.



If any problems arise during testing, immediately shut the combine down and rectify the issue prior to restarting.